

TopGear BLOC

INTERNAL GEAR PUMPS

A.0500.751 – IM-TG BLOC/01.01 EN (11/2021)

ORIGINAL INSTRUCTIONS

READ AND UNDERSTAND THIS MANUAL PRIOR TO OPERATING OR SERVICING THIS PRODUCT.

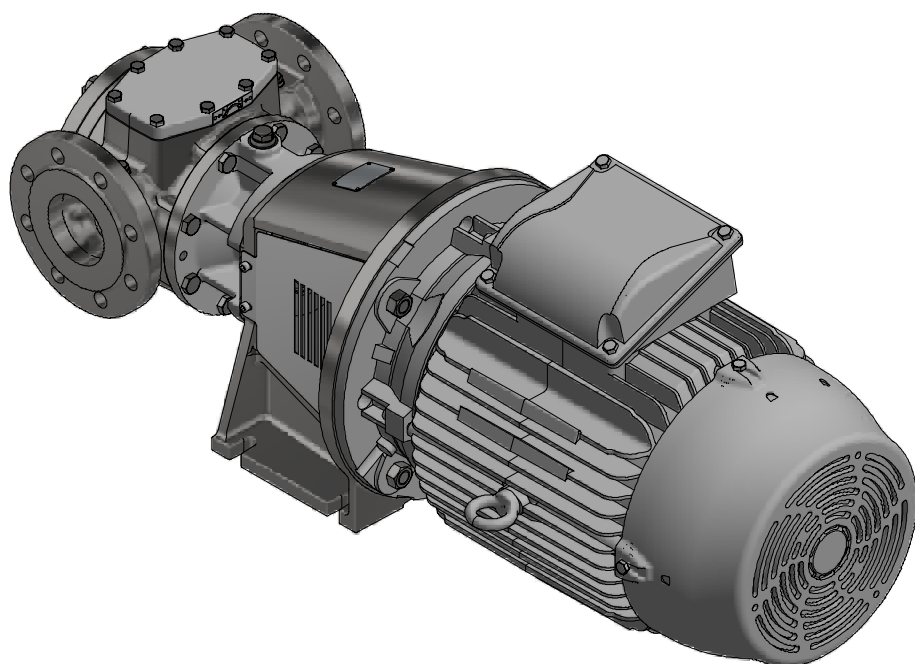
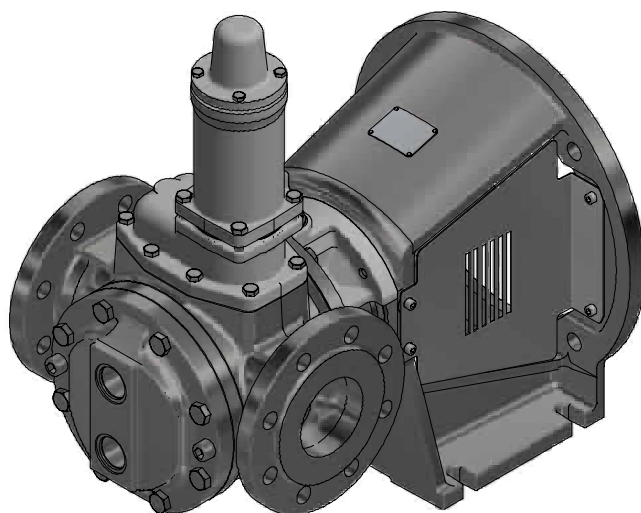
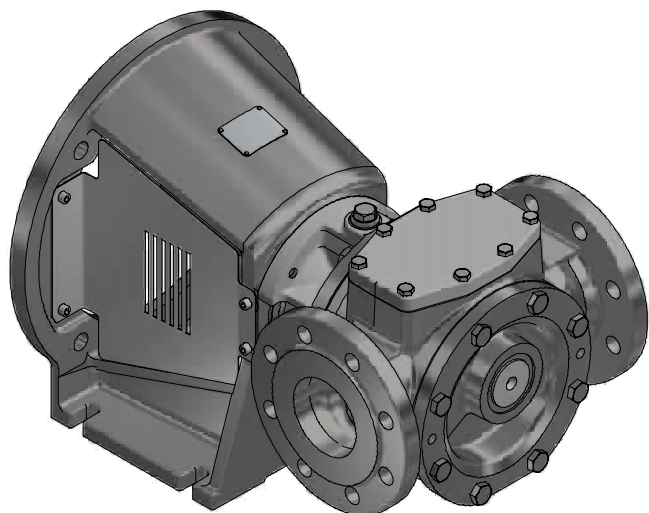

CE
UK
CA
EAC

EC-Declaration of conformity

Machinery Directive 2006/42/EC, Annex IIA

Manufacturer

SPX Flow Europe Limited Belgium
Evenbroekveld 2-6
BE-9420 Erpe-Mere
Belgium

Herewith we declare that

TopGear BLOC range Gear Pumps

Types: TG BLOC15-50
TG BLOC23-65
TG BLOC58-80
TG BLOC86-100

whether delivered without drive or delivered as an assembly with drive,
are in conformity with the relevant provisions of the Machinery Directive
2006/42/EC, Annex I.

Manufacturer Declaration

Machinery Directive 2006/42/EC, Annex IIB

The partly completed pump (Back-Pull-Out unit), member of the product
family TopGear BLOC range gear pumps, is meant to be incorporated
into the specified pump (unit) and may only be put into use after the
complete machine, of which the pump under consideration forms part,
has been declared to comply with the provisions of the Directive.

Erpe-Mere, 01 January 2021



Frank Vander Beken
Branch Manager

Contents

1.0	Introduction	7
1.1	General.....	7
1.2	Reception, handling and storage	7
1.2.1	Reception	7
1.2.2	Handling.....	7
1.2.3	Storage	7
1.3	Safety.....	8
1.3.1	General	8
1.3.2	Pump units	9
1.3.2.1	Pump unit handling.....	9
1.3.2.2	Installation.....	9
1.3.2.3	Before commissioning the pump unit.....	10
1.3.2.4	Name plate – CE Declaration of Conformity.....	10
1.4	Technical conventions.....	11
2.0	Pump description	12
2.1	Type designation	12
3.0	General technical information.....	14
3.1	Pump standard parts.....	14
3.2	Operating principle.....	14
3.2.1	Self-priming operation.....	15
3.2.2	Safety relief valve – Working principle	15
3.3	Sound	15
3.4	General performance	15
3.5	Main characteristics	16
3.6	Pressure	17
3.7	Sound level	17
3.7.1	Sound level of a pump without drive.....	17
3.7.2	The sound level of the pump unit.....	18
3.7.3	Influences	18
3.8	Material options	18
3.9	Jacket options	18
3.10	Internals.....	19
3.10.1	Bush materials.....	19
3.10.2	Maximum temperature of internals.....	19
3.10.3	Operation under hydrodynamic lubrication conditions	19
3.10.4	Maximum torque of pump shaft and rotor material combination.....	19
3.11	Mass moment of inertia.....	20
3.12	Radial clearances.....	20
3.13	Play between gear teeth.....	20
3.14	Maximum size of solid particles	20
3.15	Shaft sealing.....	20
3.16	Safety relief valve	21
3.16.1	Pressure.....	22
3.16.2	Heating.....	22
3.16.3	Safety relief valve – Relative adjustment.....	22

3.16.4	Sectional drawings and part lists.....	24
3.16.4.1	Single safety relief valve	24
3.16.4.2	Heated spring casing.....	25
3.16.4.3	Double safety relief valve.....	25
3.17	Installation.....	26
3.17.1	General	26
3.17.2	Location	26
3.17.2.1	Short suction line	26
3.17.2.2	Accessibility	26
3.17.2.3	Outdoor installation	26
3.17.2.4	Indoor installation	27
3.17.2.5	Stability.....	27
3.17.3	Drives.....	27
3.17.3.1	Starting torque.....	27
3.17.4	Shaft rotation for pump without safety relief valve	28
3.17.5	Shaft rotation for pump with safety relief valve.....	29
3.17.6	Suction and discharge pipes	30
3.17.6.1	Forces and moments.....	30
3.17.6.2	Piping.....	30
3.17.6.3	Isolating valves.....	31
3.17.6.4	Strainer.....	31
3.17.7	Secondary piping.....	31
3.17.7.1	Drain lines	31
3.17.7.2	Heating jackets	32
3.17.8	Flush media.....	32
3.17.9	Guidelines for assembly.....	33
3.17.9.1	Transport of pump unit.....	33
3.17.9.2	Foundation pump unit	33
3.17.9.3	Variators, Motors	33
3.17.9.4	Electric motor drive.....	33
3.18	Instructions for start-up	35
3.18.1	General	35
3.18.2	Cleaning the pump.....	35
3.18.2.1	Cleaning suction line.....	35
3.18.3	Venting and filling.....	35
3.18.4	Checklist – Initial start-up	36
3.18.5	Start-up.....	37
3.18.6	Shut-down.....	37
3.18.7	Abnormal operation	37
3.19	Trouble shooting.....	38
3.19.1	Instructions for re-using and disposal	40
3.19.1.1	Re-use	40
3.19.1.2	Disposal	40
3.20	Maintenance instructions	41
3.20.1	General	41
3.20.2	Preparation.....	41
3.20.2.1	Surroundings (on site)	41
3.20.2.2	Tools.....	41
3.20.2.3	Shut-down.....	41
3.20.2.4	Motor safety	41
3.20.2.5	Conservation.....	41
3.20.2.6	External cleaning	42
3.20.2.7	Electrical installation.....	42
3.20.2.8	Draining of fluid	42

	3.20.2.9 Fluid circuits.....	42
	3.20.3 Specific components.....	43
	3.20.3.1 Nuts and bolts	43
	3.20.3.2 Plastic or rubber components.....	43
	3.20.3.3 Flat gaskets	43
	3.20.3.4 Filter or suction strainer.....	43
	3.20.3.5 Anti-friction bearings.....	43
	3.20.3.6 Sleeve bearings.....	43
	3.20.3.7 Shaft seal – Mechanical seal	43
	3.20.4 Front pull-out	44
	3.20.5 Back pull-out.....	44
	3.20.6 Clearance adjustment	44
	3.20.7 Designation of threaded connections.....	45
	3.20.7.1 Threaded connection Rp (example Rp 1/2).....	45
	3.20.7.2 Threaded connection G (example G 1/2).....	45
4.0	Instructions for assembly and disassembly.....	46
4.1	General.....	46
4.2	Tools.....	46
4.3	Preparation	46
4.4	After disassembly.....	46
4.5	Coupling bush	47
	4.5.1 General	47
	4.5.2 TG BLOC15-50 to TG BLOC86-100 coupling bush assembly	47
4.6	Anti-friction bearings.....	47
	4.6.1 General	47
	4.6.2 TG BLOC15-50 to TG BLOC86-100 disassembly	47
	4.6.3 TG BLOC15-50 to TG BLOC86-100 assembly.....	48
4.7	Mechanical seal.....	49
	4.7.1 General	49
	4.7.2 Preparation.....	49
	4.7.3 Special tools	49
	4.7.4 General instructions during assembly	49
	4.7.5 Assembly of the rotating part	49
	4.7.6 Assembly of the stationary seat	50
4.8	Pumps.....	50
	4.8.1 General	50
	4.8.2 TG BLOC15-50 to TG BLOC86-100	50
4.9	Relief valve.....	51
	4.9.1 Disassembly	51
	4.9.2 Assembly	51
5.0	Sectional drawings and part lists.....	52
5.1	TG BLOC15-50 to TG BLOC86-100.....	52
	5.2.1 Hydraulic part	53
	5.2.2 Bearing lantern	53
	5.2.3 Jacket.....	54
	5.2.4 Single mechanical seal.....	54
6.0	Dimensional drawings	55
6.1	Standard pump.....	55
	6.1.1 TG BLOC15-50 to 86-100	55
6.2	Flange connections	56

6.2.1	TG BLOC15-50 to 86-100	56
6.2.1.1	Cast iron.....	56
6.2.1.2	Stainless steel.....	57
6.3	Jackets (S) on pump cover and thread connection	57
6.3.1	TG BLOC15-50 to 86-100	57
6.4	Safety relief valves	58
6.4.1	Single safety relief valve.....	58
6.4.2	Double safety relief valve	58
6.4.3	Heated safety relief valve.....	59
6.4.4	Heated double safety relief valve.....	59
6.5	Weights – Mass	60

1.0 Introduction

1.1 General

This instruction manual contains necessary information on the TopGear pumps and must be read carefully before installation, service and maintenance. The manual must be kept easily accessible to the operator.

Important!

The pump must not be used for other purposes than recommended and quoted for without consulting your local supplier.



Liquids not suitable for the pump can cause damages to the pump unit, with a risk of personal injury.

1.2 Reception, handling and storage

1.2.1 Reception

Remove all packing materials immediately after delivery. Check the consignment for damage immediately on arrival and make sure that the name plate/type designation is in accordance with the packing slip and your order.

In case of damage and/or missing parts, a report should be drawn up and presented to the carrier at once. Notify your local supplier.

All pumps have the serial number stamped on a name plate.
This number should be stated in all correspondence with your local supplier.
The first digits of the serial number indicate the year of production.

EAC UK TopGear CE	
Model: TG	_____
Serial No:	_____
SPXFLOW	SPX Flow Europe Limited - Belgium Evenbroekveld 2-6, 9420 Erpe-Mere Johnson Pump www.johnson-pump.com / www.spxflow.com

1.2.2 Handling

Check the mass (weight) of the pump unit. All parts weighing more than 20 kg must be lifted using lifting slings and suitable lifting devices, e.g. overhead crane or industrial truck. See section 6.6 Weights – Mass.

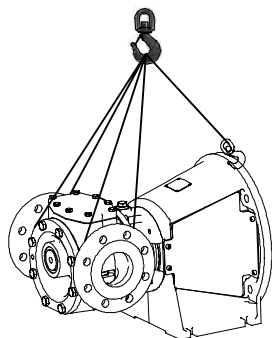

Always use two or more lifting slings. Make sure they are secured in such a way as to prevent them from slipping. The pump unit should be in a straight fashion.

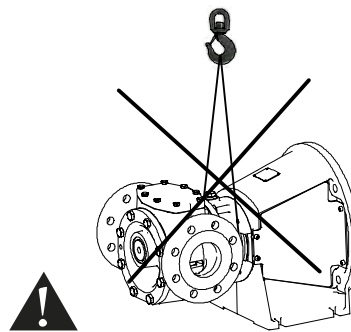

Never lift the pump unit with only two fastening points. Incorrect lift can cause personal injury and/or damage to the pump unit.

1.2.3 Storage

If the pump is not commissioned immediately, the shaft should be turned a full turn once every week. This ensures a proper distribution of the conservating oil.

1.3 Safety

1.3.1 General

Important!

The pump must not be used for other purposes than recommended and quoted for without consulting your local supplier.

A pump must always be installed and used in accordance with existing national and local sanitary and safety regulations and laws



- When ATEX pump/pump unit is supplied, the separate ATEX manual must be considered



- Always wear suitable safety clothing when handling the pump.



- Anchor the pump properly before start-up to avoid personal injury and/or damage to the pump unit.



- Install shut-off valves on both sides of the pump to be able to shut off the inlet and outlet before service and maintenance. Check to see that the pump can be drained without injuring anyone and without contaminating the environment or nearby equipment.

- Make sure that all movable parts are properly covered to avoid personal injury.

- All electrical installation work must be carried out by authorized personnel in accordance with EN60204-1 and/or local regulations. Install a lockable circuit breaker to avoid inadvertent starting. Protect the motor and other electrical equipment from overloads with suitable equipment. The electric motors must be supplied with ample cooling air.

In environments where there is risk of explosion, motors classified as explosion-safe must be used, along with special safety devices. Check with the governmental agency responsible for such precautions.



- Improper installation can cause fatal injuries.

- Dust, liquids and gases that can cause overheating, short circuits, corrosion damage and fire must be kept away from motors and other exposed equipment.



- If the pump handles liquids hazardous for person or environment, some sort of container must be installed into which leakage can be led. All (possible) leakage should be collected to avoid contamination of the environment.

- Keep arrows and other signs visible on the pump.



- If the surface temperature of the system or parts of the system exceeds 60°C, these areas must be marked with warning text reading "Hot surface" to avoid burns.



- The pump unit must not be exposed to rapid temperature changes of the liquid without prior pre-heating/pre-cooling. Big temperature changes can cause crack formation or explosion, which in turn can entail severe personal injuries.

- The pump must not operate above stated performance. See section 3.5 Main characteristics.

- Before intervening in the pump/system, the power must be shut off and the starting device be locked. When intervening in the pump unit, follow the instructions for disassembly/assembly, chapter 4.0. If the instructions are not followed, the pump or parts of the pump can be damaged. It will also invalidate the warranty.

- Gear pumps may never run completely dry. Dry running produces heat and can cause damage to internal parts such as bush bearings and shaft seal. When dry running is required, the pump has e.g. to be run a short time with liquid supply.

Note! A small quantity of liquid should remain in the pump to ensure lubrication of internal parts. If there is a risk for dry running for a longer period, install a suitable dry running protection. Consult your local supplier.

- If the pump does not function satisfactorily, contact your local supplier.

1.3.2 Pump units

1.3.2.1 Pump unit handling

Use an overhead crane, forklift or other suitable lifting device.

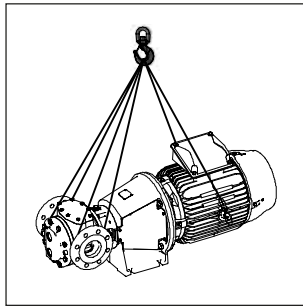

Secure lifting slings around the front part of the pump and the back part of the motor (if there are lifting rings on the motor the slings may be fastened to these). Make sure that the load is balanced before attempting the lift.
NB! Always use two lifting slings.

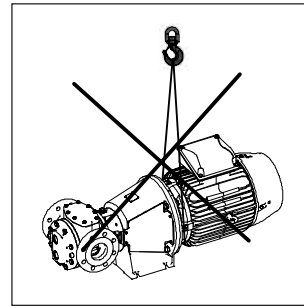

Warning
Never lift the pump unit with only one fastening point. Incorrect lifts can result in personal injury and/or damage to the unit.

1.3.2.2 Installation

All pump units should be equipped with a locking safety switch to prevent accidental start during installation, maintenance or other work on the unit.



Warning

The safety switch must be turned to off and locked before any work is carried out on the pump unit. Accidental start can cause serious personal injury.

The pump unit must be mounted on a level surface and either be bolted to the foundation or be fitted with rubber-clad feet.

The pipe connections to the pump must be stress-free mounted, securely fastened to the pump and well supported. Incorrectly fitted pipe can damage the pump and the system.



Warning

Electric motors must be installed by authorized personnel in accordance with EN60204-1. Faulty electrical installation can cause the pump unit and system to be electrified, which can lead to fatal injuries.

Electric motors must be supplied with adequate cooling ventilation. Electric motors must not be enclosed in airtight cabinets, hoods etc.

Dust, liquids and gases which can cause overheating and fire must be diverted away from the motor.



Warning

Pump units to be installed in potentially explosive environments must be fitted with an Ex-class (explosion safe) motor. Sparks caused by static electricity can give shocks and ignite explosions. Make sure that the pump and system are properly grounded. Check with the proper authorities for the existing regulations. A faulty installation can lead to fatal injuries.

1.3.2.3 Before commissioning the pump unit

Read the pump's operating and safety manual. Make sure that the installation has been correctly carried out according to the relevant pump's manual.

Check the alignment of the pump and motor shafts. The alignment may have been altered during transport, lifting and mounting of the pump unit.

Warning



The pump unit must not be used with other liquids than those for which it was recommended and sold. If there are any uncertainties contact your sales representative. Liquids, for which the pump is not appropriate, can damage the pump and other parts of the unit as well as cause personal injury.





1.3.2.4 Name plate – CE Declaration of Conformity

Always quote the serial number on the name plate together with questions concerning the pump unit, installation, maintenance etc.

When changing the operating conditions of the pump please contact your supplier to ensure a safe and reliable working pump.



This also applies to modifications on a larger scale, such as a change of motor or pump on an existing pump unit.

			SPX Flow Europe Limited - Belgium Evenbroekveld 2-6 9420 Erpe-Mere www.johnson-pump.com / www.spxflow.com
			
<hr/>			
Pump type:			
Article No.:			
Unit serial No.:			
Date:			
			

1.4 Technical conventions

Quantity	Symbol	Unit
Dynamic viscosity	μ	mPa·s = cP (Centipoise)
Kinematic viscosity	$\nu = \frac{\mu}{\rho}$	ρ = density $\frac{[\text{kg}]}{\text{dm}^3}$ ν = kinematic viscosity $[\frac{\text{mm}^2}{\text{s}}] = \text{cSt (Centistokes)}$
Note! In this manual only dynamic viscosity is used.		
Pressure	p	[bar]
	Δp	Differential pressure = [bar]
	p_m	Maximum pressure at discharge f ange (design pressure) = [bar]
Note! In this manual, unless otherwise specified - pressure is relative pressure [bar].		
Net Positive Suction Head	NPSHa	Net Positive Suction Head is the toal absolute inlet pressure at the pump suction connection, minus the vapour pressure of the pumped liquid. NPSHa is expressed in meter liquid column. It is the responsibility of the user to determine the NPSHa value.
	NPSHr	Net Positive Suction Head Required is the NPSH determined, after testing and calculation, by the pump manufacturer to avoid performance impairment due to cavitation within the pump at rate capacity. The NPSHr is measured at the suction f ange, at the point where the capacity drop results in a pressure loss of at least 4%.
Note! In this manual, unless otherwise specif ed, NPSH = NPSHr		
When selecting a pump, ensure that NPSHa is at least 1 m higher than the NPSHr.		

2.0 Pump description

TopGear BLOC pumps are rotary positive displacement pumps with internal gear. They are made of cast iron or stainless steel. TG BLOC pumps are assembled from modular elements, which allows a variety of constructions: heating / cooling jackets (steam), several sleeve bearings, gear and shaft materials and mounted relief valve.

2.1 Type designation

The pump properties are encoded in the following type indication, which is to be found on the name plate.

Example:

TG	BLOC	58-80		G2	S	SG	2	G1	AV
1	2	3	4	5	6	7	8	9	10

1. Pump family name

TG = TopGear

2. Pump range name

BLOC = Close-coupled pump with single mechanical seal

3. Hydraulics indicated with displacement volume per 100 revolution (in dm³) and nominal port diameter (in mm)

TG BLOC15-50

TG BLOC23-65

TG BLOC58-80

TG BLOC86-100

4. Application

Non-food

FD Food

5. Pump material & port connection type

G2 Pump in cast iron with PN16 f anges to DIN2533

G3 Pump in cast iron with PN20 f anges to ANSI 150 lbs

R2 Pump in stainless steel with PN25/PN40

R3 Pump in stainless steel with PN20 f anges to ANSI 150 lbs

R4 Pump in stainless steel with PN50 f anges to ANSI 300 lbs

R5 Pump in stainless steel with PN16 f anges to DIN2533

6. Jacket options for pump cover

O Pump cover without jackets

S Pump cover with jacket and thread connection

7. Idler bush and idler materials

SG Idler bush in hardened steel with idler in iron

CG Idler bush in carbon with idler in iron

BG Idler bush in bronze with idler in iron

BR Idler bush in bronze with idler in stainless steel

CR Idler bush in carbon with idler in stainless steel

UR Idler bush in hard metal with idler in stainless steel

Example:

TG BLOC 58-80 G2 S SG 2 G1 AV
1 2 3 4 5 6 7 8 9 10

8. Idler pin materials

- 2 Idler pin in hardened steel
- 4 Idler pin in kolsterised stainless steel
- 5 Idler pin in nitrided stainless steel

9. Rotor and shaft materials

- G1 Rotor in iron and shaft in steel
- G5 Rotor in iron and shaft in nitrided stainless steel
- R4 Rotor in stainless steel and shaft in stainless steel
- R5 Rotor in stainless steel and shaft in nitrided stainless steel

10. Shaft seal arrangement

Single mechanical seal Burgmann type MG12

- AV Single mech. seal Burgmann MG12 Carbon/SiC/FPM (Fluorocarbon)
- WV Single mech. seal Burgmann MG12 SiC/SiC/FPM (Fluorocarbon)

Single mechanical seal Burgmann type M7N

- HV Single mech. seal Burgmann M7N SiC/Carbon/FPM (Fluorocarbon)
- HT Single mech. seal Burgmann M7N SiC/Carbon/PTFE-wrapped
- WV Single mech. seal Burgmann M7N SiC/SiC/FPM (Fluorocarbon)
- WT Single mech. seal Burgmann M7N SiC/SiC/PTFE-FFKM

Single mechanical seal Roplan type RTI 239

- RV Single mech. seal Roplan RTI 239 SiC/Carbon/FPM (Fluorocarbon)

Single mechanical seal option without mechanical seal

- GS XX Single seal parts – seal on request

3.0 General technical information

3.1 Pump standard parts

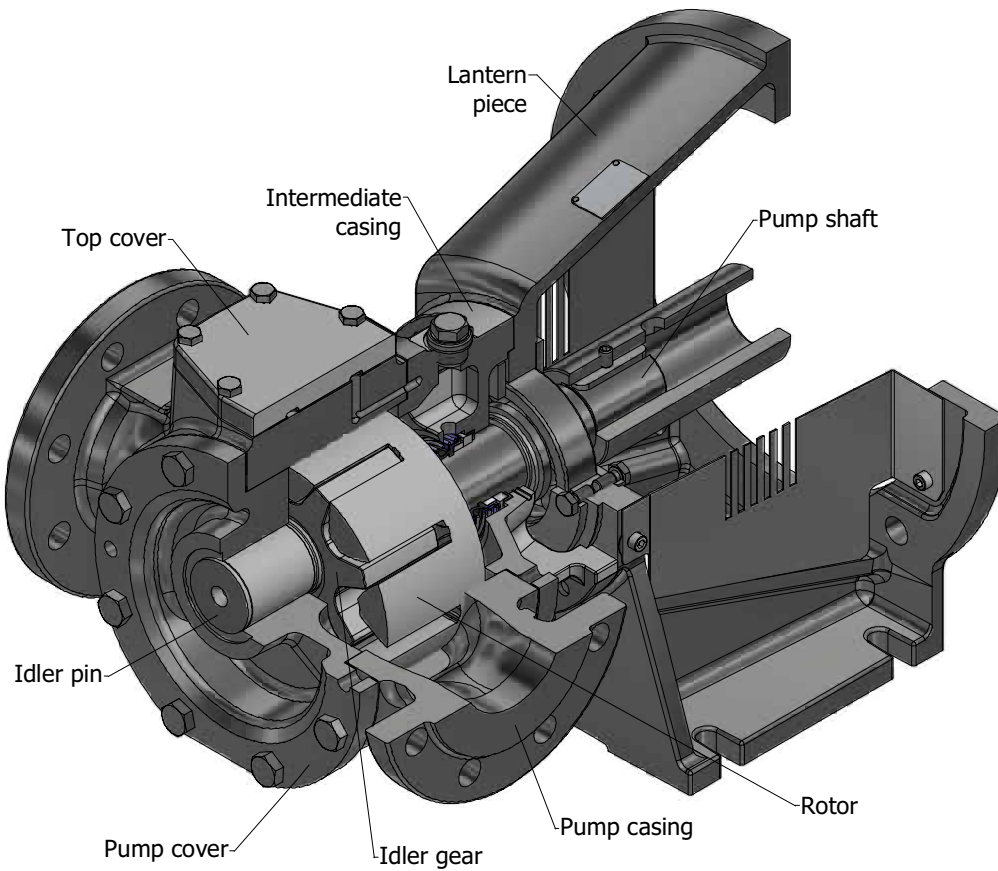

3.2 Operating principle

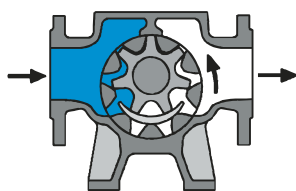

As the rotor and idler gear unmesh, an underpressure is created and the liquid enters the new created cavities.

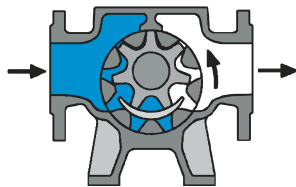

Liquid is transported in sealed pockets to the discharge side. The walls of the pump casing and the crescent are creating a seal and separate suction from discharge side.

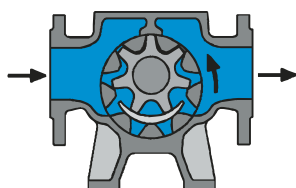

The rotor and idler gear mesh and liquid are being pushed into the discharge line.

Reversing the shaft rotation will reverse the flow through the pump as well.

3.2.1 Self-priming operation

TopGear pumps are self-priming when sufficient liquid is present in the pump to fill up the clearances and the dead spaces between the teeth. (For self-priming operation see also section 3.17.6.2 Piping).

3.2.2 Safety relief valve – Working principle

The positive displacement principle requires the installation of a safety relief valve protecting the pump against overpressure. It can be installed on the pump or in the installation.

This safety relief valve limits the differential pressure (Δp) between suction and discharge, not the maximum pressure within the installation.

For example, as media cannot escape when the discharge side of the pump is obstructed, an over-pressure may cause severe damage to the pump.

The safety relief valve provides an escape path, rerouting the media back to the suction side when reaching a specified pressure level.

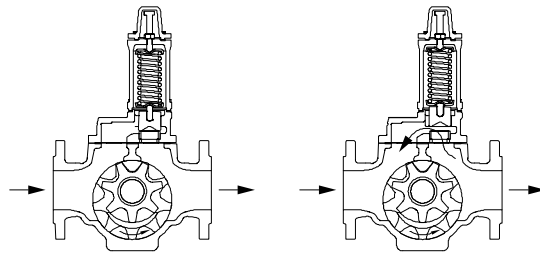

- The safety relief valve protects the pump against over-pressure only in one flow direction. The safety relief valve will **not** provide protection against over-pressure when the pump rotates in the opposite direction. When the pump is used in both directions, a double safety relief valve is required.
- An open safety relief valve indicates that the installation is not functioning properly. The pump must be shut down at once. Find and solve the problem before restarting the pump.
- When the safety relief valve is not installed on the pump, other protections against over-pressure have to be provided.
- **Note!** Do not use the safety relief valve as a flow regulator. The liquid will circulate only through the pump and will heat up quickly.
Contact your local supplier if a flow regulator is required.

3.3 Sound

TopGear pumps are rotary displacement pumps. Because of the contact between internal parts (rotor/idler), pressure variations etc. they produce more noise than for example centrifugal pumps. Also the sound coming from drive and installation must be taken into consideration. As the sound level at the operating area may exceed 85 dB(A), ear protection must be worn. See also section 3.7 Sound level.

3.4 General performance

Important!

The pump is calculated for the liquid transport as described in the quotation. Contact your local supplier if one or several application parameters change.

Liquids not suitable for the pump can cause damages to the pump unit and imply risk of personal injury.

Correct application requires that consideration be given to all of the following:

Product name, concentration and density. Product viscosity, product particles (size, hardness, concentration, shape), product purity, product temperature, inlet and outlet pressure, RPM, etc.

3.5 Main characteristics

The pump size is designated by the displacement volume of 100 revolutions expressed in litres (or dm³) but rounded followed by the nominal port diameter expressed in millimetres.

TG BLOC pump size	d (mm)	B (mm)	D (mm)	Vs-100 (dm ³)	n.max (min ⁻¹)	n.mot (min ⁻¹)	Q.th (l/s)	Q.th (m ³ /h)	v.u (m/s)	v.i (m/s)	Δp (bar)	p.test (bar)
15-50	50	40	100	14.5	1500		3.6	13.1	7.9	1.8	16	24
						1450	3.5	12.6	7.6	1.8		
23-65	65	47	115	22.7	1500		5.7	20.4	9.0	1.7	16	24
						1450	5.5	19.7	8.7	1.7		
58-80	80	60	160	57.6	1050		10.1	36.3	8.8	2.0	16	24
						960	9.2	33.2	8.0	1.8		
86-100	100	75	175	85.8	960	960	13.7	49.4	8.8	1.7	10	15

Legend

- d : port diameter (inlet and outlet port)
- B : width of idler gear and length of rotor teeth
- D : peripheral diameter of rotor (outside diameter)
- Vs-100 : displaced volume pro 100 revolutions
- n.max : maximum allowable shaft speed in rpm
- n.mot : normal speed of direct drive electric motor (at 50Hz frequency)
- Q.th : theoretical capacity without slip at differential pressure = 0 bar
- v.u : peripheral velocity of rotor
- v.i : velocity of liquid in the ports at Qth (inlet and outlet port)
- Δp : maximum working pressure = differential pressure
- p.test : hydrostatic test pressure

Shaft sealing type	Maximum viscosity (mPa·s) *)
	GS
Single mechanical seal	
GS with Burgmann MG12	3 000
GS with Burgmann M7N	5 000
GS with Roplan RTI 239	7 500

*) Remark:

Figures are for Newtonian liquids at operating temperature. The maximum allowable viscosity between the sliding faces of the mechanical seal depends on nature of liquid (Newtonian, plastic etc.), the sliding speed of the seal faces and the mechanical seal construction.

3.6 Pressure

Differential pressure or working pressure (p) is the pressure on which the pump normally operates. TopGear BLOC-line has the maximum differential pressure at 16 bar. (86-100 10 bar)

The hydrostatic test pressure is 1.5 times the differential pressure i.e.:
TopGear BLOC-line has the hydrostatic test pressure at 24 bar (86-100 15 bar).

Following figure gives a graphical presentation of the several kinds of pressures.

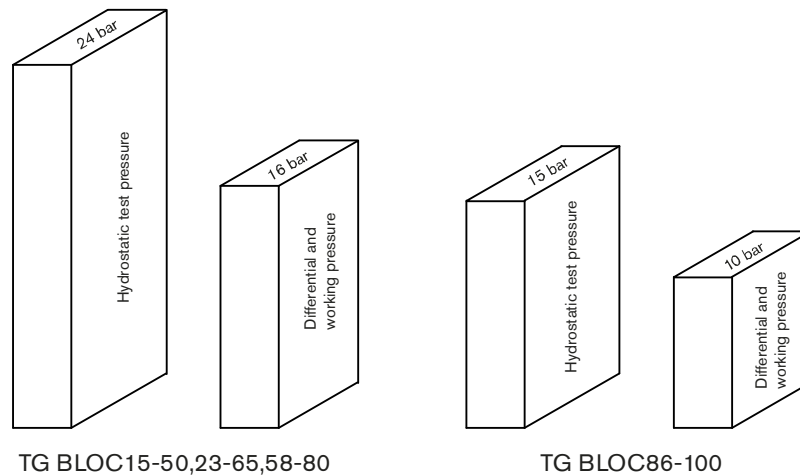

3.7 Sound level

3.7.1 Sound level of a pump without drive

Sound pressure level (L_{pA})

The following table gives an overview of the A-weighted sound pressure level, L_{pA} emitted by a pump without drive, measured according to ISO3744 and expressed in decibels dB(A). The reference sound pressure is $20\mu\text{Pa}$.

The values depend on the position from where one measures and were therefore measured at the front of the pump, at distance of 1 meter from the pump cover and were corrected for background noise and reflections.

The values listed are the highest measured values under following operating conditions.

- working pressure: up to 10 bar.
- pumped medium: water, viscosity = 1 mPa·s
- $\% n_{\max} = \%$ maximum shaft speed

TG BLOC Pump size	$n_{\max}(\text{min-1})$	Lpa (dB(A))				Ls (dB(A))
		25% n_{\max}	50% n_{\max}	75% n_{\max}	100% n_{\max}	
15-50	1500	61	72	79	83	9
23-65	1500	63	75	81	85	10
58-80	1050	67	79	85	89	10
86-100	960	69	80	86	90	11

Sound power level (L_{WA})

The sound power L_W is the power emitted by the pump as sound waves and is used to compare sound levels of machines. It is the sound pressure L_p that acts on a surrounding surface at distance of 1 meter.

$$L_{WA} = L_{pA} + L_s$$

The A-weighted sound power level L_{WA} is also expressed in decibels dB(A). The reference sound power is 1 pW (= 10^{-12} W). L_s is the logarithm of the surrounding surface at distance of 1 metre from the pump, expressed in dB(A) and is listed in the last column of above table.

3.7.2 The sound level of the pump unit

The sound level of the drive (motor, transmission, . . .) must be added to the sound level of the pump itself to determine the total sound level of the pump unit. The sum of several sound levels must be calculated logarithmically.

For a quick determination of the total sound level the following table can be used:

$L_1 - L_2$	0	1	2	3	4	5	6
$L[f(L_1 - L_2)]$	3.0	2.5	2.0	1.7	1.4	1.2	1.0

$$L_{\text{total}} = L_1 + L_{\text{corrected}}$$

where

- L_{total} : the total sound level of the pump unit
- L_1 : the highest sound level
- L_2 : the lowest sound level
- $L_{\text{corrected}}$: term, depending on the difference between both sound levels

For more than two values this method can be repeated.

Example:

- Drive unit : $L_1 = 79 \text{ dB(A)}$
- Pump : $L_2 = 75 \text{ dB(A)}$
- Correction : $L_1 - L_2 = 4 \text{ dB(A)}$
- According to the table : $L_{\text{corrected}} = 1.4 \text{ dB(A)}$
- $L_{\text{total}} = 79 + 1.4 = 80.4 \text{ dB(A)}$

3.7.3 Influences

The real sound level of the pump unit can for several reasons deviate from the values listed in the tables above.

- Noise production decreases when pumping high viscosity liquids due to better lubricating and damping properties. Moreover the resistance torque of the idler is increasing due to higher liquid friction which results in lower vibration amplitude.
- Noise production increases when pumping low viscosity liquids combined with low working pressure because the idler can move freely (lower charge, lower liquid friction) and the liquid does not damp much.
- Vibrations in piping, vibrating of the baseplate etc. will make the installation produce more noise.

3.8 Material options

The overall temperatures for selected casing materials are shown in below table.

TG BLOC pump size	Minimum allowable temperature (°C)		Maximum allowable temperature (°C)	
	Casing materials		Casing materials	
	Cast iron (C)	Stainless steel (R)	Cast iron (C)	Stainless steel (R)
15-50	-10	-40	+300	+250
23-65				
58-80				
86-100				

Remarks:

1. Temperature limits must be considered depending on the used materials for bearing bushes and shaft sealing.

3.9 Jacket options

S-jackets are designed for use with saturated steam or with non-dangerous media. They are provided with cylindrical threaded connections according to ISO 228-I.

Maximum temperature: 180°C

Maximum pressure: 10 bar

Material: Cast iron GG25

3.10 Internals

3.10.1 Bush materials

Overview of bush materials and application field

Material Code	S	C	B
Material	Steel	Carbon	Bronze
Hydrodynamic lubrication	if yes	to maximum working pressure = 16 bar	
	if no	6 bar (*)	10 bar (*)
Corrosive resistance	Fair	Good	Fair
Abrasive resistance	Slight	None	None
Dry running allowed	No	Yes	Moderate
Sensitive to thermal choc	No	No	No
Sensitive to blistering in oil	No	> 180°C	No
Oil aging	No	No	> 150°C
Food processing allowed	Yes	No (antimony)	No (lead)

(*) These are not absolute figures. Higher or lower values possible in function of the application, expected lifetime etc.

3.10.2 Maximum temperature of internals

Because the overall temperature of TopGear BLOC pumps is limited to 180°C, there are no extra temperature restrictions for internals.

3.10.3 Operation under hydrodynamic lubrication conditions

Hydrodynamic lubrication could be important criteria for bush material selection.

If the bush bearings are running under the condition of hydrodynamic lubrication there is no more material contact between bush and pin or shaft and the lifetime cycle is increased importantly.

If there is no condition for hydrodynamic lubrication, the bush bearings make material contact with pin or shaft and the wear of these parts is to be considered.

The condition of hydrodynamic lubrication is fulfilled with the following equation:

$$\text{Viscosity} * \text{shaft speed} / \text{diff.pressure} \geq \text{K.hyd}$$

with: viscosity [mPa·s]
shaft speed [rpm]
diff.pressure [bar]

K.hyd = design constant for each pump size.

TG BLOC pump size	K.hyd
15-50	6250
23-65	4000
58-80	3750
86-100	3600

3.10.4 Maximum torque of pump shaft and rotor material combination

The maximum allowable torque is a constant independent from speed and may not be exceeded to avoid damaging the pump i.e. pump shaft, rotor/shaft fitting and rotor teeth.

TG BLOC pump size	Mn (nominal torque) in Nm		Md (starting torque) in Nm	
	G Rotor Iron	R Rotor Stainless steel	G Rotor Iron	R Rotor Stainless steel
15-50	255	255	360	360
23-65	255	255	360	360
58-80	390	390	550	550
86-100	600	600	840	840

The nominal torque (Mn) has to be checked for the normal working conditions and the installed nominal motor torque (Mn.motor) but converted to the pump shaft speed.

The starting torque (Md) may not be exceeded during start up. Use this value for the maximum torque set of a torque limiter if installed on the pump shaft.

3.11 Mass moment of inertia

TG BLOC	15-50	23-65	58-80	86-100
J (10 ⁻³ x kg·m ²)	3.5	6.8	32	54

3.12 Radial clearances

TG BLOC	15-50	23-65	58-80	86-100
Minimum (µm)	70	75	100	115
Maximum (µm)	150	165	200	225

3.13 Play between gear teeth

TG BLOC	15-50	23-65	58-80	86-100
Minimum (µm)	360	400	400	400
Maximum (µm)	720	800	800	800

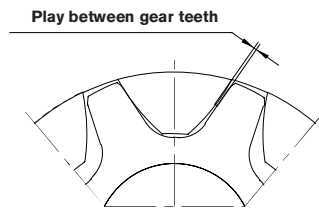

3.14 Maximum size of solid particles

TG BLOC	15-50	23-65	58-80	86-100
Size (µm)	120	125	150	165

3.15 Shaft sealing

Mechanical seal according to EN12756 (DIN24960) – General information

In TopGear TG BLOC the short EN12756 (DIN24960) single mechanical seal can be built in. The mechanical seal is set against the rotor shoulder.

TG BLOC pump size	15-50 23-65	58-80 86-100
Shaft diameter	40	45
Short EN12756 (DIN 24960)	KU040	KU045
L1K (short KU)	45	45

Dimensions in mm

Performance

Maximum performance such as viscosity, temperature and working pressure depends on the make of the mechanical seal and the used materials.

The following basic values can be taken into consideration:

Maximum temperatures of elastomers

Nitrile (P):	110°C
FPM (Fluorocarbon):	180°C
PTFE (solid or PTFE wrapped):	220°C
Chemraz:	230°C
Kalrez®*:	250°C

* Kalrez® is a registered trademark of DuPont Performance Elastomers

Maximum viscosity

3000 mPas:	For single mechanical seals of light construction
5000 mPas:	For single mechanical seals of medium torque construction (consult manufacturer).
7500 mPas:	For single mechanical seals of high torque construction (consult manufacturer).

The maximum allowed viscosity between the sliding faces of the mechanical seal depends on the nature of the liquid (Newtonian, plastic etc.), the sliding speed of the seal faces and the mechanical construction.

3.16 Safety relief valve

Example

V 35 - G 10 H
1 2 3 4 5

1. Safety relief valve = V

2. Type indicating = inlet diameter (in mm)

27 Safety relief valve size for
TG BLOC15-50, TG BLOC23-65

35 Safety relief valve size for
TG BLOC58-80

50 Safety relief valve size for
TG BLOC86-100

3. Materials

G Safety relief valve in cast iron

R Safety relief valve in stainless steel

** for food applications: a stainless steel safety relief valve should be used*

4. Working pressure class

4 Working pressure 1-4 bar

6 Working pressure 3-6 bar

10 Working pressure 5-10 bar

16 Working pressure 9-16 bar

5. Heated spring casing

H Safety relief valve heated spring casing

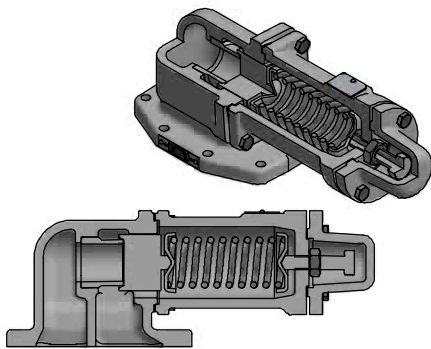

Safety relief valve – horizontal

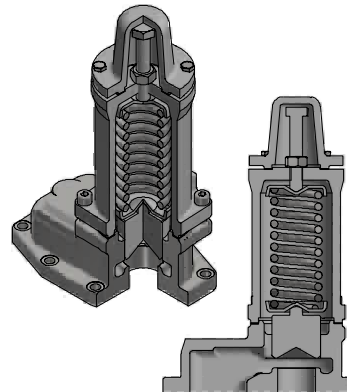

Safety relief valve – vertical

3.16.1 Pressure

Safety relief valves are divided into 3 working pressure classes i.e. 4, 6 and 10 indicating the maximum working pressure for that valve. Each class has a standard set pressure at 1 bar above the indicated maximum working pressure. The set pressure can be set lower on request never higher.

Working pressure class	4	6	10	16
Standard set pressure (bar)	5	7	11	17
Working pressure range (bar)	1 – 4	3 – 6	5 – 10	9 – 16
Set pressure range (bar)	2 – 5	4 – 7	6 – 11	10 – 17

3.16.2 Heating

The weld on spring casing is provided with 2 thread connections. Flange connections are not available.

Maximum temperature: 200°C

Maximum pressure: 10 bar

3.16.3 Safety relief valve – Relative adjustment

Adjustment of the standard setting pressure is performed at the factory.

Note! When testing the safety relief valve mounted on the pump, make sure the pressure never exceeds the set pressure of the valve + 2 bar.

To adjust the standard opening pressure, proceed as follows:

1. Loosen the tap bolts (7310).
2. Remove cover (7050).
3. Take the measurement of dimensions of H.
4. Read spring ratio in the below table and determine the distance over which the adjusting bolt (7320) must be loosened or tightened.

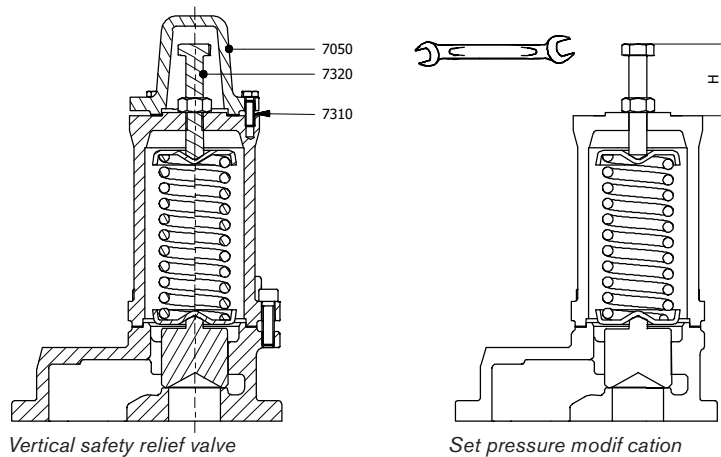

Spring ratio – Safety relief valve

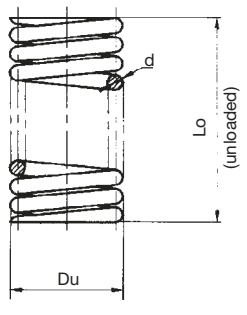
TG BLOC Pump size			Spring dimensions						
			Pressure class	Du mm	d mm	Lo mm	p/f bar/mm	ΔH [mm] in order to adjust by 1 bar	
15-50 23-65	V27	Horizontal	4	37.0	4.5	93	0.21	4,76	
			6	37.0	4.5	93	0.21	4,76	
			10	36.5	6.0	90	0.81	1,23	
58-80	V35	Vertical	4	49.0	7.0	124	0.32	3,13	
			6	49.0	7.0	124	0.32	3,13	
			10	48.6	8.0	124	0.66	1,52	
86-100	V50	Vertical	4	49.0	7.0	124	0.16	6,25	
			6	48.6	8.0	124	0.33	3,03	
			10	49.0	9.0	120	0.55	1,82	

Example: adjust the standard set pressure of a V35-G10 valve (for pump size 58-80) to 8 bar.
 ⇨ Standard set pressure of V35-G10 = 11 bar (see table under 3.17.1)
 ⇨ Difference between actual set pressure and desired set pressure = 11 - 8 = 3 bar
 ⇨ ΔH to loosen the adjusting bolt = 3 x 1.52 mm (see table above) = 4.56 mm

Note!

The spring ratio p/f depends upon the dimensions of the spring. Check these dimensions if necessary (see table above).

When the safety relief valve is not functioning properly, the pump must immediately be taken out of service. The safety relief valve must be checked by your local distributor.

3.16.4 Sectional drawings and part lists

3.16.4.1 Single safety relief valve

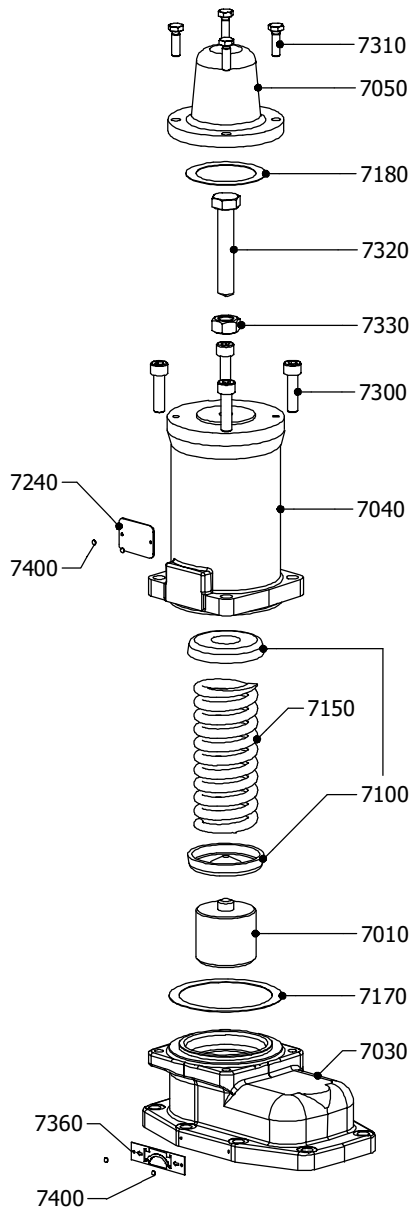
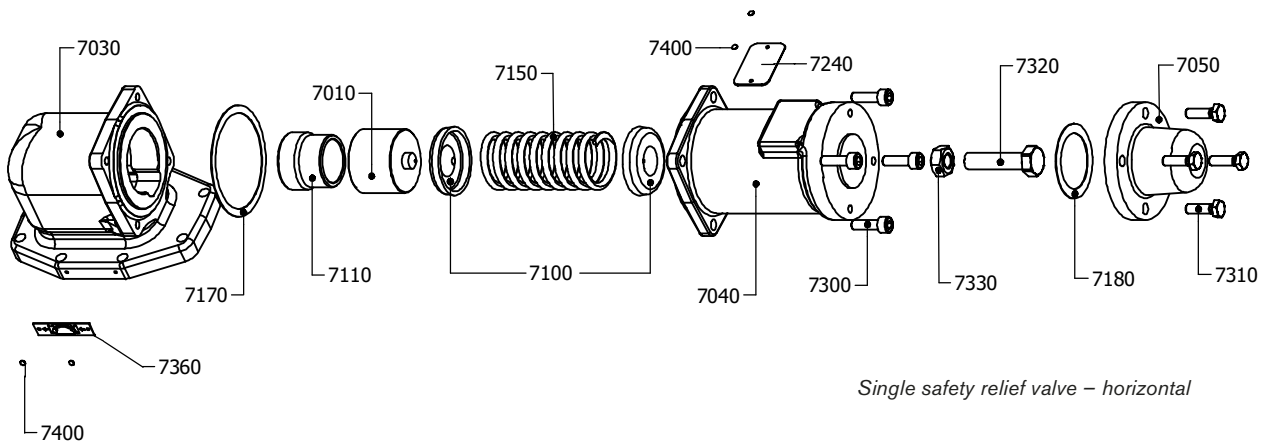

Single safety relief valve – vertical

Pos.	Description	V27	V35	V50	Preventive	Overhaul
7010	Valve	1	1	1		
7030	Valve casing	1	1	1		
7040	Spring casing	1	1	1		
7050	Cover	1	1	1		
7100	Spring plate	2	2	2		
7110	Valve seat	1	1	1		
7150	Spring	1	1	1		
7170	Flat gasket	1	1	1	x	x
7180	Flat gasket	1	1	1	x	x
7240	Name plate	1	1	1		
7300	Allen screw	4	4	4		
7310	Tap bolt	4	4	4		
7320	Adjusting screw	1	1	1		
7330	Hexagonal nut	1	1	1		
7360	Arrow plate	1	1	1		
7400	Rivet	4	4	4		

3.16.4.2 Heated spring casing

Pos.	Description	V27	V35	V50	Preventive	Overhaul
7041	Heated spring casing	1	1	1		

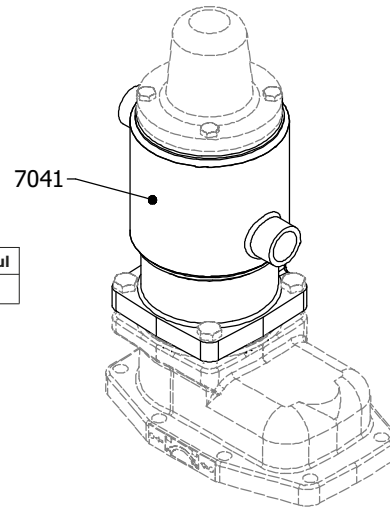

3.16.4.3 Double safety relief valve

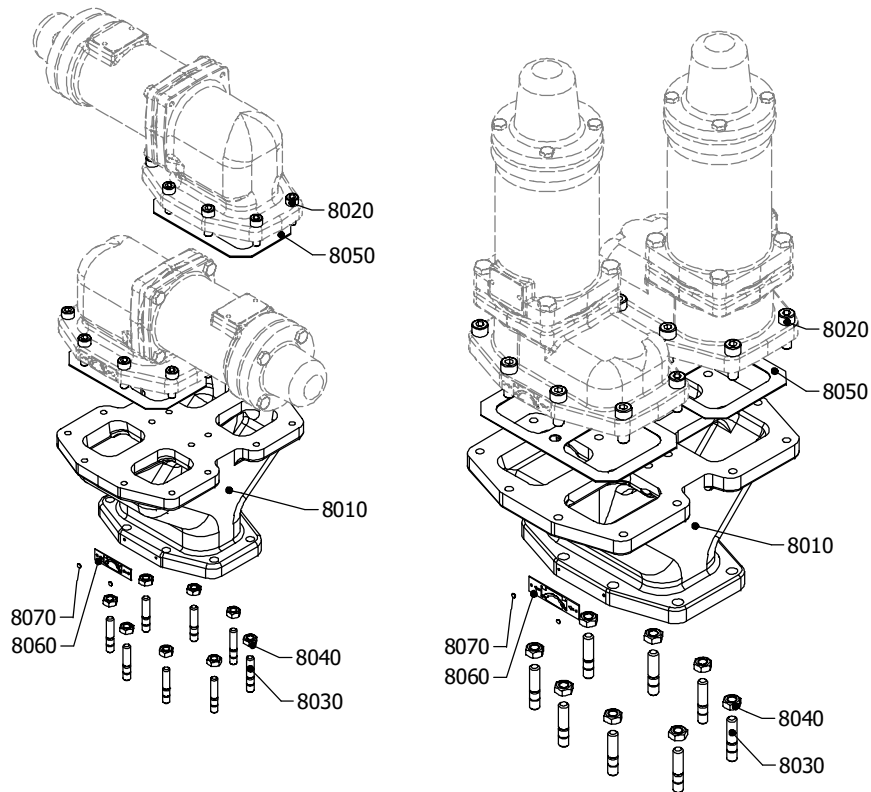

Double safety relief valve – horizontal

Double safety relief valve – vertical

Pos.	Description	V27	V35	V50	Preventive	Overhaul
8010	Y-casing	1	1	1		
8020	Allen screw	16	16	16		
8030	Stud bolt	8	8	8		
8040	Hexagonal nut	8	8	8		
8050	Flat gasket	3	3	3	x	x
8060	Arrow plate	1	1	1		
8070	Rivet	2	2	2		

3.17 Installation

3.17.1 General

This manual gives basic instructions which are to be observed during installation of the pump. It is therefore important that this manual is read by the responsible personnel prior to assembly and afterward to be kept available at the installation site.

The instructions contain useful and important information allowing the pump/pump unit to be properly installed. They also contain important information to prevent possible accidents and serious damage prior to commissioning and during operation of the installation.



Non-compliance with the safety instructions may produce a risk to the personnel as well as to the environment and the machine, and results in a loss of any right to claim damages.

It is imperative that signs affixed to the machine, e.g. arrow indicating the direction of rotation or symbols indicating fluid connections is observed and kept legible.

3.17.2 Location

3.17.2.1 Short suction line

Locate the pump/pump unit as close as possible to the liquid source and if possible below the liquid supply level. The better the suction conditions, the better the performance of the pump. See also section 3.17.6.2 Piping.

3.17.2.2 Accessibility

Sufficient room should be left around the pump/pump unit to allow proper inspection, pump isolation and maintenance.

Sufficient space should be left in front of the pump to enable disassembly of the pump cover, idler and idler pin.

- For loosening pump cover refer to **ma**
- For disassembling rotating parts (pump shaft and sealing) refer to **mb**
- To adjust pressure of safety relief valve refer to **mc**

For dimensions of ma, mb, mc see chapter 6.0.

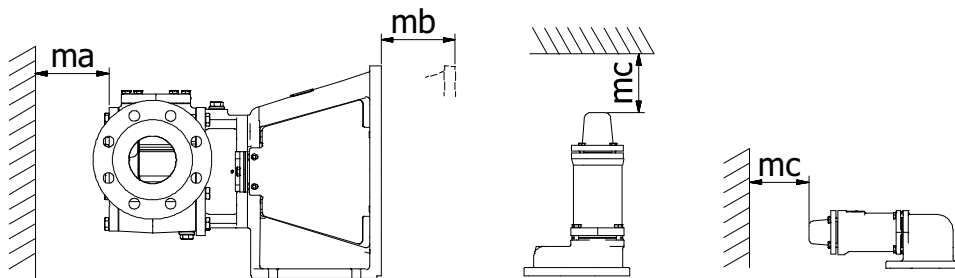

It is imperative that the operating device of pump and/or pump unit is always accessible (also during operation).

3.17.2.3 Outdoor installation

The TG BLOC pump may be installed in the open, the ball bearing is sealed protecting the pump against dripping water. In very wet conditions we advise to install a roof.

3.17.2.4 Indoor installation

Locate the pump so that the motor can be vented properly. Prepare the motor for operation according to instructions provided by the motor manufacturer.

When flammable or explosive products are pumped, a proper earthing should be provided. The components of the unit should be connected with earthing bridges to reduce the danger arising from static electricity.



Use explosion free or explosion proof motors according to local regulations. Provide suitable coupling guards and suitable couplings.

Excessive temperatures

Depending on the fluid being pumped, high temperatures may be reached inside and around the pump. From 60°C onwards the responsible person must provide the necessary protective means and place "Hot surfaces" notices.



When insulating the pump unit, ensure that adequate cooling is allowed from the lantern piece. This is required for cooling of the bearings.



Protect the user against leakages and possible liquid streams.

3.17.2.5 Stability

Foundation

The pump unit must be installed on a base plate or on a frame placed exactly level on the foundation. The foundation must be hard, level, flat, vibration free to guarantee correct alignment of the pump/drive while operating. See also section 3.17.9 Guidelines for assembly

Horizontal mounting

Pumps are to be mounted horizontally on the lantern piece feet. Other kinds of installation have an influence on draining, filling and functioning of the mechanical seal, etc. If the pump/pump unit is installed differently, contact your local supplier.

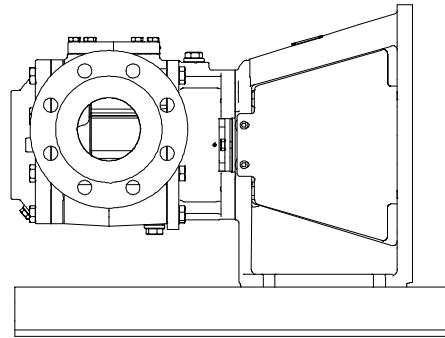

3.17.3 Drives

If a bare shaft pump is supplied, the user is responsible for the drive and the assembling with the pump. See also section 3.17.9 Guidelines for assembly.

3.17.3.1 Starting torque

- The starting torque of internal gear pumps is almost identical to the nominal torque.
- Take care that the motor has a sufficiently large starting torque. Therefore choose a motor with a capacity 25% higher than the pump power consumption.

Note! A mechanical variable speed drive requires checking of the available torque at low and high speed.

- Frequency invertors may have limited the starting torques.
- Also verify that the maximum allowable torque at the pump shaft is not exceeded (see section 3.10.4). In critical cases a torque-limiting device such as a slip or break coupling can be provided.

3.17.4 Shaft rotation for pump without safety relief valve

The shaft rotation determines which port of the pump is suction and which is discharge. The relation between the shaft rotation and the suction/discharge side is indicated by the rotation arrow plate attached at the top cover of a pump without safety relief valve.

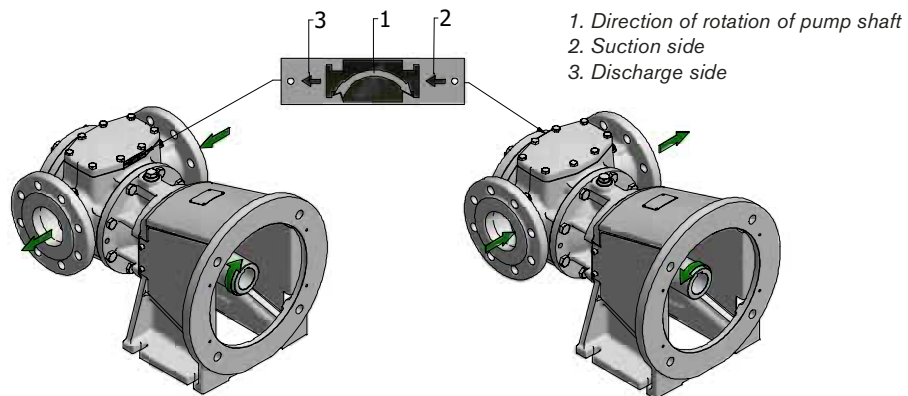

Note! Shaft rotation is always viewed from the shaft end towards the pump. Unless otherwise specified on the order, TopGear pumps are built at the factory for clockwise rotation (left figure above), which we define as the standard direction of rotation.



The small arrows 2 and 3 indicate the flow direction of the pumped liquid. Always make sure that shaft rotation corresponds with the position of the discharge and suction ports and the direction indicated by the rotation arrow plate.

If the shaft rotation is correct in relation to the port position but different from the direction indicated by rotation arrow plate, the top cover must be disassembled and turned around by 180°. The two suck-back grooves will help to evacuate air or gases during start-up or whilst running. As they only function in one direction of rotation, the top cover should be positioned in such a way that the suck-back grooves are placed towards the suction side. In case of doubt, contact your local distributor.

If the pump rotates in both directions, the top cover should be positioned in such a way that the suck-back grooves are placed towards the most used suction side.

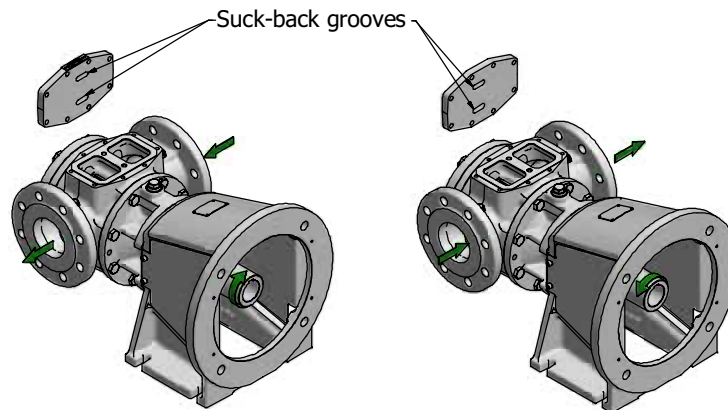

3.17.5 Shaft rotation for pump with safety relief valve

The shaft rotation determines which port of the pump is suction and which is discharge. The relation between the shaft rotation and the suction/discharge side is indicated by the rotation arrow plate attached at the valve casing of the safety relief valve.

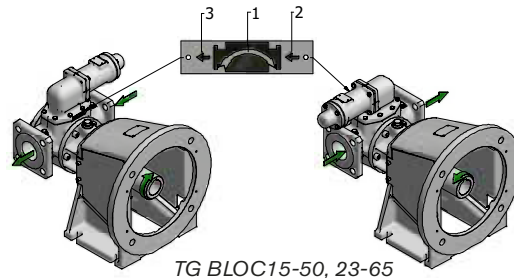

TG BLOC15-50, 23-65

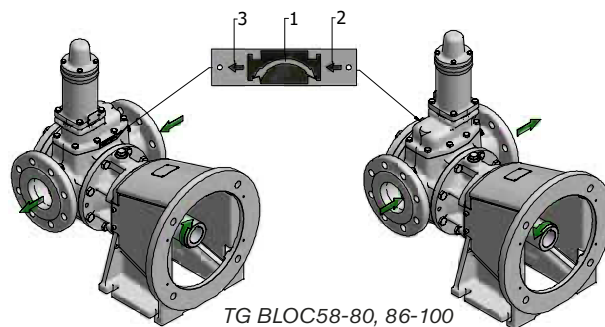

TG BLOC58-80, 86-100

Note! Shaft rotation is always viewed from the shaft end towards the pump. Unless otherwise specified on the order, TopGear pumps are built at the factory for clockwise rotation (left figures above), which we define as the standard direction of rotation.



The small arrows 2 and 3 indicate the flow direction of the pumped liquid. Always make sure that shaft rotation corresponds with the position of the discharge and suction ports and the direction indicated by the rotation arrow plate.

If the shaft rotation is correct in relation to the port position but different from the direction indicated by rotation arrow plate, the safety relief valve must be disassembled and turned around by 180°.

If the pump rotates in both directions, a double safety relief valve is required.

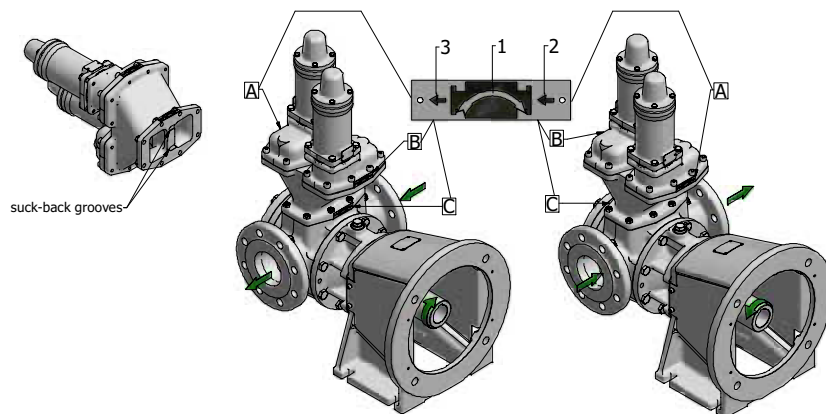

When a double safety relief valve is installed three arrow plates are attached – one on each valve (A and B) indicating the liquid flow direction of each valve (small arrows 2 and 3) and one on the Y-casing (C) indicating the most favourable direction of rotation of the pump (arrow 1).

The two suck-back grooves will help to evacuate air or gases during start-up or whilst running. As they only function in one direction of rotation, the Y-casing should be positioned in such a way that the suck-back grooves are placed towards the most used suction side.

In case of doubt, contact your local distributor.

Be sure that the safety relief valves are mounted opposite each other so that the arrow plates on the safety relief valves (A and B) are indicating opposite liquid flow directions.

3.17.6 Suction and discharge pipes

3.17.6.1 Forces and moments

Note! Excessive forces and moments on the nozzle flanges derived from piping can cause mechanical damage to pump or pump unit.

Pipes should therefore be connected in line, limiting the forces on the pump connections.

Support the pipes and make sure they remain stress-free during operation of the pump.

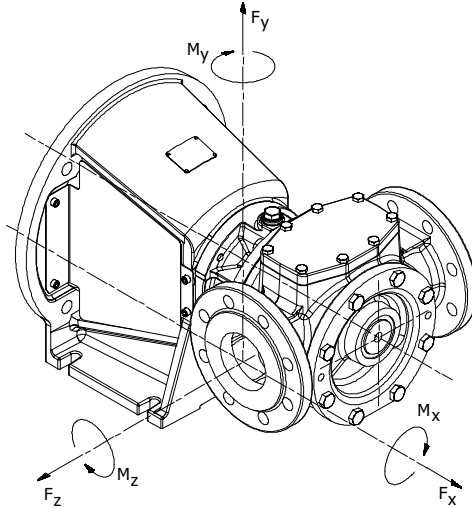

TG BLOC pump size	$F_{x,y,z}$ (N)	$M_{x,y,z}$ (Nm)
15-50	2600	675
23-65	2900	800
58-80	3550	1375
86-100	4100	1750

See table for maximum allowable forces ($F_{x,y,z}$) and moments ($M_{x,y,z}$) on the nozzle flanges with pump on a solid foundation (e.g. grouted base plate or solid frame).

When pumping hot liquids attention should be given to forces and moments caused by thermal expansion in which case expansion joints should be installed.

Check after connecting whether the shaft can move freely.

3.17.6.2 Piping

- Use piping with an equal diameter than the connection ports of the pump and shortest possible.
- The pipe diameter has to be calculated in function of the liquid parameters and the installation parameters. If necessary use larger diameters to limit pressure losses.
- If the fluid to be pumped is viscous, pressure losses in the suction and discharge lines may increase considerably. Other piping components like valves, elbows, strainers, filters and foot valve also cause pressure losses.
- Diameters, length of piping and other components should be selected in such a way that the pump will operate without causing mechanical damage to the pump/pump unit, taking into account the minimum required inlet pressure, the maximum allowable working pressure and the installed motor power and torque.
- Check the tightness of the pipes after connection.

Suction piping

- Liquids should preferably enter the pump from a level higher than the pump level. In case the liquid should be sucked from a level lower than the pump level, the inclining suction pipe should rise upwards towards the pump without any air pockets.
- A too small diameter or a too long suction pipe, a too small or blocked strainer will increase pressure losses so that the NPSHa (NPSH available) becomes smaller than the NPSH (NPSH required).

Cavitation will occur, causing noise and vibrations. Mechanical damage to pump and pump unit is not excluded.

- When a suction strainer or filter is installed pressure losses in the suction line must be checked constantly. Also check if the inlet pressure at the suction flange of the pump is still sufficiently high.
- When the pump works in both directions, pressure losses must be calculated for both directions.

Self-priming operation

At the start sufficient liquid must be available in the pump filling up the internal clearance volume and the dead spaces, allowing the pump to build up a pressure difference.

Therefore, for pumping low viscosity fluids, a foot valve with the same or larger diameter than the suction pipe must be installed or the pump can be installed without foot-valve but in U-line.

Note! A foot valve is not recommended when pumping high viscous liquids.

- To remove air and gases from suction line and pump, counter pressure at the discharge side must be reduced. In case of self-priming operation, start-up of the pump should be performed with open and empty discharge line allowing air or gases to escape at low back pressure.
- Another possibility in case of long lines or when a non-return valve is installed in the discharge line, is to install a by-pass with isolating valve close to the discharge side of the pump. This valve will be opened in case of priming and allows air or gas evacuation at low back pressure. The bypass should be lead back to the supply tank – not to the suction port.

3.17.6.3 Isolating valves

To allow proper maintenance it is necessary to be able to isolate the pump. Isolation can be done by installing valves in suction and discharge lines.

- These valves must have a cylindrical passage of the same diameter of the piping (full bore). (Gate or ball valves are preferable).
- When operating the pump, the valves must be opened completely. The output must never be regulated by means of closing valves in suction or discharge pipes. It must be regulated by changing shaft speed or by re-routing the media over a by-pass back to the supply tank.

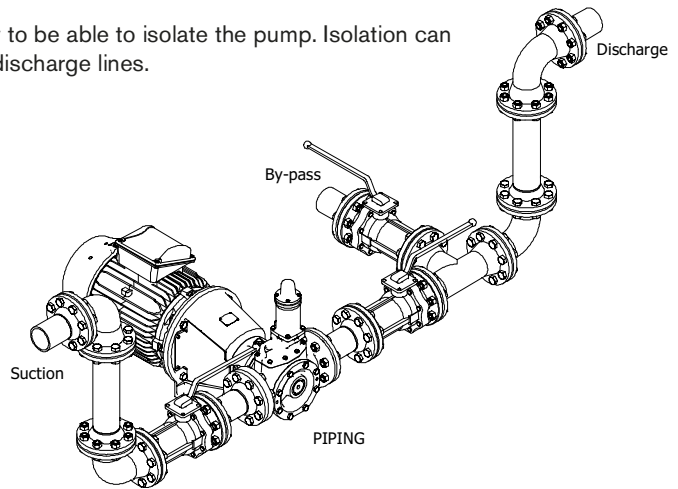

3.17.6.4 Strainer

Foreign particles can seriously damage the pump. Avoid the entry of these particles by installing a strainer.

- When selecting the strainer attention should be given to the size of the openings so that pressure losses are minimised. The cross-sectional area of the strainer must be three times that of the suction pipe.
- Install the strainer in such a way that maintenance and cleaning are possible.
- Make sure that the pressure drop in the strainer is calculated with the right viscosity. Heat the strainer if necessary to reduce viscosity and pressure drop.

For the maximum allowable particle size see section 3.14.

3.17.7 Secondary piping

For dimensions of connections and plugs see chapter 6.0.

3.17.7.1 Drain lines

The pump is provided with drain plugs.

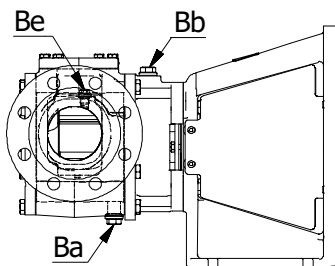

3.17.7.2 Heating jackets

1. S-type jackets

The S-jackets are designed for use with saturated steam (max 10 bar, 180°C) or with non-dangerous media. They are provided with threaded connections BI (see chapter 6.0 for the dimensions).

The connection can be done by threaded pipes or pipe connections with sealing in the thread (conical thread applying ISO 7/1) or sealed outside the thread by means of f at gaskets (cylindrical thread applying ISO 228/1). Thread type see section 3.20.7.

S-jacket on pump cover

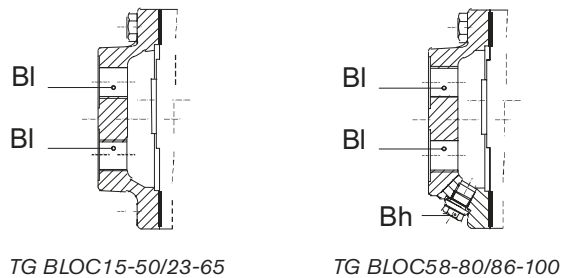

2. Jacket on pump cover

In case of steam supply, connect the supply line at the highest position and the return line to the lowest position so that condensed water will be drained via the lowest line. In case of liquid supply, the positions are not important. A drain plug Bh is provided and can be considered as a drain line (in cast iron version Bh provided only in TG BLOC58-80 and TG BLOC86-100 model).

3. Jackets on safety relief valve – around spring casing

The jackets on the safety relief valve are designed for use with saturated steam (max 10 bar, 180°C) or with non dangerous media. They are provided with threaded connections B0 (see chapter 6.0 for dimensions). The connection can be done by threaded pipes or pipe connections with sealing in the thread (conical thread applying ISO 7/1). Thread type see section 3.20.7.

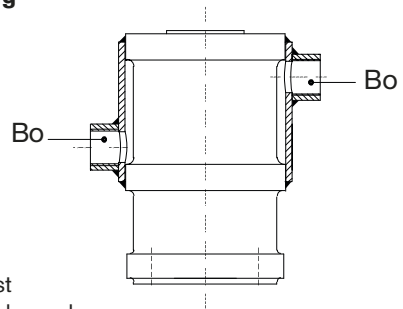

In case of steam supply, connect the supply line at the highest position and the return line to the lowest position so that condensed water will be drained via the lowest line. In case of liquid supply, the positions are not important.

3.17.8 Flush media

The TopGear BLOC pumps are provided of a flush room around the mechanical seal with threaded connections Bb at top

The room can be connected to a tank supply installed above pump level or to an external flush supply line at low pressure (max. pressure 0.5 bar).

Attention should be given to compatibility of flush medium towards

- nitril rubber of radial lipring
- ball bearing grease because medium could leak in very small quantities towards the ball bearing.

Use for example clean lubrication oil ISO VG32.

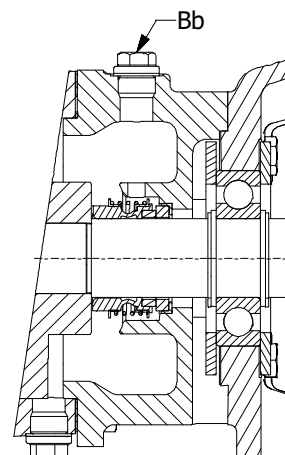

3.17.9 Guidelines for assembly

When a bare shaft pump is delivered, the assembly with drive is the responsibility of the user. The user also must provide all necessary devices and equipment allowing a safe installation and commissioning of the pump.

3.17.9.1 Transport of pump unit

- Prior to lifting and transporting a pump unit, make sure that the packaging is of sturdy enough construction and will not be damaged during transport.
- Use crane hooks for lifting the pump unit. (See chapter 1.0.)

3.17.9.2 Foundation pump unit

The pump unit must be installed on a base plate or on a frame placed exactly level on the foundation. The foundation must be hard, level, flat and vibration free in order to guarantee the alignment of pump/drive while operating. (See section 3.17.2.5)

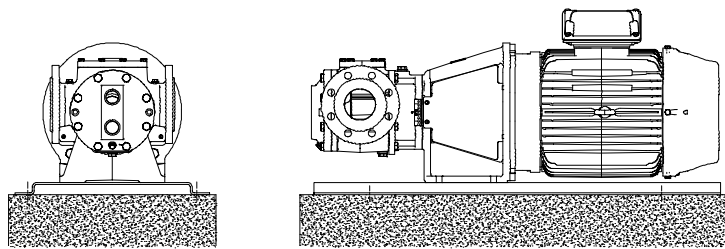

3.17.9.3 Variators, Motors

Consult the supplier's instruction manual, included with the delivery. Contact the pump supplier if the manual is not included.

3.17.9.4 Electric motor drive

- Before connecting an electric motor to the mains check the current local regulations of your electricity provider as well as the EN 60204-1 standard.
- Leave the connecting of electric motors to qualified personnel. Take the necessary measures to prevent damage to electrical connections and wiring.

Circuit breaker

For safety work on a pump unit, install a circuit breaker as close as possible to the machine. It also is advisable to place an earth leakage switch. The switching equipment must comply with current regulations, as stipulated by EN 60204-1.

Motor overload protection

To protect the motor against overloads and short-circuits a thermal or thermo-magnetic circuit breaker must be incorporated. Adjust the switch for the nominal current absorbed by the motor.

Connection

- Do not use a star-delta circuit with electric motors due to the required high starting torque.
- For single-phase alternating current, use motors with a "reinforced" starting torque.
- Ensure a sufficiently high starting torque for frequency-controlled motors and adequate cooling of the motor at low speeds. If necessary, install a motor with forced ventilation.



Electrical equipment, terminals and components of control systems may still carry live current when at rest. Contact with these may be fatal, resulting in serious injury or cause irreparable material damage.

Line	Motor	
U (volt)	230/400 V	400 V
3 x 230 V	delta	–
3 x 400 V	star	delta

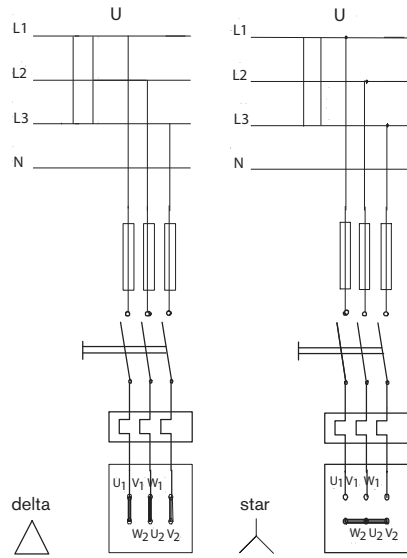

3.18 Instructions for start-up

3.18.1 General

The pump can be put into service when all arrangements described in chapter 3.17 Installation have been made.

- **Prior to commissioning, responsible operators have to be fully informed on proper operation of the pump/pump unit and the safety instructions. This instruction manual must at all times be available to the personnel.**
- **Prior to commissioning, the pump/pump unit must be checked for visible damage. Damage or unexpected changes must be reported immediately to the plant operator.**

3.18.2 Cleaning the pump

There may be residual mineral oil inside the pump deriving from the pump testing and the initially lubricating of the bearing bushes. If these products are not acceptable for the pumped liquid, the pump should be cleaned thoroughly. Proceed as described in section 3.20.2.8 Draining of fluid.

Remark: *pumps made for food applications are preserved with a food grade oil. The oil used is a NSF H3 approved oil (soluble). Nevertheless the oil is NSF H3 approved, the pump should be cleaned thoroughly before the initial start-up.*

3.18.2.1 Cleaning suction line

When the TG BLOC pump is put into service for the first time, suction line must be cleaned thoroughly.

Do not use the pump to flush the system. The TG BLOC pump is not meant to pump low viscosity liquids with impurities.

3.18.3 Venting and filling

To operate properly the pump should be vented and filled with the liquid to be pumped before the initial start-up:

- Unscrew the filling plug Bb and Be. Fill up the pump with the liquid to be pumped. *At the same time the pump will be vented.*
- Tighten the filling plugs.
- When the TG BLOC pump is brought into service for the first time or in case new gaskets are mounted, bolts that compress gaskets must after 3 - 4 days be tightened again (for tightening torques see section 3.20.3.1).

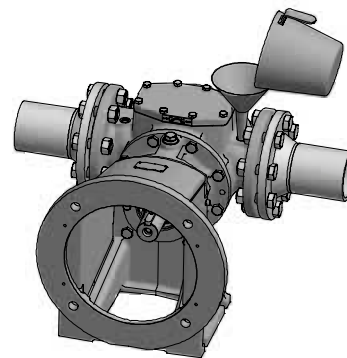
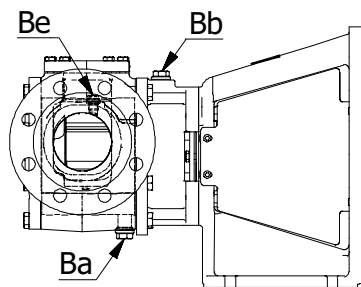

Filling up the pump

3.18.4 Checklist – Initial start-up

After thorough servicing or when the pump is to be put into service for the first time (initial start-up) the following checklist must be observed:

Supply and discharge line

- Suction and discharge pipes are cleaned.
- Suction and discharge pipes are checked for leaks.
- Suction pipe is protected properly to prevent the ingress of foreign bodies.

Characteristics

- The characteristics of the pump unit and safety relief valve to be checked (pumptype – see name plate, RPM, working pressure, effective power, working temperature, direction of rotation, NPSHr etc.).

Electrical installation

- Electrical installation complies with local regulations
- Motor voltage corresponds with mains voltage. Check terminal board.
- Make sure that the starting torque is sufficiently high (no star/delta starting will be used).
- Motor protection is adjusted properly.
- Direction of motor rotation corresponds with direction of pump rotation.
- Motor rotation (detached from unit) is checked.

Safety relief valve

- Safety relief valve (on pump or in piping) is installed
- Safety relief valve is positioned correctly. Flow direction of safety relief valve corresponds with suction and discharge lines.
- Make sure a double safety relief valve is installed when the pump has to operate in two directions.
- The set pressure of the safety relief valve is checked (see name plate).

Jackets

- Jackets are installed.
- Maximum pressure and temperature of the heating/cooling media have been checked.
- The appropriate heating media or coolant is installed and connected.
- The installation complies with the safety standards.

Shaft sealing

- Pressure, temperature, nature and connections of flush or quench media has been checked.

Protection



- All guards and safety devices (coupling bush, rotating parts, excessive temperature) are in place and operative.



- In case of pumps that may reach working temperatures of 60°C or more, ensure sufficient safety guards against occasional touching are in place.

3.18.5 Start-up

When the pump is to be put into service the following checklist and procedure must be observed:

- Pump is filled with liquid.
- Pump is sufficiently preheated.
- Suction and discharge valves are fully open.
- Start the pump for a short while and check the direction of rotation of the motor.
- Start the pump and check suction of liquid (suction pressure).
- RPM of the pump is checked.
- Discharge pipe and seal are checked for leaks.
- Proper operation of the pump is verified.

3.18.6 Shut-down

When the pump is to be put out of service the following procedure must be observed:

- Turn the motor off.
- Close all auxiliary service lines (heating/cooling circuit, circuit for flush/quench medium).
- If solidifying of the liquid must be avoided, clean the pump while the product is still fluid.

Also see section 3.20 Maintenance instructions

Note! When the liquid flows back from the discharge pipe to the pump, the pump may rotate in the opposite direction. Closing the discharge line valve during the last rotation cycles can prevent this.

3.18.7 Abnormal operation

Note! In case of abnormal operation or when troubles occur the pump must be taken out of service immediately. Inform all responsible personnel.

- Prior to restarting the pump, determine the reason for the problem and solve the problem.

3.19 Trouble shooting

Symptom	Cause	Remedy			
No flow Pump not priming	Suction lift too high	1	<ul style="list-style-type: none"> ▪ Reduce difference between pump and suction tank level. ▪ Increase suction pipe diameter. ▪ Reduce length and simplify suction pipe (use as few elbows and other fittings as possible). Also see section 3.17 Installation. 		
		2	<ul style="list-style-type: none"> ▪ Repair leak. 		
		3	<ul style="list-style-type: none"> ▪ Increase pump speed and reduce axial clearance (see section 3.20 Maintenance instructions). 		
		Suction strainer or filter clogged	4	<ul style="list-style-type: none"> ▪ Clear suction strainer or filter. 	
		Pump casing incorrectly installed after repair	5	<ul style="list-style-type: none"> ▪ Install pump casing correctly. See section 3.17 Installation. 	
		Wrong direction of rotation of motor	6	<ul style="list-style-type: none"> ▪ For 3-phase drivers change 2 connections. 	
	<ul style="list-style-type: none"> ▪ Change suction and discharge opening. (Attention! Check the location of the safety relief valve). 				
Pump stalls or irregular flow	Liquid level in suction tank falls too low	7	<ul style="list-style-type: none"> ▪ Correct liquid supply ▪ Provide a level switch 		
	Output too high		8	<ul style="list-style-type: none"> ▪ Reduce pump speed/or install a smaller pump. ▪ Install by-pass line with check-valve. 	
	Air sucking	9	<ul style="list-style-type: none"> ▪ Repair leak in suction line. 		
			<ul style="list-style-type: none"> ▪ Check or replace shaft seal. 		
			<ul style="list-style-type: none"> ▪ Check/provide quench on shaft seal. ▪ Connect plug Bb to the pump discharge in order to increase the pressure in the sealing box. 		
	Cavitation	10	<ul style="list-style-type: none"> ▪ Reduce difference between pump and suction tank level. ▪ Increase suction pipe diameter. ▪ Reduce length and simplify suction pipe (use as few elbows and other fittings as possible). Also see chapter 3.17 Installation. 		
<ul style="list-style-type: none"> ▪ Check temperature. 					
Liquid vaporises in pump (e.g. by heating up)	11	<ul style="list-style-type: none"> ▪ Check vapour pressure of liquid. 			
		<ul style="list-style-type: none"> ▪ Reduce pump speed. If necessary install a larger pump. 			
Not enough capacity	Pump speed too low	12	<ul style="list-style-type: none"> ▪ Increase pump speed. Attention! Do not exceed maximum speed and check NPSHr. 		
	Air sucking	13	<ul style="list-style-type: none"> ▪ Repair leak in suction line. ▪ Check or replace shaft seal. ▪ Check/provide a quench in the shaft seal. ▪ Connect plug Bb to the pump discharge in order to increase the pressure in the sealing box. 		
			Cavitation	14	<ul style="list-style-type: none"> ▪ Reduce difference between pump and suction tank level. ▪ Increase suction pipe diameter. ▪ Reduce length and simplify suction pipe (use as few elbows and other fittings as possible). Also see section 3.17 Installation.
					<ul style="list-style-type: none"> ▪ Check discharge pipe. ▪ Increase pipe diameter. ▪ Reduce working pressure. ▪ Check accessories (filter, heat exchanger, etc.).
	Back pressure too high	15	<ul style="list-style-type: none"> ▪ Check discharge pipe. ▪ Increase pipe diameter. ▪ Reduce working pressure. ▪ Check accessories (filter, heat exchanger, etc.). 		
	Safety relief valve set too low	16	<ul style="list-style-type: none"> ▪ Correct pressure setting. 		

Symptom	Cause	Remedy	
Not enough capacity	Viscosity too low	17 <ul style="list-style-type: none"> Increase pump speed. Attention! Do not exceed maximum speed and check NPSHr. If necessary, install a larger pump. If pump is heated by means of heating jackets or electrical heating, reduce the heating input. 	
		18 <ul style="list-style-type: none"> Check axial clearance and correct. See section 3.20 Maintenance instructions. 	
	Gases come free	19 <ul style="list-style-type: none"> Increase pump speed. Attention! Do not exceed maximum speed and check NPSHr. Install a larger pump 	
Pump too noisy	Pump speed too high	20 <ul style="list-style-type: none"> Reduce pump speed. If necessary, install a larger pump. 	
	Cavitation	21 <ul style="list-style-type: none"> Reduce difference between pump and suction tank level. Increase suction pipe diameter. Reduce length and simplify suction pipe (use as few elbows and other fittings as possible). Also see section 3.17 Installation. 	
		22 <ul style="list-style-type: none"> Increase pipe diameter. Reduce working pressure. Check accessories (filter, heat exchanger, etc.). 	
	Vibration of pipings	23 <ul style="list-style-type: none"> Make pipework better. 	
	Ball bearings damaged or worn	24 <ul style="list-style-type: none"> Replace ball bearings. 	
Pump consumes too much power or becomes hot	Pump speed too high	25 <ul style="list-style-type: none"> Reduce pump speed. If necessary, install a larger pump. 	
	Viscosity too high	26 <ul style="list-style-type: none"> Increase axial clearance. See section 3.20 Maintenance instructions. Heat pump. Reduce pump speed. Increase discharge pipe diameter. 	
Rapid wear		27 <ul style="list-style-type: none"> Increase pipe diameter. Reduce working pressure. Check accessories (filter, heat exchanger, etc.) 	
		Solid matter in liquid	28 <ul style="list-style-type: none"> Filter liquid.
	Pump runs dry	29 <ul style="list-style-type: none"> Correct liquid supply. Provide level switch or dry running protection. Heat up liquid. Stop or reduce air sucking. 	
Motor overloading	Back pressure too high	30 <ul style="list-style-type: none"> Change pump materials or application parameters. 	
		31 <ul style="list-style-type: none"> Increase pipe diameter. Reduce working pressure. Check accessories (filter, heat exchanger, etc.). 	
Pump leak		Viscosity too high	32 <ul style="list-style-type: none"> Increase axial clearance. See section 3.20 Maintenance instructions. Heat pump. Reduce pump speed. Increase discharge pipe diameter.
	33 <ul style="list-style-type: none"> Replace mechanical seal. 		
	Rapid wear of the mechanical seal		34 <ul style="list-style-type: none"> Heat the pump.
			35 <ul style="list-style-type: none"> Fill pump with liquid Check position of relief valve or top cover.
Rapid wear of the mechanical seal	Temperature too high	36 <ul style="list-style-type: none"> Reduce temperature. Install suitable mechanical seal. 	
		37 <ul style="list-style-type: none"> Reduce suction line. Provide dry running protection. Check maximum allowable dry running speed for the mechanical seal. 	
	Liquid is abrasive	38 <ul style="list-style-type: none"> Filter or neutralise liquid. 	

Note! If symptoms persist, the pump must be taken out of service immediately. Contact your local supplier.

3.19.1 Instructions for re-using and disposal

3.19.1.1 Re-use

Re-use or putting the pump out of service should only be undertaken after complete draining and cleaning of the internal parts.



Note! *When doing so, observe adequate safety regulations and take environmental protection measures.*

Liquids should be drained and following local safety regulations the correct personal equipment should be used.

3.19.1.2 Disposal

Disposal of the pump should only be done after it has been completely drained. Proceed according to local regulations.

When applicable please disassemble the product and recycle the part's material.

3.20 Maintenance instructions

3.20.1 General

This chapter only describes operations that can be performed on-site for normal maintenance. For maintenance and repair requiring a workshop contact your local supplier.

- Insufficient, wrong and/or irregular maintenance can lead to malfunctions in the pump, high repair costs and long-term inoperability. Therefore, you should carefully follow the guidelines given in this chapter.

During maintenance operations on the pump due to inspections, preventive maintenance or removal from the installation, always follow the prescribed procedures.



Non-compliance with these instructions or warnings may be dangerous for the user and/or seriously damage the pump/pump group.



- Maintenance operations should be performed by qualified personnel only. Always wear the required safety clothing, providing protection against high temperatures and harmful and/or corrosive fluids. Make sure that the personnel read the entire instruction manual and, in particular, indicate those sections concerning the work at hand.



- SPX FLOW is not responsible for accidents and damage caused by non-compliance with the guidelines.

3.20.2 Preparation

3.20.2.1 Surroundings (on site)

Because certain parts have very small tolerances and/or are vulnerable, a clean work environment must be created during on-site maintenance.

3.20.2.2 Tools

For maintenance and repairs use only technically appropriate tools that are in good condition. Handle them correctly.

3.20.2.3 Shut-down

Before commencing the maintenance and inspection activities the pump must be taken out of service. The pump/pump unit must be fully depressurized. If the pumped fluid permits, let the pump cool down to the surrounding temperature.

3.20.2.4 Motor safety

Take appropriate steps to prevent the motor from starting while you are still working on the pump. This is particularly important for electric motors that are started from a distance. Follow the below described procedure:

- Set the circuit breaker at the pump to "off".
- Turn the pump off at the control box.
- Secure the control box or place a warning sign on the control box.
- Remove the fuses and take them with you to the place of work.
- Do not remove the protective guard around the coupling bush until the pump has come to a complete standstill.

3.20.2.5 Conservation

If the pump is not to be used for longer periods:

- First drain the pump.
- Then treat the internal parts with VG46 mineral oil or other preserving liquid. (e.g. food grade oil for food applications).
- The pump must be operated briefly once a week or alternatively the shaft must be turned a full turn once a week. This ensures proper circulation of the protective oil.

3.20.2.6 External cleaning

- Keep the surface of the pump as clean as possible. This simplifies inspection, the attached markings remain visible.
- Make sure cleaning products do not enter the ball bearing space. Cover all parts that must not come into contact with fluids. In case of sealed bearings, cleaning products must not attack rubber gaskets. Never spray the hot parts of a pump with water, as certain components may crack due to the sudden cooling and the fluid being pumped may spray into the environment.

3.20.2.7 Electrical installation

- Maintenance operations on the electric installation may be performed only by trained and qualified personnel and after disconnecting the electric power supply. Carefully follow the national safety regulations.
Respect the above-mentioned regulations if performing work while the power supply is still connected.
- Check if electrical devices to be cleaned have a sufficient degree of protection (e.g. IP54 means protection against dust and splashing water but not against water jets). See EN 60529. Choose an appropriate method for cleaning the electrical devices.
- Replace defective fuses only with original fuses of the prescribed capacity.
- After each maintenance session check the components of the electrical installation for visible damage and repair them if necessary.

3.20.2.8 Draining of fluid



- Close off the pressure and suction lines as close as possible to the pump.
- If the fluid being pumped does not solidify, let the pump cool down to the ambient temperature before drainage.
- For fluids that solidify or become very viscous at ambient temperature, it is best to empty the pump immediately after shutting down by separating it from the piping. Always wear safety goggles and gloves.
- Protect yourself with a protective cap. The fluid may spray out of the pump.
- Open the venting plugs Be and Bb.
- If no drain line is provided, take precautions so that the liquid is not contaminating the environment.
- Open the drain plug Ba at the bottom of the pump housing.
- Let drain the liquid by gravity.
- Purge pump spaces with flush media or cleaning liquid by connecting a purge system to the following inlet openings:
 - Ba, Be: the displacement part
 - Ba, Bb: space behind rotor
- Re-assemble the plugs and close the valves, if any.

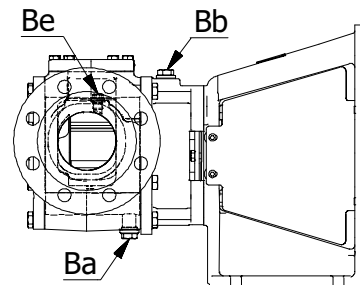

3.20.2.9 Fluid circuits

- Depressurize the jackets and the retaining fluid circuits.
- Uncouple the connections to the jackets and to the circulating or flush/quench media circuits.
- If necessary, clean the jackets and the circuits with compressed air.
- Avoid any leakage of fluid or thermal oil into the environment.

3.20.3 Specific components

3.20.3.1 Nuts and bolts

Nuts and bolts showing damage or parts with defective threading must be removed and replaced with parts belonging to the same fixation class as soon as possible.

- Preferably use a torque wrench for tightening.
- For the tightening torques, see table below.

Bolt	Ma (Nm) 8.8 / A4	Plug with edge and flat seal	Ma (Nm)
M6	10	G 1/4	20
M8	25	G 1/2	50
M10	51	G 3/4	80
M12	87	G 1	140
M16	215	G 1 1/4	250
M20	430		
M24	740		
M30	1500		

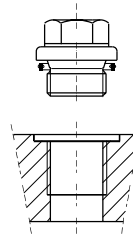

Plug with edge and elastic washer

3.20.3.2 Plastic or rubber components

- Do not expose components made of rubber or plastic (cables, hoses, seals) to the effects of oils, solvents, cleaning agents or other chemicals unless they are suitable.
- These components must be replaced if they show signs of expansion, shrinkage, hardening or other damage.

3.20.3.3 Flat gaskets

- Never re-use flat gaskets.
- Always replace the flat gaskets and elastic rings under the plugs with genuine spares from SPX FLOW.

3.20.3.4 Filter or suction strainer

Any filters or suction strainers at the bottom of the suction line must be cleaned regularly.

Note! A clogged filter in the suction piping may result in insufficient suction pressure at the inlet. Clogged filter in the discharge line may result in higher discharge pressure.

3.20.3.5 Anti-friction bearings

TG BLOC pumps are equipped with 2RS ball bearings which is grease packed for life. It does not require periodically greasing.

3.20.3.6 Sleeve bearings

We recommend checking the pump regularly for wear on the gear wheels and sleeve bearings to avoid excessive wear of other parts.

- A quick check can be done by using the front pull-out and back pull-out system. See table for maximum allowable radial clearance of the sleeve bearings.
- For replacement of the sleeve bearings contact your local supplier.

TG BLOC pump size	Maximum allowed radial clearances
15-50 to 23-65	0.15 mm
58-80 to 86-100	0.25 mm

3.20.3.7 Shaft seal – Mechanical seal

If the mechanical seal leaks excessively, it must be replaced with one of the same type.

Note! The materials of the mechanical seal are selected strictly in accordance with the nature of the pumped liquid and the operating conditions. Thus the pump must only handle the liquid for which it was purchased. If the liquid or operating conditions are changed, a mechanical seal suitable for the new operating conditions must be fitted.

3.20.4 Front pull-out

The TG BLOC pumps also have a front pull-out system.

To remove liquid residues or to check the idler bearing for wear, the pump cover can be pulled out from the pump housing without disconnecting suction and discharge pipes.

See chapters 4.0 Disassembly/Assembly and section 6.5 Weights.

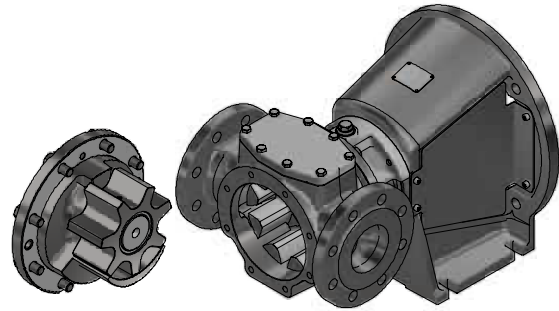

3.20.5 Back pull-out

To flush the pump or to check the sleeve bearing for wear the lantern piece with intermediate casing, shaft and rotor can be easily pulled out backwards without disconnecting the suction and discharge pipes.

See chapters 4.0 Disassembly/Assembly and section 6.6 Weights.

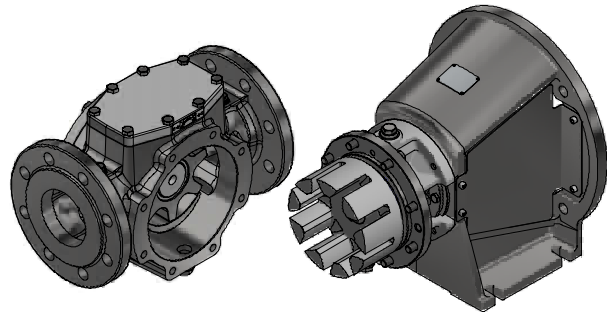

3.20.6 Clearance adjustment

The TG BLOC pumps are delivered with the correct axial clearance setting. In some cases, however, the axial clearance needs to be adjusted:

- When uniform rotor and idler wear need to be compensated.
- When the flow is too low pumping low viscous liquids and the slip has to be reduced.
- When the liquid is more viscous than expected, the friction inside the pump can be reduced by increasing the axial clearance.

Nominal axial clearance	
TG BLOC pump size	(S _{ax}) [mm]
15-50 to 23-65	0.10 – 0.15
58-80 to 86-100	0.15 – 0.20

Proceed as follows to set the axial clearance:

1. Disassemble motor from lantern piece
2. Loosen the tap bolts (2290a) on the pump casing side
3. Tighten the tap bolts (2290b) on the motor side until the pump shaft with rotor and bearing is pushed completely against the pump cover, the axial clearance "S_{ax}" is then 0.
4. Measure the distance "A" between coupling bush (6010) and lantern piece flange (1400).
5. Loosen the tap bolts (2290b) and fix the ball bearing by tightening the tap bolts (2290a) equally thus pressing shaft with rotor and ball bearing backwards.
6. Measure again the distance "A" between coupling bush (6010) and lantern piece flange (1400), the difference between the measured distances is the new axial clearance "S_{ax}".
 - If the axial clearance is too small, repeat step 5 & 6.
 - If the axial clearance is too big, loosen the tap bolts (2290a) again and tighten the tap bolt (2290b) and then repeat step 6.

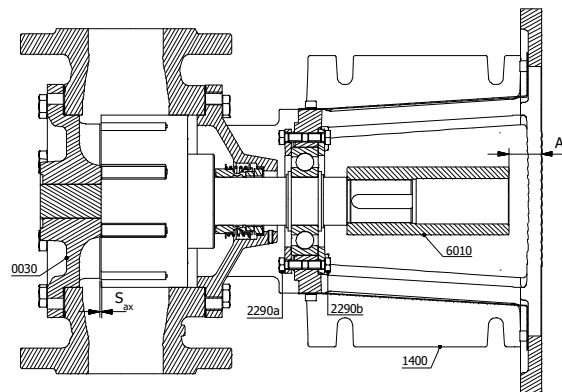

Another method to adjust axial clearance by using a magnet stand and a dial gauge.

1. Disassemble motor from lantern piece
2. Loosen the tap bolts (2290a) on the pump casing side
3. Tighten the tap bolts (2290b) on the motor side until the pump shaft with rotor and bearing is pushed completely against the pump cover, the axial clearance " S_{ax} " is then 0.
4. Place the magnet stand on lantern piece and the dial gauge plunger on coupling bush and initialise the dial gauge.
5. Loosen the tap bolts (2290b) and tighten the tap bolts (2290a) equally until the needle of the dial gauge registers a little more (0.02mm) than the desired clearance.
6. Fix the ball bearing by tightening the tab bolts (2290b) until the needle of the dial gauge falls back on to the desired clearance.

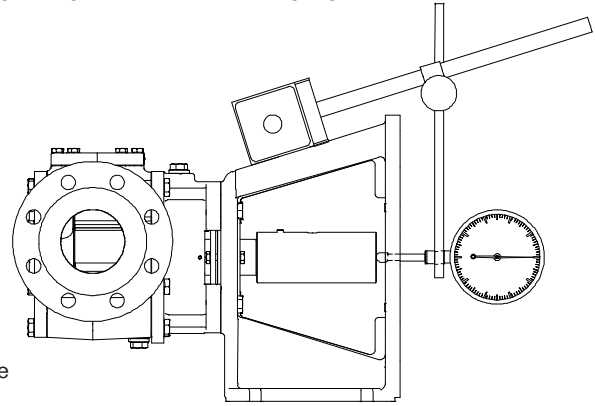

3.20.7 Designation of threaded connections.

To make clear what sealing type of threaded connection is provided we denominate them according to standards ISO 7/1 and ISO 228/1 as follows.

3.20.7.1 Threaded connection Rp (example Rp 1/2)

If no flattened sealing face is provided we call the connection Rp accordingly ISO 7/1. This connection has to be sealed in the thread. The plugs or pipe connections must be provided with conical thread according to ISO 7/1 external thread (example ISO 7/1 – R1/2).

Conical plug
ISO 7/1 - R1/2

Conical pipe end
ISO 7/1 - R1/2

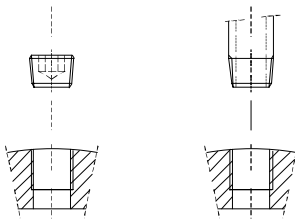

ISO 7/1	Type	Symbol	Example
Internal thread	Cylindrical (parallel)	Rp	ISO 7/1 – Rp 1/2
External thread	Always conical (tapered)	R	ISO 7/1 – R 1/2

3.20.7.2 Threaded connection G (example G 1/2)

If the threaded connection is provided of a flattened sealing face we call it G according ISO 228/1. This connection can be sealed by a gasket. The plugs or pipe connections must be provided with a sealing collar and cylindrical external thread according to ISO 228/1 (Example ISO 228/1 - G1/2).

Plugs or pipe connections provided with conical thread according to ISO 7/1 external thread (example ISO 7/1 – R1/2) can also be used.

Plug with collar
ISO 228/1 - G1/2

Conical pipe end
ISO 7/1 - R1/2

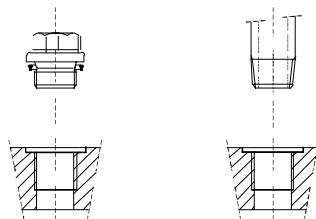

ISO 228/1	Clearance class	Symbol	Example
Internal thread	Only one class	G	ISO 228/1 – G 1/2
External thread	Class A (standard)	G	ISO 228/1 – G 1/2
	Class B (extra clearance)	G...B	ISO 228/1 – G 1/2 B
ISO 7/1	Type	Symbol	Example
External thread	Always conical (tapered)	R	ISO 7/1 – R 1/2

4.0 Instructions for assembly and disassembly

4.1 General

Insufficient or wrong assembly and disassembly can lead to the pump malfunctioning, high repair costs and long-term inoperability. Contact your local supplier for information.

Disassembly and assembly may only be carried out by trained personnel. Such personnel should be familiar with the pump and follow the instructions below.



Non-compliance with the instructions or neglecting warnings can damage the user or lead to severe damage to pump and/or pump unit. SPX FLOW is not liable for accidents and damage resulting from such neglect.

4.2 Tools

- Set of nut spanners Width 8 - width 30
- Set of hexagonal spanners Width 2 - width 14
- Screw driver
- Anti-recoil hammer Rubber, plastic, lead
- Carton, paper, shammy
- Coupling bush extractor
- Ball bearing extractor
- Assembly oil For example Shell ONDINA 15
Esso BAYOL 35
or lubricant For example OKS 477
- Loctite 241 Max. temperature = 150°C
- Loctite 648 Heat resistant type
- Measuring tool for adjustment of the axial clearance Also see section 3.20.6
- Measuring tool to measure the height of the adjusting screw of the safety valve Also see section 3.16.3

4.3 Preparation

All activities described in this chapter need to be executed in a workshop suitable for repairs or a mobile workshop, arranged in the working environment.

Always work in a clean surrounding. Keep all sensitive parts, such as seals, bearings, mechanical shaft seals, etc. in their packaging as long as possible.

Always follow the instructions in section 3.20 with regard to:

- taking the pump out of service
- back pull-out and front pull-out
- disassembly of the pump from the system
- adjusting axial clearance
- adjusting safety relief valve

4.4 After disassembly

- After each disassembly carefully clean the parts and check them for damage, if any. Replace all damaged parts.
- Replace damaged parts with original components.
- When assembling, use new graphite gaskets. Never use flat gaskets that have been used previously.

4.5 Coupling bush

4.5.1 General

The coupling bush has a slide fitting on the pump shaft, Hammering or hard pushing can damage the ball bearing and disturb the axial clearance setting.

4.5.2 TG BLOC15-50 to TG BLOC86-100 coupling bush assembly

1. Screw a stud (or some other special tool) in the tapped hole of the pump shaft.
2. Place the coupling bush on the shaft end with the aid of a nut and a great washer, you can also heat up the coupling bush (+/- 80°C with water or oil) for easy fitting.

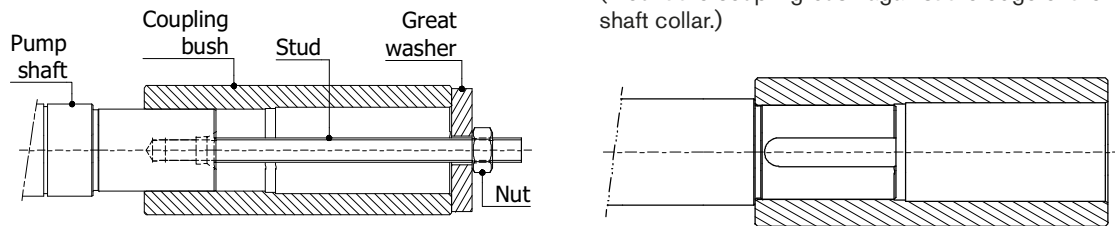

4.6 Anti-friction bearings

4.6.1 General

- Never re-use a disassembled bearing or a disassembled lock plate!
- For disassembly and assembly of the bearing (and coupling), use correct tools in order to inspect the pump without any shock loads. Shocks can damage the crisp material of bush bearings and mechanical seal.
- The anti-friction bearing has an interference fit on the pump shaft and a clearance fit in the lantern piece.
- The anti-friction bearing can easily be mounted when heated to 80°C so that it slides on the pump shaft.
- Always push on the inner ring of the bearing. Pushing on the outer ring may damage the rolling parts between rotor and shaft.
- Support pump shaft at rotor side, not the rotor! Axial force on rotor - pump shaft may damage the shrink connection.
- Anti-friction bearings type 2RS are sealed and greased for life.

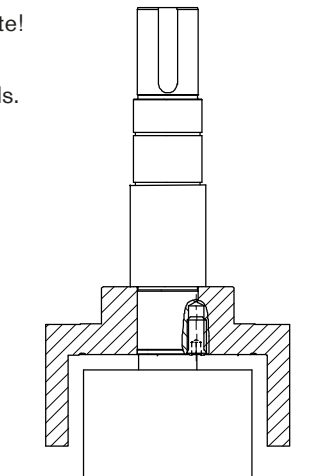

4.6.2 TG BLOC15-50 to TG BLOC86-100 disassembly

1. Remove hex nuts (6040) and bolts (6030) and disassemble the flanged motor.
2. Remove tap bolts (1610) from lantern piece (1400) and remove the protection plates (1600).
3. Release set screw (6020) on the coupling bush (6010) and pull off the coupling bush (6010) from the shaft (0702) by use of appropriate extractor.
4. Remove the shaft key (1570).
5. Loosen the tab bolts (2290) and remove the bearing cover (1430).
6. Loosen the tap bolt (1410) and disassemble the lantern piece (1400).
7. Remove outer circlip (1450) and support ring (1460).
8. Push the second bearing cover (1430) towards the pump and disassemble the bearing (1440) with the use of appropriate extractor.
9. Remove the second support ring (1460) and inner circlip (1450 - in case of TG BLOC 58-80/86-100) if necessary.

4.6.3 TG BLOC15-50 to TG BLOC86-100 assembly

1. First fix the bearing cover (1430) on the lantern piece (1400) by fixing the tap bolts (2290) of pump side; do not tighten them completely.
2. Assemble the lantern piece (1400) by fixing the tap bolts (1410)
3. Fix the inner circlip (1450 - in case of TG BLOC 58-80/86-100) and place the support ring (1460) on the pump shaft (0702).
4. Assemble a new ball bearing (1440) on the shaft (0702) with the use of proper tooling and push it against the support ring (1460).
5. Place the second support ring (1460) and the outer circlip (1450) on the pump shaft.
6. Fix the bearing cover (1430) and tighten the tap bolts (2290).
7. Place the key (1570) and mount the coupling bush (6010) (see section 4.5.2) on the pump shaft (0702) and fix the set screw (6020).
8. Adjust the axial clearance (see section 3.20.6).
9. Reassemble the protection plates (1600) by fixing the tap bolts (1610).

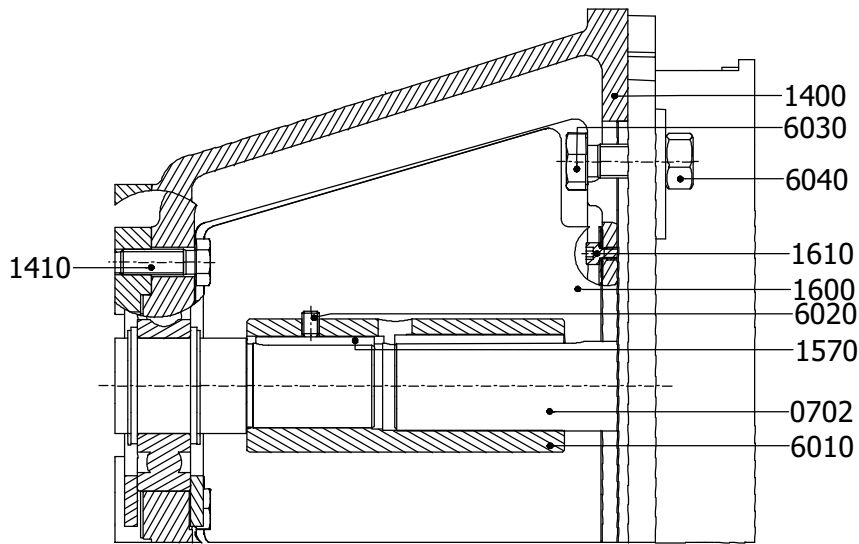

DETAIL B: 15-50 / 23-65

DETAIL B: 58-80 / 86-100

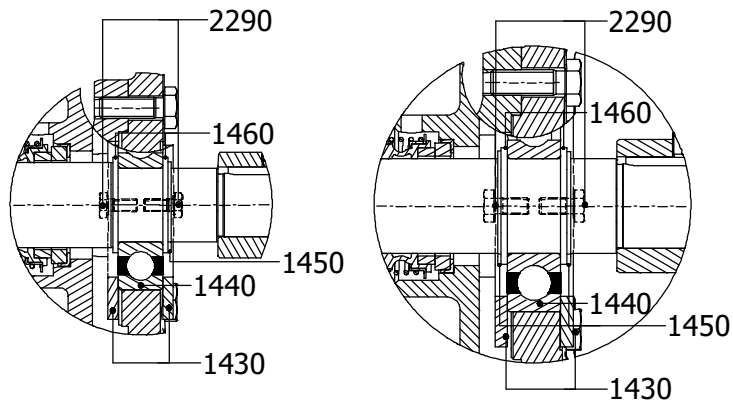

*Disassembly and assembly of rolling bearing
TG BLOC15-50 to 86-100*

4.7 Mechanical seal

Guidelines for assembly and adjustment of the mechanical seal – pump range TG BLOC.

4.7.1 General

- All personnel responsible for maintenance, inspection and assembly must be adequately qualified.
- Use specific instructions coming with the mechanical seal which is to be assembled/adjusted.
- The assembling and adjusting of mechanical seals must be performed in a clean workshop.
- Use technically appropriate tools that are in good condition. Handle them correctly.

4.7.2 Preparation

Check if the mechanical seal to be mounted has the appropriate size and construction and verify if it can be assembled. The short EN12756 (DIN24960) single mechanical seal can be built in. The mechanical seal is set against the rotor shoulder.

TG BLOC pump size	15-50 23-65	58-80 86-100
Shaft diameter	40	45
Short EN12756 (DIN24960)	KU040	KU045
L1K (short KU)	45	45

Dimensions in mm

4.7.3 Special tools

- Conical protection bush (9010)
- Shabby

4.7.4 General instructions during assembly

- Do not touch the mechanical seal faces with hand or fingers. Fingerprints can make the mechanical seal untight. Clean the seal faces if necessary. Use a shabby.
- If the mechanical seal faces are made of non self-lubricating material, it is recommended to lubricate the faces a little with the pumped liquid or with thin oil. **Do not use grease!**
- Lubricate the O-rings when assembling. Take care of compliance of the lubricant and the rubber material. **Never use mineral oil using EP rubber O-rings.**
- When fitting PTFE sealings the shaft must be very smooth. Assembly of solid PTFE sealings can be facilitated by heating the stationary ring in water at 100°C during 15 minutes. Pre-assemble the rotary ring on a dummy shaft and heat both ring and shaft in water at 100°C during 15 minutes. Then let everything cool off. To be tight, PTFE seals must rest for approx. 2 hours so that the O-ring remains in its new shape.
- In cases where the mechanical seal is provided with fixing screws to fix the rotating part on the shaft, it is recommended to screw out the fixing screws, degrease both holes and screws and lock them with Loctite (usual type 241 or heat-resistant type 648).

4.7.5 Assembly of the rotating part

- Lubricate the shaft a little with a lubricant.

Attention for EP rubber: do not use mineral oil!

- Protect the sharp edges of the shaft with tape or another protecting tool.
- Use a conical assembling bush (9010) on the shaft step (see figure).
- Push the rotating parts against the rotor shoulder.
- Provide the set screws with a drop heat-resistant Loctite and fit the set screws in the rotating part. Tighten the screws.

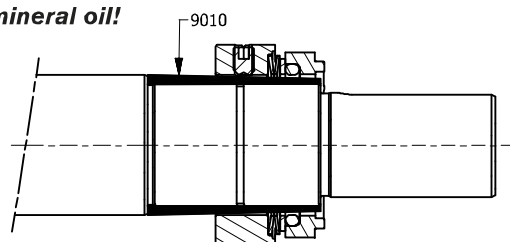

4.7.6 Assembly of the stationary seat

- Fit the stationary seat(s) into the intermediate casing.
- Use appropriate tools to push the seat perpendicularly in its housing.
- Protect the seat face with a piece of paper or hardboard and lubricate the rubber sealing elements with a lubricant. This will facilitate the assembly.
Attention! Do not use mineral oil for EP rubber.
- Check the perpendicularity of the seat face to the shaft rotating axis after assembling.

4.8 Pumps

4.8.1 General

- Always replace damaged parts with original parts.
- At every disassembly new graphite gaskets must be used. Never re-use gaskets.

4.8.2 TG BLOC15-50 to TG BLOC86-100

Dissassembly

1. Remove lantern piece and ball bearing as described in bearing disassembly, section 4.6.2.
2. Remove pump cover (4000) by loosening bolts (0040) and remove idler (0600).
3. Detach intermediate casing (0020) by loosening the tap bolts (1200) and remove the intermediate casing.
4. Push the shaft with rotor (0700) from back and remove it.

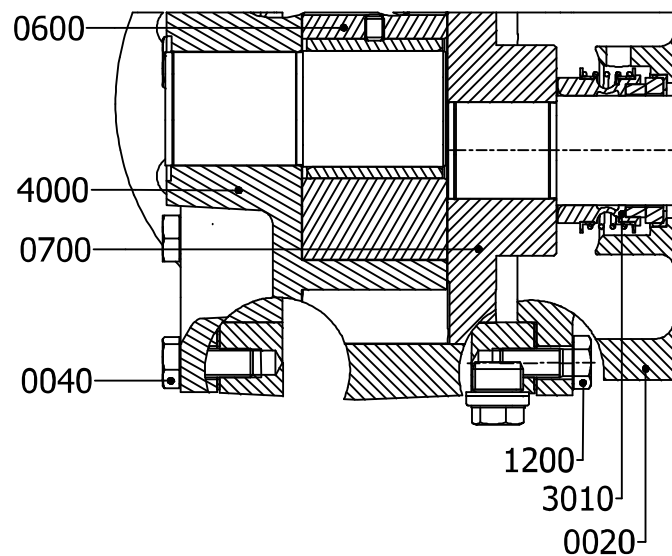

Assembly

1. First assemble seal (3010) see sections 4.7.5 and 4.7.6.
2. Fit the intermediate casing (0020) and tighten the tap bolts (1200).

4.9 Relief valve

- The relief valve may not be disassembled before the spring has been released completely
- **Before releasing the spring, measure the position of the adjusting bolt, so that the spring afterwards can be adjusted to its original opening pressure**

4.9.1 Disassembly

- Undo the screws (7310) and the cover (7050).
- Measure and record the exact position of the adjusting bolt (7320). (See dimension H).
- Loosen nut (7330) and adjusting screw (7320) until the spring (7150) has been completely released.
- Remove spring casing (7040) by loosening the screws (7300).
- Spring (7150), valve (7010) and valve seat (7110) are now accessible.

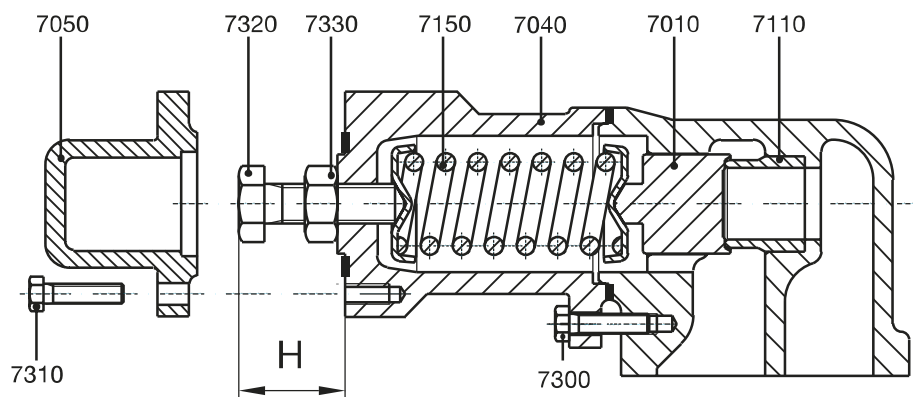

Assembly and disassembly of the safety relief valve

4.9.2 Assembly

- Check the sealing face of both valve seat (7110) and valve (7010).
- In case of a slightly damaged surface, this can be rubbed with an appropriate emery paste. In case of severe damage however, valve seat (pay attention to shrink fit) and valve must be replaced.
- Always mount a correct type of spring with the original dimensions and an appropriate adjusting screw (see section 3.16.3).
- Fit spring casing (7040) and bolts (7300).
- Fit adjusting screw (7320) and nut (7330), screwing the adjusting screw to measured distance H.
- Fix this position by tightening the nut (7330).

Remark: When another type of spring and/or adjusting bolt is mounted, the opening pressure of the relief valve must be adjusted hydraulically.

- Fit cover (7050) and screws (7310).

5.0 Sectional drawings and part lists

How to order spares

When ordering spare parts, please state:

1. Pump type and serial number (see name plate)
2. Position number, quantity and description

Example:

1. Pump type: TG BLOC58-80G2SSG2G1AV
Serial number: 2000-101505
2. Pos 0600, 1, Idler + Bush complete

5.1 TG BLOC15-50 to TG BLOC86-100

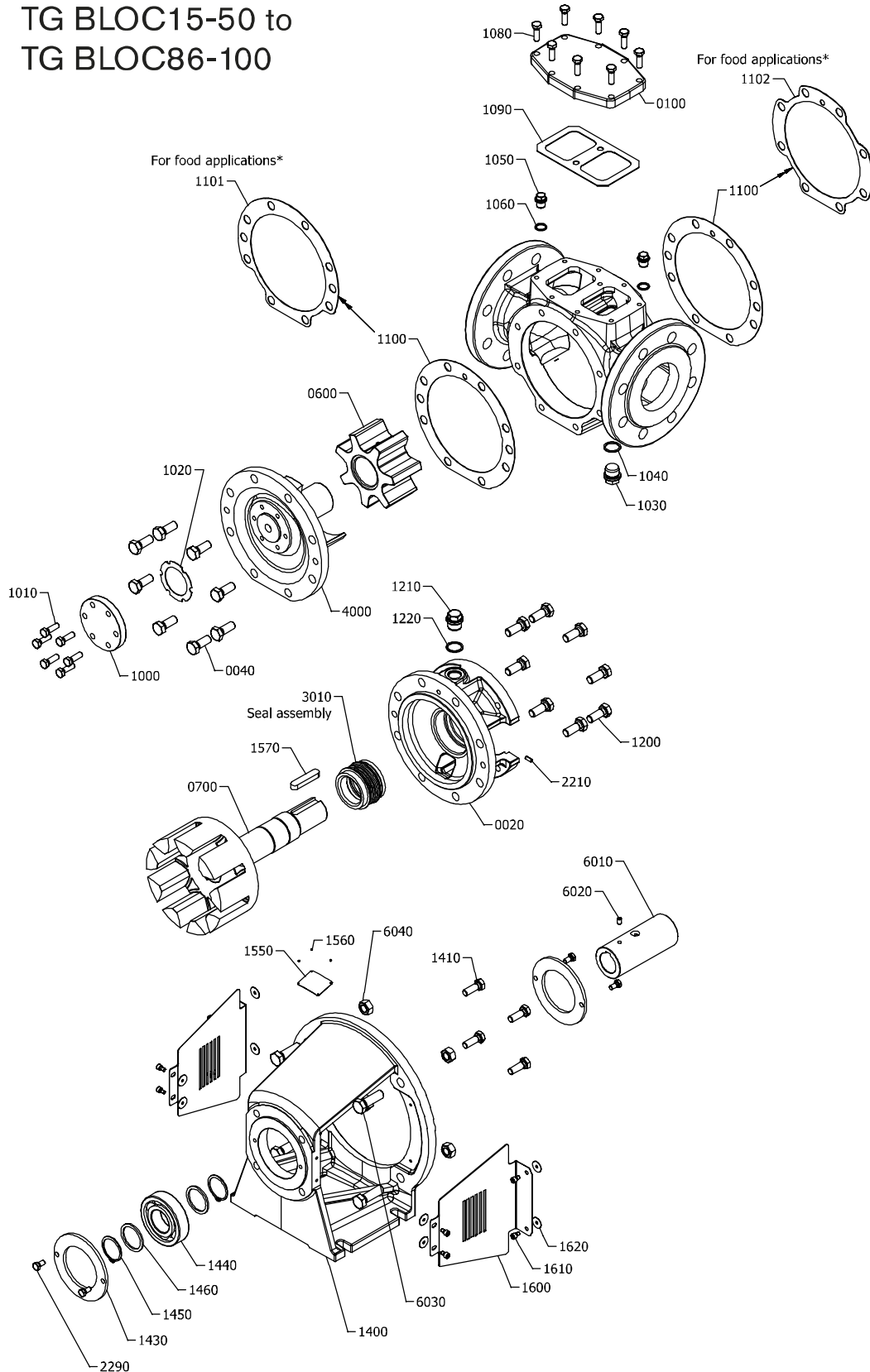

5.2.1 Hydraulic part

Pos.	Description	BLOC15-50	BLOC23-65	BLOC58-80	BLOC86-100	preventive	overhaul
0010	pump casing	1	1	1	1		
0020	intermediate casing	1	1	1	1		
0040	tap bolt	6	6	8	8		
0100	top cover complete	1	1	1	1		
0600	idler + bush, complete	1	1	1	1	x	
0700	rotor + shaft, complete	1	1	1	1	x	
1000	pin cover	1	1	1	1		
1010	tap bolt	6	6	6	6		
1020	gasket	1	1	1	1	x	x
1030	plug	1	1	1	1		
1040	sealing ring	1	1	1	1	x	x
1050	plug	2	2	2	2		
1060	sealing ring	2	2	2	2	x	x
1080	tap bolt	8	8	8	8		
1090	gasket	1	1	1	1	x	x
1100*	gasket	2	2	2	2	x	x
1101*	gasket	1	1	1	1	x	x
1102*	gasket	1	1	1	1	x	x
1200	screw	6	6	8	8		
1210	plug	1	1	1	1		
1220	sealing ring	1	1	1	1	x	x
1230	plug	1	1	1	1		
1570	key	1	1	1	1	x	x
4000	pump cover + idler pin, complete	1	1	1	1	x	

* pos. 1100 applies for non-food pumps (2x per pump)

pos. 1101 and 1102 applies for food pumps (1 of each per pump)

5.2.2 Bearing lantern

Pos.	Description	BLOC15-50	BLOC23-65	BLOC58-80	BLOC86-100	preventive	overhaul
1400	bearing lantern	1	1	1	1		
1410	tap bolt	4	4	4	4		
1430	bearing cover	2	2	2	2		
1440	ball bearing	1	1	1	1	x	x
1450	circlip	1	1	2	2		x
1460	support ring	2	2	2	2		
1550	name plate	1	1	1	1		
1560	rivet	4	4	4	4		
1600	protection plate	2	2	2	2		
1610	tap bolt	8	8	8	8		
1620	washer	8	8	8	8		
2290	tap bolt	4	4	4	4		
6010	coupling bush	1	1	1	1		
6020	set screw	1	1	1	1		
6030	tap bolt	4	4	4*	4*		
6040	nut	4	4	4*	4*		

* for BLOC 58-80/86-100 with IEC225 quantity of pos.6030 and 6040 will be 8

5.2.3 Jacket

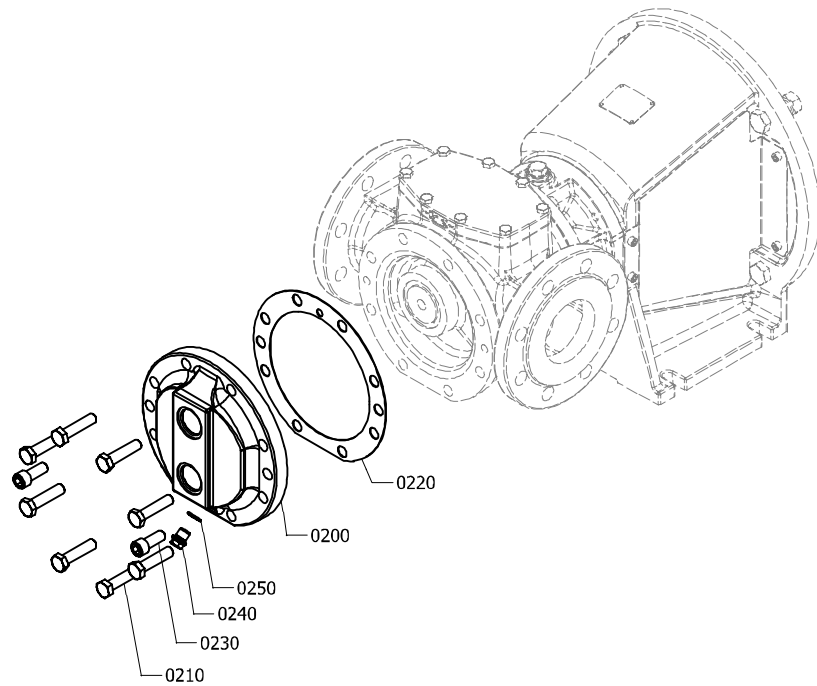

Pos.	Description	BLOC15-50	BLOC23-65	BLOC58-80	BLOC86-100	preventive	overhaul
0200	jacket cover	1	1	1	1		
0210	tap bolt	6	6	8	8		
0220	gasket	1	1	1	1	x	x
0230	Allen screw	2	2	2	2		
0240*	plug	1	1	1	1		
0250*	sealing ring	1	1	1	1	x	x

* 0240 and 0250 not applicable for 15-50/23-65 cast iron version

5.2.4 Single mechanical seal

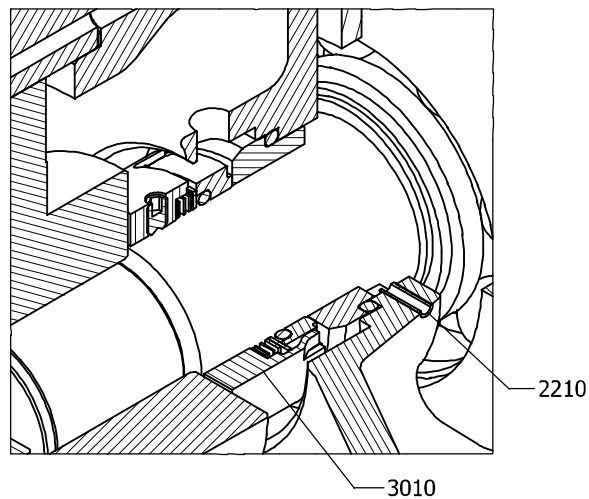

Pos.	Description	BLOC15-50	BLOC23-65	BLOC58-80	BLOC86-100	preventive	overhaul
2210	pin	1	1	1	1		
3010	mechanical seal	1	1	1	1	x	x

	MOTOR IEC-CEI	fa	fb	fc	n x fd	fe	mb	sp	ta	va	vb	vc	vd	ve	vf	vg	vh	za	zc	sc-max
TG BLOC15-50	100L-B14-F165	130	165	220	4 x 12	13	80	167	604	100	170	200	12	85	13	6	150	125	287	285
	112M-B14-F165	130	165	220	4 x 12	13	80	167	621	100	170	200	12	85	13	6	150	125	287	310
	132S-B5-F265	230	265	300	4 x 14	16	100	168	686	110	200	235	14	100	15	7	175	163	313	380
	132M-B5-F265	230	265	300	4 x 14	16	100	168	724	110	200	235	14	100	15	7	175	163	313	380
	160M-B5-F300	250	300	356	4 x 18	19	130	170	841	140	230	270	14	140	16	9	210	193	352	447
	160L-B5-F300	250	300	356	4 x 18	19	130	170	885	140	230	270	14	140	16	9	210	193	352	447
TG BLOC23-65	100L-B14-F165	130	165	220	4 x 12	13	80	167	604	100	170	200	12	85	13	6	150	125	287	285
	112M-B14-F165	130	165	220	4 x 12	13	80	167	621	100	170	200	12	85	13	6	150	125	287	310
	132S-B5-F265	230	265	300	4 x 14	16	100	168	686	110	200	235	14	100	15	7	175	163	313	380
	132M-B5-F265	230	265	300	4 x 14	16	100	168	724	110	200	235	14	100	15	7	175	163	313	380
	160M-B5-F300	250	300	356	4 x 18	19	130	170	841	140	230	270	14	140	16	9	210	193	352	447
	160L-B5-F300	250	300	356	4 x 18	19	130	170	885	140	230	270	14	140	16	9	210	193	352	447
TG BLOC58-80	180M-B5-F300	250	300	356	4 x 18	19	130	170	907	140	230	270	14	140	16	9	210	193	352	460
	160M-B5-F300	250	300	356	4 x 18	19	130	203	873	140	230	270	14	140	16	9	210	200	385	447
	160L-B5-F300	250	300	356	4 x 18	19	130	203	917	140	230	270	14	140	16	9	210	200	385	447
	180L-B5-F300	250	300	356	4 x 18	19	130	203	977	140	230	270	14	140	16	9	210	200	385	460
	200L-B5-F350	300	350	400	4 x 19	19	130	203	1042	140	270	300	14	140	16	9	210	220	385	520
225-B5-F400	350	400	450	8 x 19	22	160	221	1123	160	290	320	18	140	20	9	240	245	416	610	
TG BLOC86-100	160M-B5-F300	250	300	356	4 x 18	19	130	213	883	140	230	270	14	140	16	9	210	205	395	447
	160L-B5-F300	250	300	356	4 x 18	19	130	213	927	140	230	270	14	140	16	9	210	205	395	447
	180L-B5-F300	250	300	356	4 x 18	19	130	213	987	140	230	270	14	140	16	9	210	205	395	460
	200L-B5-F350	300	350	400	4 x 19	19	130	213	1052	140	270	300	14	140	16	9	210	225	395	520
	225-B5-F400	350	400	450	8 x 19	22	160	231	1133	160	290	320	18	140	20	9	240	250	426	610

6.2 Flange connections

6.2.1 TG BLOC15-50 to 86-100

6.2.1.1 Cast iron

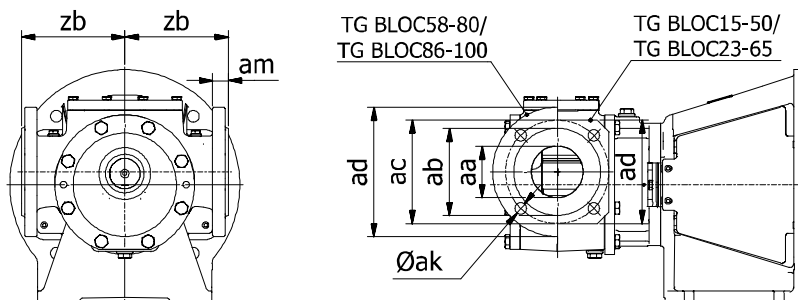

	TG BLOC15-50	TG BLOC23-65	TG BLOC58-80	TG BLOC86-100
aa	50	65	80	100
ab	100	118	135	153
ac PN16	125	145	160	180
ac PN20	120,5	139,5	152,5	190,5
ad	125 *)	145 *)	200	220
ak PN16	4xd18	4xd18	8xd18	8xd18
ak PN20	4xd18	4xd18	4xd18	8xd18
am	21	21	24	25
zb	125	125	160	180

*) Square flanges instead of rounded flanges

6.2.1.2 Stainless steel

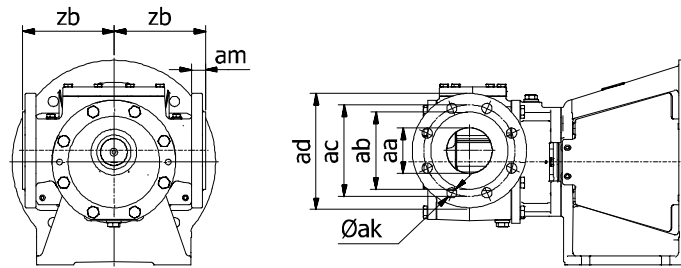

	TG BLOC15-50	TG BLOC23-65	TG BLOC58-80	TG BLOC86-100
aa	50	65	80	100
ab	98	120	133	160
ac PN16	125	145	160	180
ac PN20	120.5	139.5	152.5	190.5
ac PN25	125	145	160	190
ac PN40	125	145	160	190
ac PN50	127	149.5	168	200
ad	165	187	206	238
ak PN16	4xd18	4xd18	8xd18	8xd18
ak PN20	4xd18	4xd18	4xd18	8xd18
ak PN25	4xd18	8xd18	8xd18	8xd22
ak PN40	4xd18	8xd18	8xd18	8xd22
ak PN50	8xd18	8xd22	8xd22	8xd22
am	21	21	24	25
zb	125	125	160	180

6.3 Jackets (S) on pump cover and thread connection

6.3.1 TG BLOC15-50 to 86-100

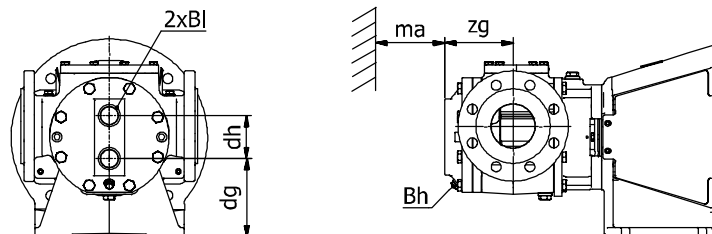

	Mat.	TG BLOC15-50	TG BLOC23-65	TG BLOC58-80	TG BLOC86-100
Bl	Cast iron (G)	G 3/4	G 3/4	G 1	G 1
	Stainless steel (R)	G 1/2	G 1/2	G 3/4	G 3/4
Bh	Cast iron (G)	-	-	G 1/4	G 1/4
	Stainless steel (R)	G 1/4	G 1/4	G 1/4	G 1/4
dh	Cast iron (G)	50	50	78	90
	Stainless steel (R)		56		
ma	Cast iron (G) / Stainless steel (R)	75	80	105	125
	Cast iron (G)	85	96	123	140
zg	Stainless steel (R)	96	110		

	TG BLOC15-50	TG BLOC23-65			TG BLOC58-80				TG BLOC86-100						
MOTOR IEC-CEI	100L/112M-B14-F165	132-B5-F265	160-B5-F300	100L/112M-B14-F165	132-B5-F265	160-B5-F300	180M-B5-F300	160-B5-F300	180L-B5-F300	200L-B5-F350	225-B5-F400	160-B5-F300	180L-B5-F300	200L-B5-F350	225-B5-F400
dg	87	125	155	87	125	155	155	141	141	161	186	135	135	155	180

6.4 Safety relief valves

6.4.1 Single safety relief valve

	TG BLOC15-50			TG BLOC23-65		
MOTOR IEC-CEI	100L/112M-B14-F165	132-B5-F265	160-B5-F300	100L/112M-B14-F165	132-B5-F265	160-B5-F300
180M-B5-F300						
dv	290	328	358	300	338	368
mc	50			50		
tg	196			196		

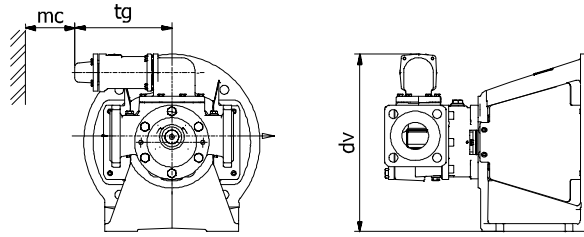

	TG BLOC58-80				TG BLOC86-100			
MOTOR IEC-CEI	160-B5-F300	180L-B5-F300	200L-B5-F350	225-B5-F400	160-B5-F300	180L-B5-F300	200L-B5-F350	225-B5-F400
dv	571	571	591	616	597	597	617	642
mc	70				70			

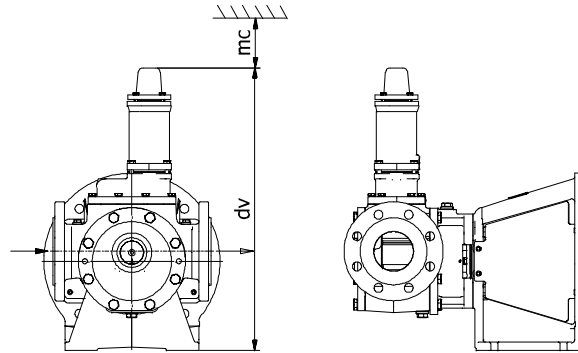

6.4.2 Double safety relief valve

	TG BLOC15-50			TG BLOC23-65		
MOTOR IEC-CEI	100L/112M-B14-F165	132-B5-F265	160-B5-F300	100L/112M-B14-F165	132-B5-F265	160-B5-F300
180M-B5-F300						
dw	391	429	459	401	439	469
mc	50			50		
tw	186.5			186.5		
tz	392			392		

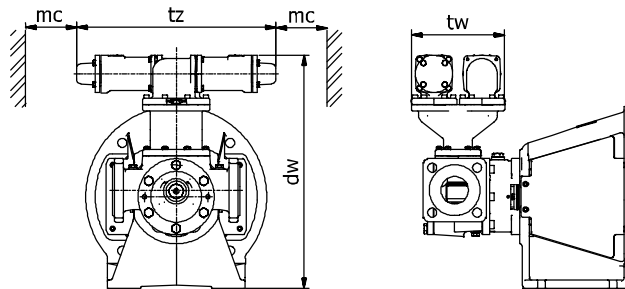

	TG BLOC58-80				TG BLOC86-100			
MOTOR IEC-CEI	160-B5-F300	180L-B5-F300	200L-B5-F350	225-B5-F400	160-B5-F300	180L-B5-F300	200L-B5-F350	225-B5-F400
dw	682	682	702	727	718	718	738	763
mc	70				70			
tv	178				219			
tw	241.5				303.5			

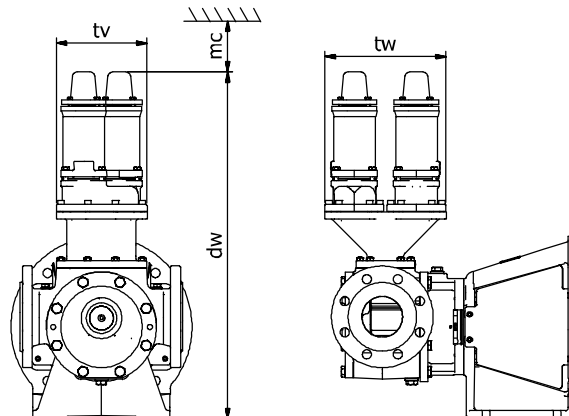

6.4.3 Heated safety relief valve

MOTOR IEC-CEI	TG BLOC15-50			TG BLOC23-65			
	100L/112M-B14-F165	132-B5-F265	160-B5-F300	100L/112M-B14-F165	132-B5-F265	160-B5-F300	180M-B5-F300
Bo	G 1/2			G 1/2			
di	107			107			
dj	125			125			
du	253	291	321	263	301	331	331
dm	63.5			61			
dn	114			114			
do	6.5			4			
dv	294	332	362	304	341	372	372
mc	50			50			
tg	196			196			

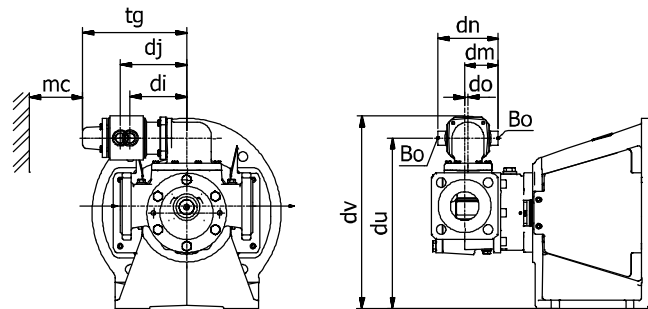

MOTOR IEC-CEI	TG BLOC58-80				TG BLOC86-100			
	160-B5-F300	180L-B5-F300	200L-B5-F350	225-B5-F400	160-B5-F300	180L-B5-F300	200L-B5-F350	225-B5-F400
Bo	G 1/2				G 1/2			
di	438	438	458	483	464	464	484	509
dj	478	478	498	523	504	504	524	549
dm	98.5				103.5			
dn	127				127			
do	6				8			
dv	571	571	591	616	597	597	617	642
mc	70				70			

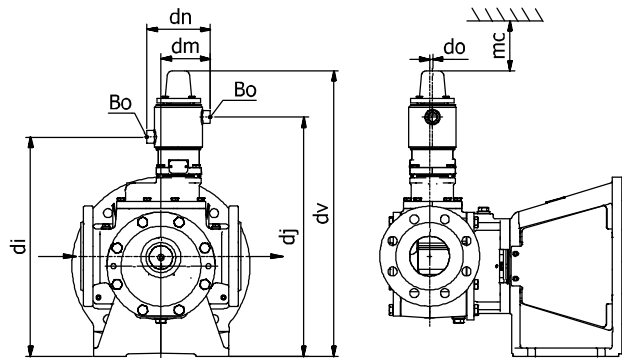

6.4.4 Heated double safety relief valve

MOTOR IEC-CEI	TG BLOC15-50			TG BLOC23-65			
	100L/112M-B14-F165	132-B5-F265	160-B5-F300	100L/112M-B14-F165	132-B5-F265	160-B5-F300	180M-B5-F300
Bo	G 1/2			G 1/2			
di	107			107			
dj	125			125			
du	354	392	422	364	402	432	432
dm	97.5			100			
dm1	110.5			108			
dn	114			114			
do	40.5			43			
do1	53.5			51			
dw	395	433	463	405	443	473	473
mc	50			50			
tw	186.5			186.5			
tg	196			196			
tz	392			392			

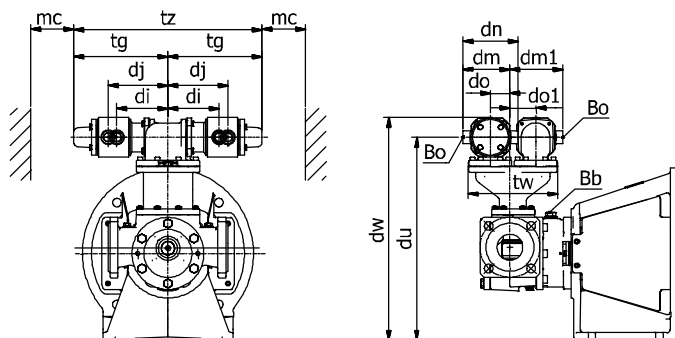

MOTOR IEC-CEI	TG BLOC58-80				TG BLOC86-100			
	160-B5-F300	180L-B5-F300	200L-B5-F350	225-B5-F400	160-B5-F300	180L-B5-F300	200L-B5-F350	225-B5-F400
Bo	G 1/2				G 1/2			
di	549.5	549.5	569.5	594.5	585.5	585.5	605.5	630.5
dj	589.5	589.5	609.5	634.5	625.5	625.5	645.5	670.5
dm	98.5				103.5			
dn	127				127			
do	55				69.5			
do1	67				85.5			
dw	682	682	702	727	718	718	738	763
mc	70				70			
tw	241.5				303.5			
tv	178				219			

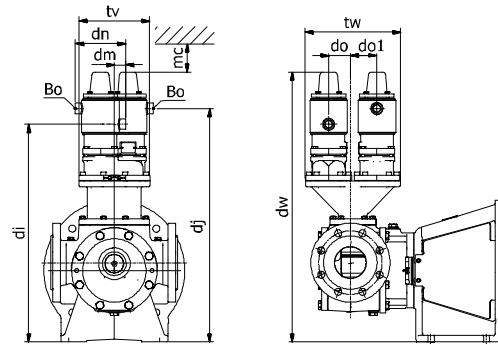

6.5 Weights – Mass

	Mat.	Lantern piece	Mass	Weight	TG BLOC15-50	TG BLOC23-65	TG BLOC58-80	TG BLOC86-100
Pump (without jackets)	Cast iron (G)	F165	kg	daN	33	38	-	-
		F265	kg	daN	37	43	-	-
		F300	kg	daN	48	53	79	95
		F350	kg	daN	-	-	83	98
	Stainless steel (R)	F400	kg	daN	-	-	94	110
		F165	kg	daN	37	42	-	-
		F265	kg	daN	41	47	-	-
		F300	kg	daN	52	57	83	100
Front-Pull out (pump cover+idler)	F350	kg	daN	-	-	87	103	
	F400	kg	daN	-	-	98	115	
	Cast iron (G)		kg	daN	2.5	3.5	9	12
	Stainless steel (R)		kg	daN	3	4	10	13
Back-Pull Out (shaft+intern. casing+lantern piece)	Cast iron (G)	F165	kg	daN	20	22	-	-
		F265	kg	daN	24	27	-	-
		F300	kg	daN	35	37	48	54
		F350	kg	daN	-	-	52	57
	Stainless steel (R)	F400	kg	daN	-	-	63	69
		F165	kg	daN	22	24	-	-
		F265	kg	daN	26	29	-	-
		F300	kg	daN	37	39	51	57
Jackets (supplement)	F350	kg	daN	-	-	55	60	
	F400	kg	daN	-	-	66	72	
	Cast iron (G)		kg	daN	2	2	5	6
	Stainless steel (R)		kg	daN	2.5	3	5	6
Relief valve (supplement)	Cast iron (G)		kg	daN	5	5	7	10
	Stainless steel (R)		kg	daN	5	5	8	11
Double relief valve (supplement)	Cast iron (G)		kg	daN	13	13	24	36
	Stainless steel (R)		kg	daN	15	15	27	39

**Declaration of Compliance
for food contact materials**

Manufacturer

SPX Flow Europe Limited - Belgium
Evenbroekveld 2-6
9420 Erpe-Mere
Belgium

We hereby certify the compliance of the materials coming into contact with food during the intended use with the general requirements as of the date of this Declaration of

Regulation (EC) No 1935/2004 of 27 October 2004 on materials and articles intended to come into contact with food and repealing Directives 80/590/EEC and 89/109/EEC.

This Declaration applies to the following product(s):

Product: **TopGear internal gear pump**

Configurations:	TG GP xx-xx FD G# OS UG6 UG6 AW	TG BLOC xx-xx FD G# O SG2 G1 WV
	TG GP xx-xx FD G# OS UR6 UR6 AW	TG BLOC xx-xx FD G# S SG2 G1 WV
	TG GP xx-xx FD G# SS UG6 UG6 AW	TG BLOC xx-xx FD R# O UR4 R4 WV
	TG GP xx-xx FD G# SS UR6 UR6 AW	TG BLOC xx-xx FD R# S UR4 R4 WV
	TG GP xx-xx FD G# OS SG2 SG2 AW	
	TG GP xx-xx FD G# OS UG6 SG2 AW	
	TG GP xx-xx FD G# SS SG2 SG2 AW	
	TG GP xx-xx FD G# SS UG6 SG2 AW	
	TG GM yy-yy FD G# OO SG2 BG2 PRAW	
	TG GM yy-yy FD G# OO UG6 BG2 PRAW	
	TG GM yy-yy FD G# OO UR6 BR6 PRAW	
	TG GM yy-yy FD G# OO SG2 SG2 GS WV	
	TG GM yy-yy FD G# OO UR6 UR8 GS WV	
	TG GM yy-yy FD G# OO UG6 SG2 GS WV	
	TG GM xx-xx FD G# OS SG2 BG2 PRAW	
	TG GM xx-xx FD G# OS UG6 BG2 PRAW	
	TG GM xx-xx FD G# OS UR6 BR6 PRAW	
	TG GM xx-xx FD G# OS SG2 SG2 GS WV	
	TG GM xx-xx FD G# OS UR6 UR8 GS WV	
	TG GM xx-xx FD G# OS UG6 SG2 GS WV	
	TG GM xx-xx FD G# SS SG2 BG2 PRAW	
	TG GM xx-xx FD G# SS UG6 BG2 PRAW	
	TG GM xx-xx FD G# SS UR6 BR6 PRAW	
	TG GM xx-xx FD G# SS SG2 SG2 GS WV	
	TG GM xx-xx FD G# SS UR6 UR8 GS WV	
	TG GM xx-xx FD G# SS UG6 SG2 GS WV	
	TG H xx-xx FD R# OO UR6 BR6 PRAW	
	TG H xx-xx FD R# OO UR6 UR8 GS WV	
	TG H xx-xx FD R# SS UR6 BR6 PRAW	
	TG H xx-xx FD R# SS UR6 UR8 GS WV	

with: xx-xx: from 6-40 to 360-150
yy-yy: from 6-40 to 23-65
#: 1, 2, 3, 4 or 5

For materials made from plastic the following additional declarations apply:

- “Certificate of compliance with EC1935/2004 food contact” for gaskets in Gylon®
by supplier Eriks+Baudoin (see page 62)
- “Certificate of compliance with EC1935/2004 food contact” for gaskets in Clipperlon
by supplier Eriks+Baudoin (see page 63)
- “Declaration acc. FDA-requirement” for mechanical seal M7N
by supplier EagleBurgmann (see page 64-65)

This Declaration shall be valid for a period of three years from the date that the pump has been shipped from our production unit. This Declaration does not modify any contractual arrangements, in particular regarding warranty and liability.

Erpe-Mere, 01 November 2021



Frank Vander Beken
Branch manager

27/09/2010

ERIKS + BAUDOIN

SPX Process Equipment BE NV
Evenbroekveld 2-4
B-9420 ERPE-MERE

Antwerpen - Anvers - Antwerp
Boombekelaan 3
B-2660 Hoboken
België - Belgique - Belgium
tel. +32-3 829 26 11
fax. +32-3 828 39 59

Conformiteitsattest EU1935/2004 voedingscontact
Attestation de conformité CE 1935/2004 contact avec des denrées alimentaires
Certificate of compliance with EC1935/2004 food contact

EN 10204 2.1

Omschrijving
Dénomination
Description

Gylon® BLUE 3504

- AQUEOUS FOOD
- FATTY FOOD
- DRY FOOD

Wij bevestigen U, dat de door ons geleverde en hierboven beschreven goederen voldoen aan de EU1935/2004 voorschriften voor gebruik in de voedingsindustrie.

Par la présente nous vous confirmons que la matériel livré en annexe, selon votre commande en référence, répond aux normes en vigueur suivant les spécifications de la CE1935/2004 (Pour produits alimentaires)

We hereby confirm that the goods supplied with the above references are suitable for contact with food in accordance with EC1935/2004 regulation

ERIKS nv

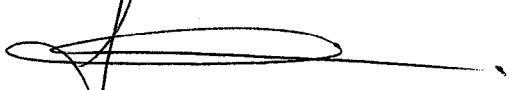
Koen Fierens
Kwaliteitsdienst
Département Qualité
Quality Department



Declaration of Compliance

Product/material **CLIPPERLON 2135 FG**
 Date of declaration 20-6-2019
 To European legislation **EC 1935/2004 EU 10/2011**
 To FDA regulation **CFR 21§177.1550**



We confirm that the above mentioned material is compliant to the above mentioned regulations and legislations. Products from this material are intended for repeated use in contact with the below listed type of foods.

This material has been evaluated according to the requirement of the of the Regulation EC 1935/2004, Annex I. Materials intended to come into contact, directly or indirectly, with food.

The safety of this material has been verified by testing against the migration requirements as described in EU 10/2011 and in accordance with EN1186.

This material has been tested following the FDA regulation on extraction.

ERIKS guarantees that all products of this material are produced according the directive for GMP (Good Manufacturing Practice) 2023/2006/EC, which is part of the guideline EC 1935/2004.

The traceability of the products derived from this material is secured and the regulations for documentation and labelling protocol have been fulfilled.

Migration test results EU 10/2011 (EN1186) - test performed on base material

Simulant	Simulant media	Type of food	Time/temperature	Ratio S/V
A	10% Ethanol	Aqueous food	4 hours at 100°C	6
B	3% Acetic acid	Acidic food with pH <4,5	4 hours at 100°C	6
D2	Olive Oil	Free fat on the surface	2 hours at 175°C	6

Extraction test results CFR 21§177.1550

Test	Requirements
Extraction in ethyl acetate 2 hours	Max. 3,1 mg/dm ²
Extraction in demi-water 2 hours	Max. 3,1 mg/dm ²
Extraction in n-heptane 2 hours	Max. 3,1 mg/dm ²
Extraction in ethanol 50% 2 hours	Max. 3,1 mg/dm ²

For more information phone +31 72 514 15 14 or E-mail info@eriks.nl

This declaration is not intended as technical documentation, the suitability of this product for a specific application should be verified with ERIKS. This declaration is valid until revocation or renewal.

ERIKS by | P.O. Box 280 | 1800 BK ALKMAAR, The Netherlands | T +31 72 5141514 | E info@eriks.nl | www.eriks.com

Bestätigung gemäß FDA-Forderung
Confirmation acc. FDA-requirement
Confirmation suivant la prescription FDA

Beleg-Nr Cert.-no.	1
Seite Page	1 von of 2

Besteller: Customer: Client:	EagleBurgmann Belgium BVBA	Best.-Nr./ Datum: Order-no./ date: No.de commande:	B104898 / 30.11.2010
Hersteller: Manufacturer: Fabricant:	EagleBurgmann Germany	Besteller-Auftr.-Nr.: Order.no.(Customer): No.de command (client):	389607
Gegenstand: Object: Désignation:	Gleitringdichtung Mechanical seal Garniture mécanique d'étanchéité	Kommission: Commisslon.-no.: No.de commande:	A70 968
Fabr.-Nr.: Fabr.-no.: No.de fabrication:	----	Zeichn.-Nr.: Drawing-no.: No. de plan:	M7N/40-00 (002391 047)
Einzelteil: component Part: pièce détachée:	Gleitringe und Gegenringe Seal faces and Stationary seats Grains tournants et Contre-grains	Stück: Quantity: Nombre:	6
		Werkstoffe: Materials: Materiaux:	Buka 22 (Q1, Q12) Buka 20 (Q2, Q22)

Bestätigung / Confirmation / Confirmation

Hiermit bestätigen wir, daß EagleBurgmann Gleitringe und Gegenringe aus den Werkstoffen Buka 20 / Buka 22 gemäß FDA-Information vom 24.05.1989 lebensmitteltauglich sind.

Herewith we certify that EagleBurgmann seal faces and stationary seats made of material Buka 20 / Buka 22 can be used in food applications in accordance with the FDA-information of may, 24.1989.

Nous confirmons par la présente que les grains tournants et les contre-grains en Buka 20 / Buka 22 de EagleBurgmann sont convenables pour l'alimentation selon la information FDA du 24.05.1989.

Bemerkungen / Remarks / Remarques

Buka 22 = SiC, Siliziumkarbid, drucklos gesintert / Silicon carbide pressureless sintered, Carbure de silicium, fritté sans pression

Buka 20 = SiC-Si, Siliziumkarbid, reaktionsgebunden / Silicon carbide reaction bonded, Carbure de silicium dép. de la réaction

EagleBurgmann Germany
GmbH & Co. KG
82502 Wolfratshausen
Telefon 08171/23-0
Telefax 08171/23-1214
www.eagleburgmann.com

Wolfratshausen, den 22.01.2011

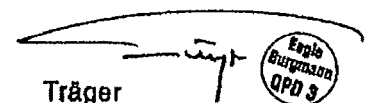
Träger 

Bestätigung gemäß FDA-Forderung
Confirmation acc. FDA-requirement
Confirmation suivant la prescription FDA

(CFR 21)

Beleg-Nr Cert.-no.	1
Seite Page	2 von of 2

Besteller: Customer: Client:	EagleBurgmann Belgium BVBA	Best.-Nr./ Datum: Order-no./ date: No.de commande:	B104898 / 30.11.2010
Hersteller: Manufacturer: Fabricant:	EagleBurgmann Germany	Besteller-Auftr.-Nr.: Order.no.(Customer): No.de command (client):	389607
Gegenstand: Object: Désignation:	Gleitringdichtung Mechanical seal Garniture mécanique d'étanchéité	Kommission: Commission.-no.: No.de commande:	A70 968
Fabr.-Nr.: Fabr.-no.: No.de fabrication:	---	Zeichn.-Nr.: Drawing-no.: No. de plan:	M7N/40-00 (002391 047)
Einzelteil: component Part: pièce détachée:	Runddichtringe O-rings Joints toriques	Stück: Quantity: Nombre:	6
		Werkstoffe: Materials: Materiaux:	V16

Bestätigung / Confirmation / Confirmation

Hiermit bestätigen wir, daß EagleBurgmann Runddichtringe aus Werkstoff V16 den Anforderungen gemäß FDA-Vorschrift "Code of Federal Regulation, Title (CFR 21), § 177.2600" entsprechen.

Herewith we certify that EagleBurgmann O-rings made of material V16 fulfill the requirements of FDA-regulation "Code of Federal Regulation, Title (CFR 21), § 177.2600".

Nous confirmons par la présente que les joints toriques EagleBurgmann en V16 sont conformes aux demandes selon la prescription FDA "Code of Federal Regulation, Title (CFR 21), § 177.2600".

Bemerkungen / Remarks / Remarques

V16 = Fluor-Kautschuk /
Fluorcarbon rubber /
Elastomère en carbone fluoré

EagleBurgmann Germany
GmbH & Co. KG
82502 Wolfratshausen
Telefon 08171/23-0
Telefax 08171/23-1214
www.eagleburgmann.com

Wolfratshausen, den 22.01.2011

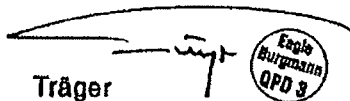
Träger 

TopGear BLOC

INTERNAL GEAR PUMPS

SPXFLOW®

SPX FLOW EUROPE LIMITED BELGIUM

Evenbroekveld 2-6

BE-9420 Erpe-Mere, Belgium

P: +32 (0)53 60 27 15

F: +32 (0)53 60 27 01

E: johnson-pump.be@spxflow.com

SPX FLOW reserves the right to incorporate our latest design and material changes without notice or obligation. Design features, materials of construction and dimensional data, as described in this bulletin, are provided for your information only and should not be relied upon unless confirmed in writing.

Please contact your local sales representative for product availability in your region. For more information visit www.spxflow.com.

ISSUED 11/2021 A.0500.751 EN

COPYRIGHT ©2020, 2021 SPX FLOW Corporation