



SPX Corporation
5885 11th Street
Rockford, IL 61109-3699 USA

Tech. Services: (800) 477-8326
Fax: (800) 765-8326
Order Entry: (800) 541-1418
Fax: (800) 288-7031

Internet Address:
<http://www.hytec.com>

Form No. 102615

Operating Instructions for:

100223

MODEL C
MANUAL PALLET VALVE
with Manifold Mount Capabilities
Max. Capacity: 5,000 PSI

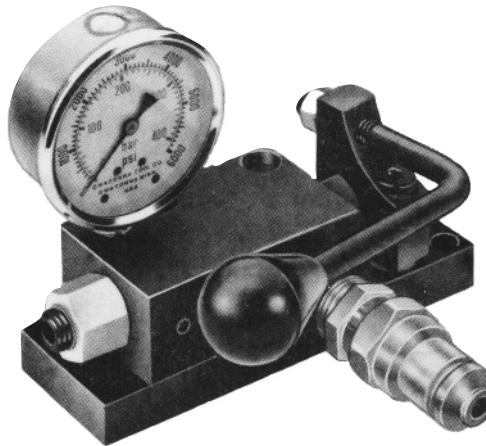

Read and carefully follow the operating instructions before installation and use of this valve. Most problems with new equipment are caused by improper operations or installation.

Note:

- Inspect the valve upon arrival. The carrier, not the manufacturer, is responsible for any damage resulting from shipment.

SAFETY PRECAUTIONS



WARNING: To help prevent personal injury;

- Before operating the pump, all hose connections must be tightened with the proper tools. Do not overtighten. Connections should only be tightened securely and leak-free. Overtightening the connections can cause premature thread failure or high pressure fittings to split at pressures lower than their rated capacities, possibly resulting in personal injury.
- Should a hydraulic hose ever rupture, burst, or need to be disconnected, immediately shift the control valve twice to release all pressure. Never attempt to grasp a leaking pressurized hose with your hands. The force of the escaping hydraulic fluid could cause serious injury.
- Do not subject the hose to potential hazard such as fire, sharp surfaces, heavy impact, or extreme heat or cold. Do not allow the hose to kink, twist, curl or bend so tightly that the oil flow within the hose is blocked or reduced. Periodically inspect the hose for wear, because any of these conditions can damage the hose and result in personal injury.
- Do not use the hose to move attached equipment. Stress can damage the hose and cause personal injury.
- Hose material and coupler seals must be compatible with the hydraulic fluid used. Hoses also must not come in contact with corrosive material such as creosote-impregnated objects and some paints. Consult the manufacturer before painting the hose(s). Never paint the couplers! Hose deterioration due to corrosive materials can result in personal injury.

Sheet No. 1 of 2

Rev. Date: 25 Aug. 1992

MOUNTING THE PALLET VALVE

There are two holes for 5/16" diameter bolts. See Figure 1 for dimensions. This valve can be mounted easily in any position, horizontal or vertical.

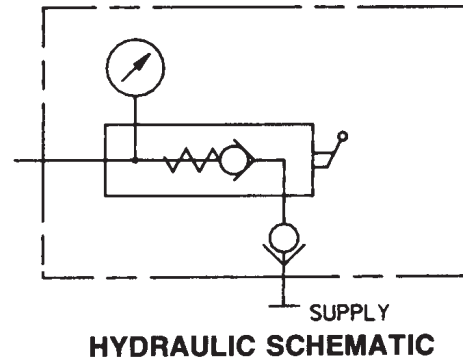
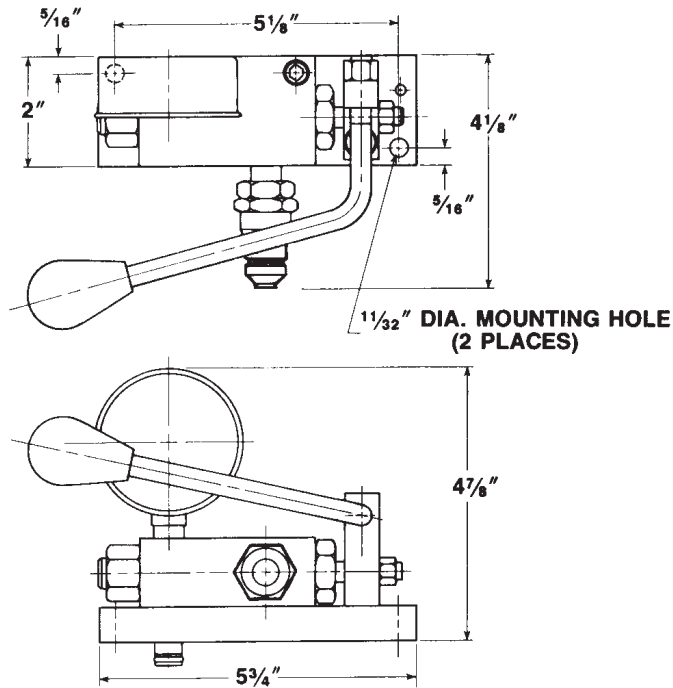

FIGURE 1

CLAMPING AND UNCLAMPING PROCEDURE

- Clamping:**
1. Connect hydraulic hose from power source to pallet valve using push-to-connect coupling.
 2. Load work pieces.
 3. Cycle the pump as described in the operating instructions for the pump.
 4. When valve gauge reads clamping pressure and pump pressure has been released, disconnect hydraulic hose.
- Unclamping:**
1. Connect hydraulic hose with push-to-connect coupling.
 2. Pull handle on valve to open or release oil in fixture.
 3. Remove work pieces.

CONVERTING A MANUAL PALLET VALVE TO MANIFOLD MOUNT

1. Remove the pressure gauge (Item #8).
2. Remove and discard the screw (Item #29) and copper washer (Item #30).
3. Install the factory assembled bushing (Item #'s 15, 16, & 31) into the base plate.
4. Replace the gauge.

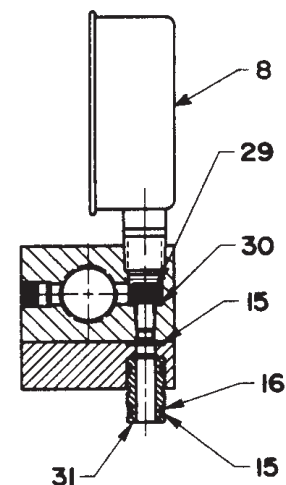

INSTALLATION INSTRUCTIONS FOR MANIFOLD MOUNT

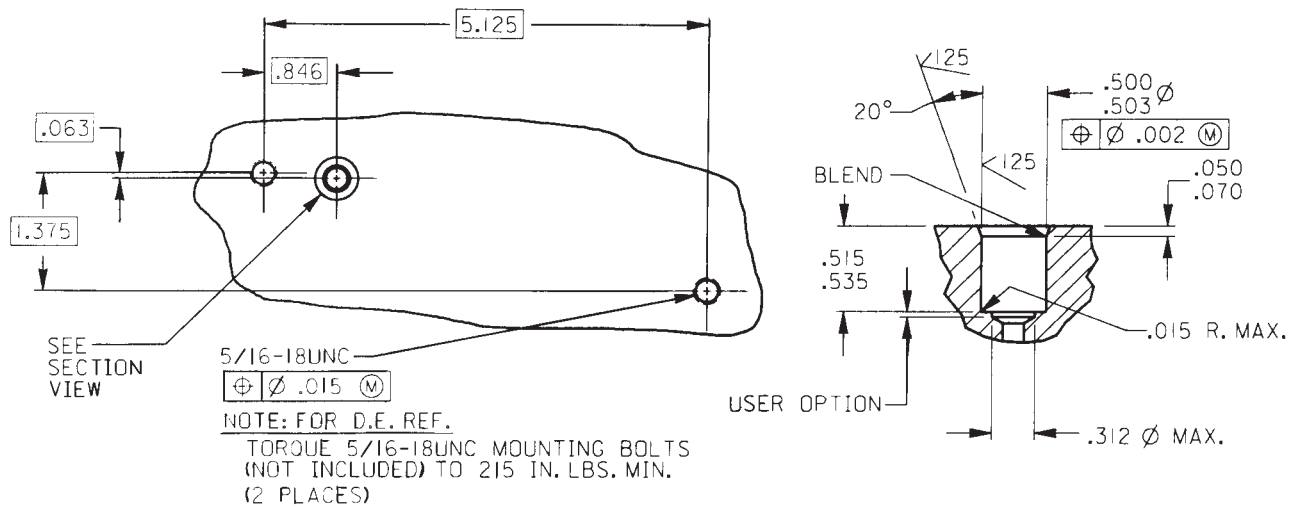

USE OF AN ACCUMULATOR--OPTIONAL

For proper operation of this system, the pallet valve should be used with an accumulator. Hytec suggests using the #100222 Accumulator which maintains pressure as the temperature changes or minor leaks occur. Refer to Form No. 102553 for more information on this accumulator. See Figure 2 for a typical application using the standard pallet valve and accumulator. See Figure 3 for a typical application using the manifold mount pallet valve and accumulator.

