

100061B



Hytec's block style cylinders are double-acting only and do not contain return springs, making them perfect for applications where rapid positive return is essential or where both pushing and pulling forces are required.

Now, more applications are possible thanks to the new threaded piston rods. Hytec threaded inserts or any custom-designed attachments may be used.

The cylinders can be mounted from top or bottom using a single cap screw and either the thru-hole on the top or the tapped hole in the bottom. A locating hole in the bottom can be used to prevent rotation when necessary.

Cylinder control can be simplified in certain

applications by supplying one side of the cylinder with a constant air pressure source to supply the return force. The other port of the cylinder can then be pressurized and released as if it were single-acting.

Features:

- Threaded, plated piston rod
- Double-acting
- Single screw mounting
- Piston threads withstand full retract forces.

Note: See page 23 for threaded inserts.

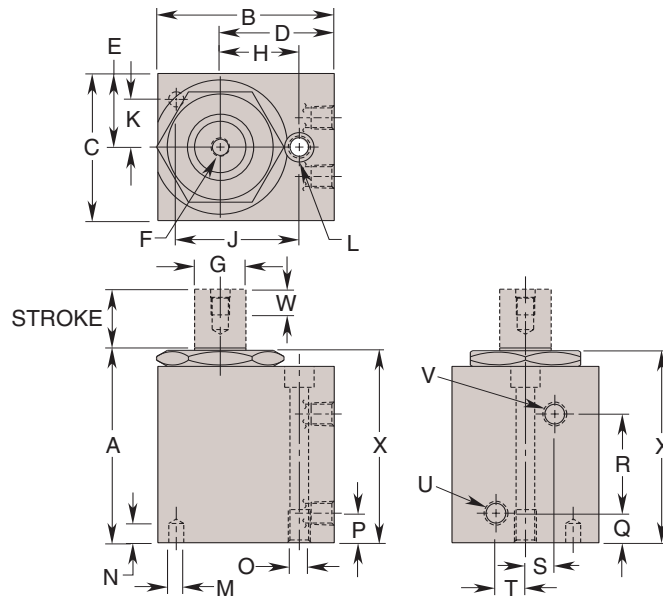
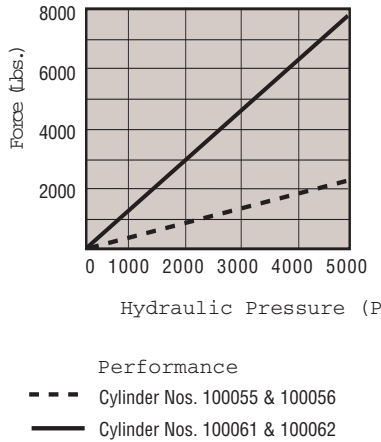

Cat. No.	Specifications					Dimensions (In Inches)															
	*Force (Lbs.)		Stroke (In.)	Eff. Area (Sq. in.)		Oil Cap. (Cu. In.)		A	B	C	D	E	F Thread Size	G Dia.	H	J	K	L Dia.	M Dia.	N	O Thread Size
	Adv.	Ret.		Adv.	Ret.	Ret.															
100055B	2210	1225	.500	.442	.245	.221	.123	2.312	2.500	1.500	1.844	.750	5/16-24 UNF	.500	1.094	1.490	.500	.257	.257	.328	5/16-18 UNC
100056B	2210	1225	1.000	.442	.245	.442	.245	2.812	2.500	1.500	1.844	.750	5/16-24 UNF	.500	1.094	1.490	.500	.257	.257	.328	5/16-18 UNC
100061B	7425	4415	.500	1.485	.883	.742	.442	2.812	3.000	2.500	1.938	1.250	5/16-24 UNF	.875	1.344	2.094	.812	.312	.257	.328	3/8-16 UNC
100062B	7425	4415	1.000	1.485	.883	1.485	.883	3.312	3.000	2.500	1.938	1.250	5/16-24 UNF	.875	1.344	2.094	.812	.312	.257	.328	3/8-16 UNC

Cat. No.	Dimensions (In Inches)								
	P Min.	Q	R	S	T	U Advance Port	V Retract Port	W Thread Depth	X (REF)
100055B	.500	.375	1.000	.344	.344	1/8-NPTF	1/8-NPTF	.438	2.23
100056B	.500	.375	1.500	.344	.344	1/8-NPTF	1/8-NPTF	.438	2.73
100061B	.625	.500	1.188	.500	.500	1/8-NPTF	1/8-NPTF	.438	2.76
100062B	.625	.500	1.688	.500	.500	1/8-NPTF	1/8-NPTF	.438	3.26

NOTE: * Based on 5,000 psi max. operating pressure