

Edge Clamps



Hytec's edge clamps perform three functions: locating the workpiece, clamping horizontally against secondary locators and clamping vertically against the primary locating surface. This combined horizontal and vertical clamping force can locate and secure many parts with no other clamps being needed.

These clamps are extremely compact relative to their clamping force and are available in either conventionally or manifold mounted versions. At only 1 inch tall, their low profile design allows them to remain below most workpieces for unrestricted machining access to a part's top surface.

The 100986 clamp is compactly designed for manifold mounting. The 100863 clamp has three pressure ports for convenient installation and easy chaining of multiple clamps. A generous .188" stroke compensates for workpiece variations. Includes removable mounting/ locating bushing.

Features:

- 15 degree clamping angle
- Hardened, serrated, plated gripper
- Single-acting
- Hardened, tool steel piston
- Three pressure ports (100863)
- Compact design
- Dual, zinc plated return springs
- Conventional and manifold mount versions

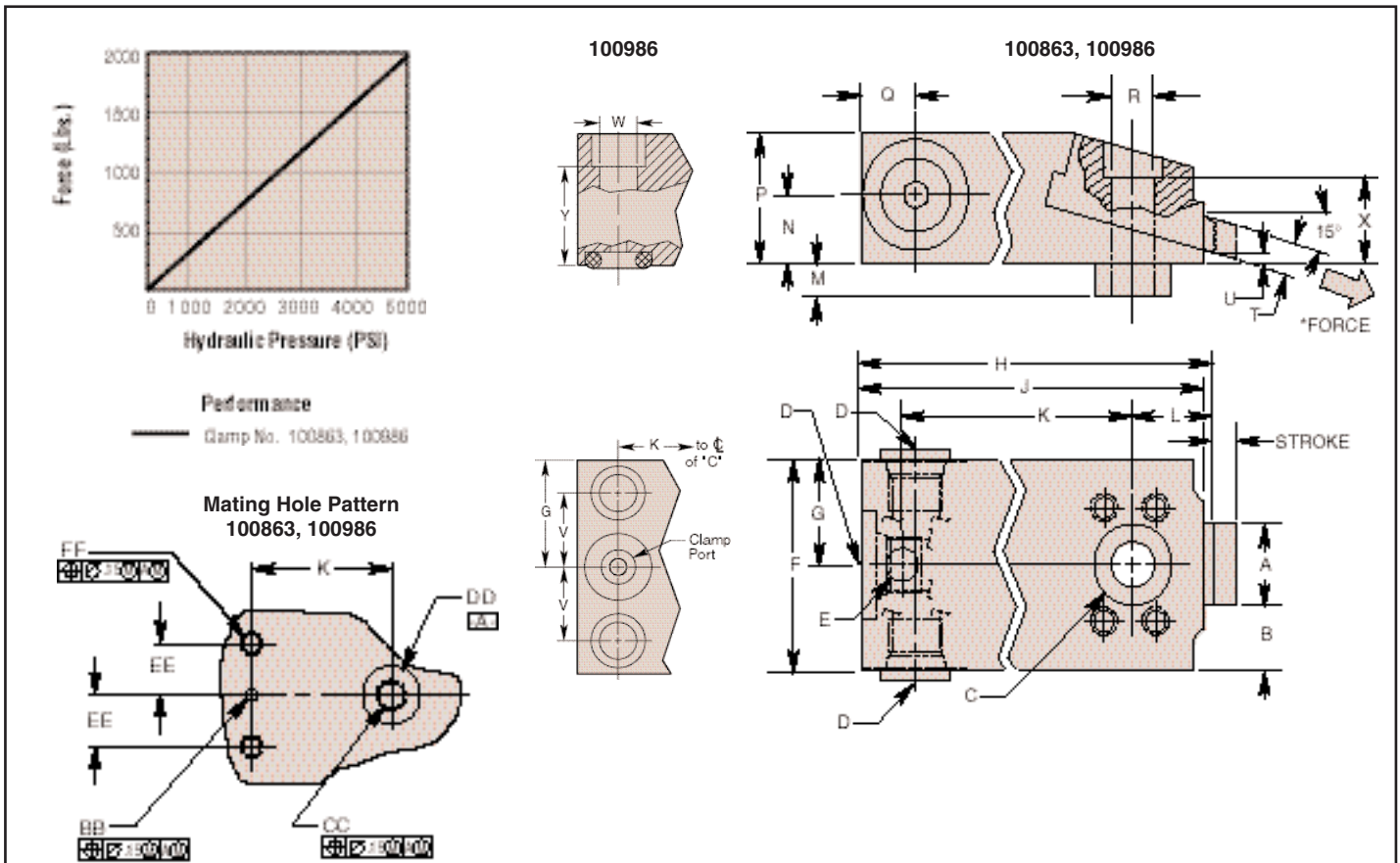

Cat. No.	Specifications				Dimensions (In Inches)												
	*Force (Lbs.)	Stroke (In.)	Eff. Area (Sq. In.)	Oil Cap. (Cu. In.)	A	B	C Dia.	D Thread Size	E		F	G	H	J	K	L	M
100863	2,000	.188	.422	.080	.625	.500	.624	1/8-20 UNF SAE-4	.250	.175	1.625	.812	2.856	2.780	1.875	.653	.240
100986																	

Cat. No.	Dimensions (In Inches)																
	N	P	Q	R Dia.	T	U	V	W	X	Y	BB Dia.		CC Thread Size	DD		EE	FF Thread Size
100863	.525	1.000	.483	.344	.250	.090	—	—	.750	—	—	‡ .250	†† 5/16-18 UNC	.626	.250	—	—
100986	—		—	.344	.250	.090	.562	.285	.750	.750	†.121 †.135	—				—	—

NOTE: * Based on 5,000 PSI max. operating pressure
 † Surface finish to be 63. Concentric tool marks only.
 †† Finish area to be .500 Ø min. centered on .135 Ø max. hole.
 ††† .312 min thread engagement required.
 †††† .250 min thread engagement required.
 ‡ Optional locating hardware not included