



100220

This electric/hydraulic pump is a two-stage, continuous pressure (demand) pump that contains all the necessary controls and circuitry for powering any single- or double-acting continuous pressure workholding system. It has a pressure switch and an external pressure regulator, both infinitely adjustable throughout the operating pressure range of 1,000 to 5,000 psi. An internal safety relief valve prevents damage from exceeding the maximum rated pressure.

It's a gear/axial piston pump designed for use in single or multiple station applications. Its high torque universal motor is low voltage

tolerant. Includes a 1/4" NPTF outlet manifold and will accept any Hytec pump-mounted valve. Shipped with two gallons of oil.

Features:

- CSA approved model available
- Drip proof universal motor
- Filtered filler/breather cap
- Liquid filled gauge
- Carrying handle
- 2.5-gallon metal reservoir
- 525 cu. in. usable oil
- Oil flow at max. pressure: 100 cu. in./min.

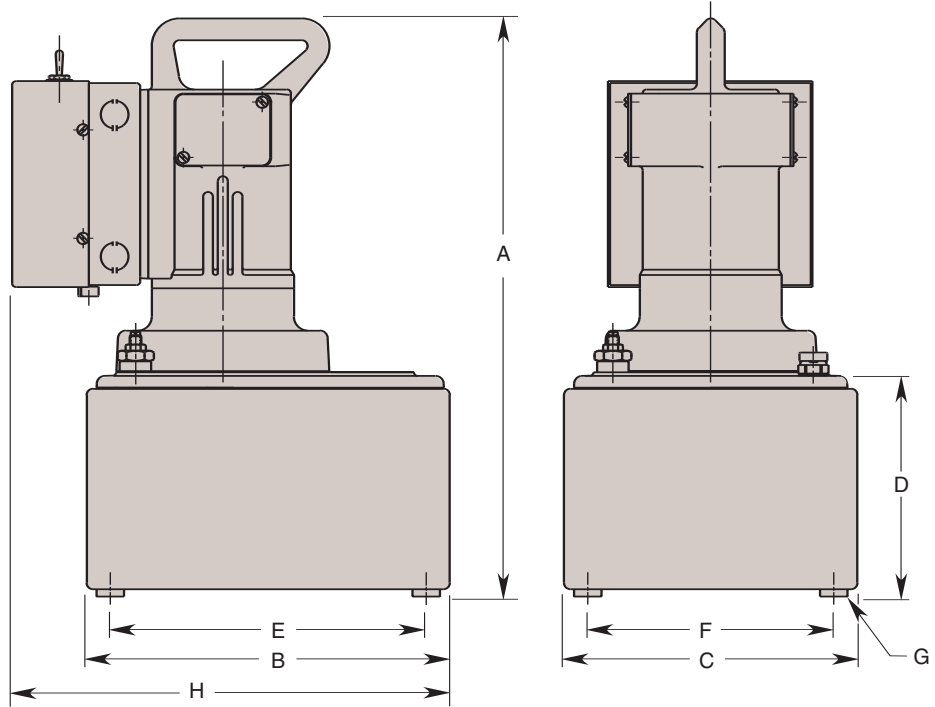
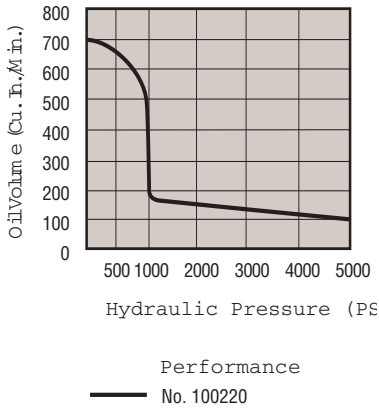

Cat. No.	Specifications			Dimensions (In Inches)							
	Electric Motor	Supply Voltage	Noise Level @ Idle/Max. Press. (dBA)	A	B	C	D	E	F	G Thread Size	H
100220	1½ hp; 12,000 rpm; 115 VAC; 25 amps max.; 50/60 Hz; single phase	115 VAC	80/85	18.250	12.500	10.500	7.000	10.000	8.000	½-20 UNF	14.000
100220-230	1½ hp; 12,000 rpm; 230 VAC; 14 amps max.; 50/60 Hz; single phase	230 VAC									

NOTE: An optional fluid level / temperature gauge is available, see page 135.