

MODEL C 50 GPM HYDRAULIC TESTER

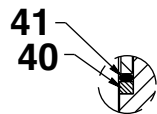

Basic Assembly

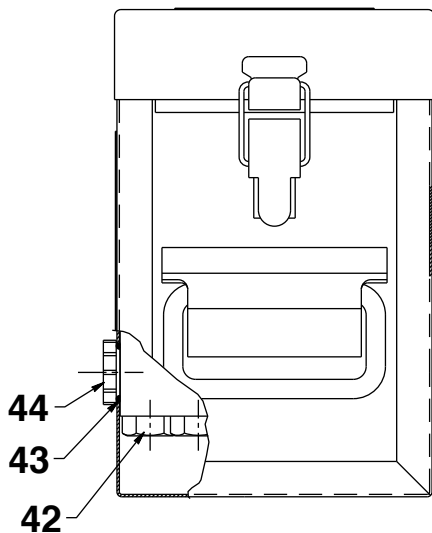
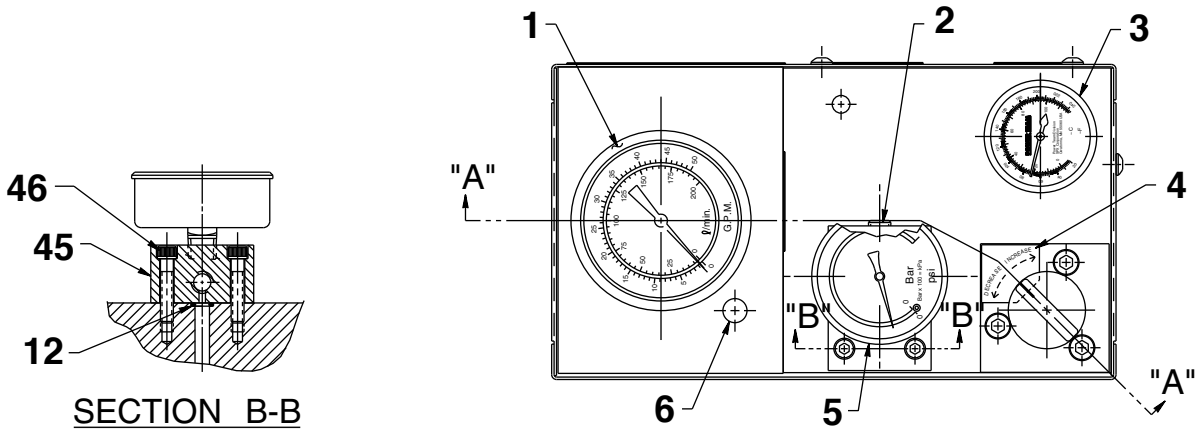

DETAIL "D"

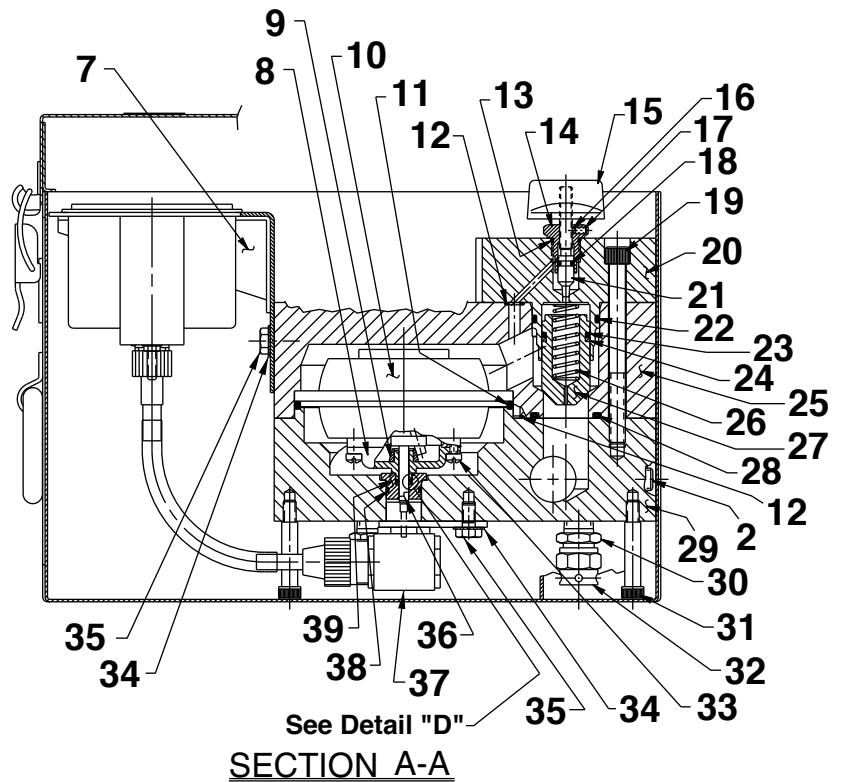

SECTION A-A

Parts List, Form No. 101718, Back sheet 1 of 2

Item No.	Part No.	No. Req'd	Description	Item No.	Part No.	No. Req'd	Description
1	213628	1	Tachometer	26	10367	1	Compression Spring (1/2 O.D. X 2" Lg.)
2	10427	2	Plug Fitting (1/8 NPTF)	27	25559	1	Poppet
3	11490	1	Temperature Gauge (2" dia.)	28	*10280	1	O-ring (1-3/8 X 1-1/8 X 1/8)
4	*12656	1	Decal (Increase/Decrease)	29	50309	1	Lower Body
5	17967	1	Gauge (1-6,000 PSI; 2-1/2" dia.)	30	21837	2	Nipple
6	205521	1	Plug Cap	31	252248	3	Screw
7	34117	1	Panel	32	*16230	2	Safety Disc Valve (5,835 PSI; Torque to 25/32 ft. lbs.)
8	23023	1	Gear Plate	33	13441	2	Screw (#10-32 X 1/4 Lg.)
9	13440	1	Roller	34	11351	3	Washer (1/4 External Tooth)
10	11489	1	Measuring Chamber	35	10005	3	Cap Screw (1/4-20 UNC X 1/2 Lg.)
11	*12599	1	O-ring (4-1/4 X 4" X 1/8)	36	351296	1	Drive Shaft
12	*10266	3	O-ring (3/8 X 1/4 X 1/16)	37	351299	1	Gear Drive (Note: Grease with Mobile Mobilegrease HP; See note below)
13	*10300	1	O-ring (5/8 X 15/32 X 5/64)	38	11284	1	O-ring (11/16 X 9/16 X 1/16)
14	26571	1	Tapped Guide	39	25564	1	Shaft Seal
15	12721	1	Instrument Knob	40	*12556	1	PTFE Seal Ring
16	24463	1	Nylon Insert	41	*12557	1	O-ring (11/32 X 7/32 X 1/16)
17	10587	1	Set Screw (#8-32 X 3/16 Lg.)	42	12720	5	Cap Screw (5/8-11 X 2-3/4 Lg.; Torque to 90/110 ft. lbs.)
18	*10265	1	O-ring (5/16 X 3/16 X 1/16)	43	*12745	2	O-ring (1-5/32 X .924 X .116)
19	11030	3	Screw (5/16-18 X 3-1/2 Lg.)	44	12672	2	Plastic Dust Plug
20	32439	1	Flow Control Body	45	46707	1	Gauge Manifold Body
21	25738	1	Regulator Valve	46	10020	2	Cap Screw (1/4-20 UNC X 1-1/4 Lg.)
22	*12598	1	O-ring (1-5/16 X 1-1/8 X 3/32)				
23	*10275	1	O-ring (15/16 X 3/4 X 3/32)				
24	*14489	1	Backup Washer (15/16 X 3/4 X .048)				
25	50308	1	Upper Body				

Part numbers marked with an asterisk (*) are included in Repair Kit No. 300097.

Note: To order the flex drive portion only of this drive gear, order no. 252245.



Refer to any operating instructions included with this product for detailed information about operation, testing, disassembly, reassembly, and preventive maintenance.

Items found in this parts list have been carefully tested and selected. **Therefore: Use only genuine Power Team replacement parts!**

Additional questions can be directed to one of our Technical Services Departments.

Note: Asterisks (*) added at last revision(s) made to this form.

HOUSING ASSEMBLY

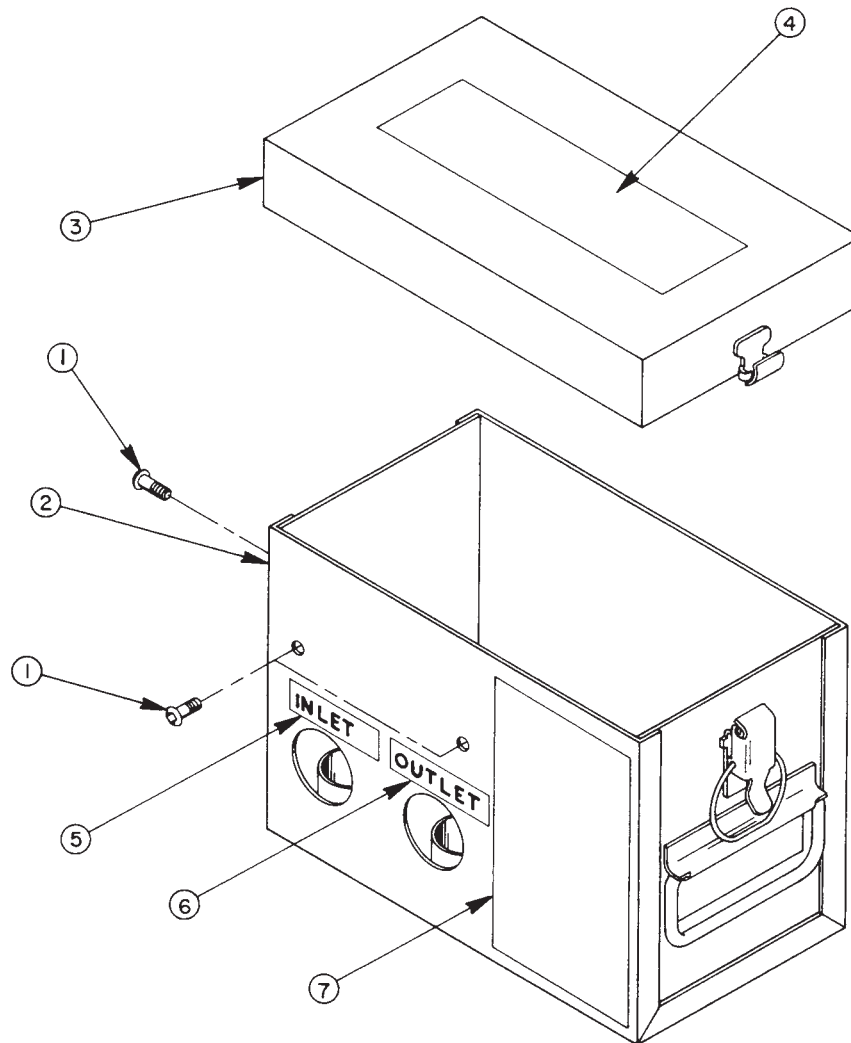

Item No.	Part No.	No. Req'd	Description
1	15911	3	Cap Screw (1/4-20 X 5/8 Lg.)
2	50340BK2	1	Case
3	40844WH2	1	Cover
4	351317	1	Trade Name Decal
5	*207804	1	Decal
6	*207805	1	Decal
7	307363	1	Instruction Decal

Part numbers marked with an asterisk (*) are included in Repair Kit No. 300097.