

# BI-DIRECTIONAL™

## Hydraulic Pullers

17½, 30-50 Ton

The power to make impossible jobs become routine.

- Can apply a hydraulic pushing or pulling force, depending on how the puller is set up.
- Each unit includes perfectly matched hydraulic components that can be detached from the Bi-Directional™ Puller for other tasks requiring dependable Power Team power; assuring maximum return on your investment.
- Optional leg kits adapt your Bi-Directional™ Puller to extra long or extra short reach.
- A wide variety of threaded adapters, bearing pulling attachments and internal pulling attachments can be used in combination with our Bi-Directional™ Pullers.

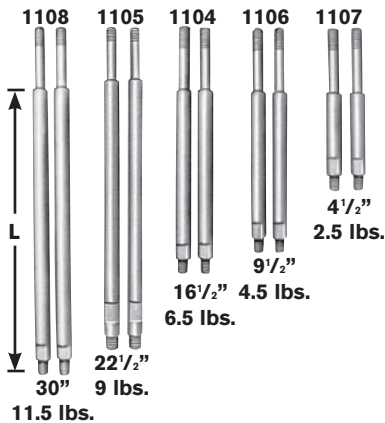

**NOTE:** L = leg length: 4½", 9½", 16½", 22½", 30"; subtract 4⅞" from leg length to determine reach when using leg end caps.

### ASSEMBLING THE TOOL TO APPLY PUSHING OR PULLING FORCE:

- Determine if you want the tool's forcing screw to push or pull.
- To exert pushing force, the forcing nut is installed beneath the cross block, as shown on left.
- To cause the forcing screw to pull, the forcing nut is placed on top of the cross block.
- The sliding plates must always be placed on the opposite side of the cross block from the forcing nut.

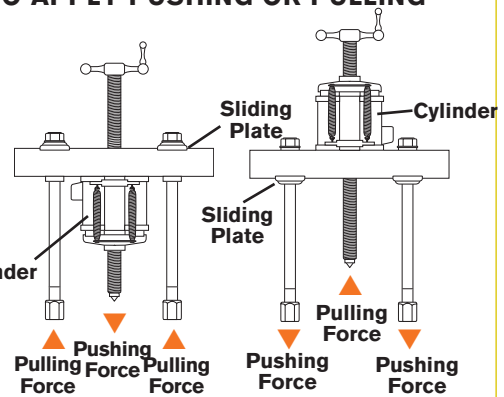

**Selection and capacity rating** – Each Bi-Directional Puller's specified tonnage "capacity" is determined using its standard

legs in tension. Using longer legs, or a setup in which the legs are in compression, will reduce the "capacity." Always select the largest "capacity" puller and the shortest legs that will fit the job.

**Power Twin® cylinder** – This unique center-hole cylinder powers each Bi-Directional™ Puller screw runs right between the twin spring cylinder. A basic head allows you to change from a tapped hole to a plain hole by merely changing the head insert.

#### 17½ ton capacity Bi-Directional™ Puller–

**No. PPH17** – Bi-Directional™ Puller with RT172 center-hole Power Twin® cylinder, cylinder half coupler, P55 pump, 9767 6-ft. hose, 9798 hose half coupler, 16½" legs, 24827 leg ends, 1"-8 x 20" large adjusting screw and adjusting crank. Wt., 59 lbs.

**No. PPH17R** – Same as above, but without P55 pump, 9767 6-ft. hose and 9798 hose half coupler. Wt., 40 lbs.

**No. 1062** – Puller only. (Cylinder, pump, hose, coupler, screw and crank not included). Wt., 20 lbs.

#### USE WITH:

Bearing pulling attachments: **Nos. 1124 and 1130.**

Pulley pulling attachment: **No. 679.**

Internal pulling attachment: **No. 1154.**

Legs: **Nos. 1104, 1105, 1106, 1107 and 1108** - Pair of legs for 17½-ton "capacity" Bi-Directional™ Puller.

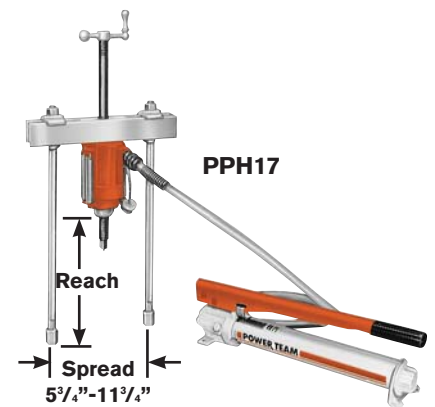

**Leg Ends** – Upper leg ends are threaded ¾"-16. Lower leg ends are threaded ⅝"-18" lg.

### 30 ton capacity Bi-Directional™ Puller

**No. PPH30** – Bi-Directional™ Puller with RT302 center-hole Power Twin® cylinder, cylinder half coupler, P55 pump, 9767 6-ft. hose, 9798 hose half coupler, 18" legs, 28390 leg ends, 1 1/4"-7 x 24" lg. adjusting screw and adjusting crank. Wt., 102 lbs.

**No. PPH30R** – Same as above, but without P55 pump, 9767 6-ft. hose and 9798 hose half coupler. Wt., 82 lbs.

**No. 1070** – Puller only. (Cylinder, pump, hose, coupler, screw and crank not included). Wt., 42 lbs.

#### USE WITH:

Bearing pulling attachments: **No. 680** (Use two 8012 adapters to connect to puller.)

Pulley pulling attachment: **No. 679**.

Internal pulling attachment: **No. 1166**.

Legs: **Nos. 1109, 1110 and 1111** - Pair of legs for 30 ton "capacity" Bi-Directional™ Puller.

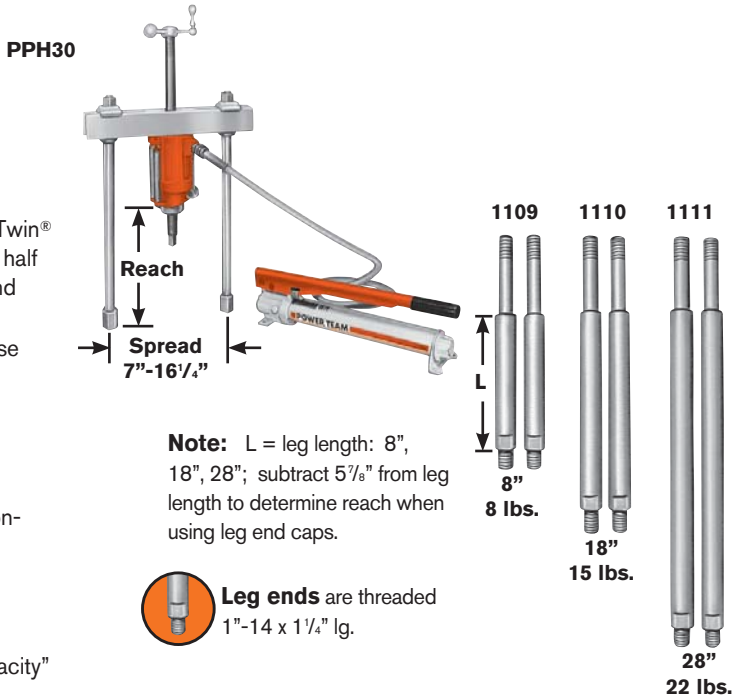

### 50 ton capacity Bi-Directional™ Puller

**No. PPH50** – Bi-Directional™ Puller with RT503 center-hole Power Twin® cylinder, cylinder half coupler, P55 pump, 9767 6-ft. hose, 9798 hose half coupler, 24" legs, 1 5/8"-5 1/2 x 30 3/8" large. adjusting screw and adjusting crank. Wt., 201 lbs.

**No. PPH50R** – Same as above, but without P55 pump, 9767 6-ft. hose and 9798 hose half coupler. Wt., 181 lbs.

**No. 1076** – Puller only. (Cylinder, pump, hose, coupler, screw and crank not included.) Wt., 106 lbs.

#### USE WITH:

Bearing pulling attachments: **Nos. 1128**.

Legs: **Nos. 1112 and 1113** - Pair of legs for 50 ton "capacity" Bi-Directional™ Puller.

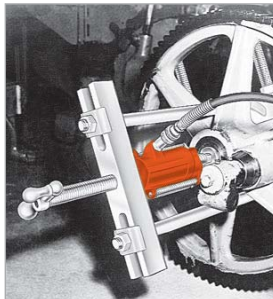
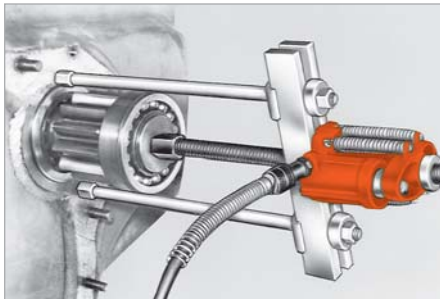
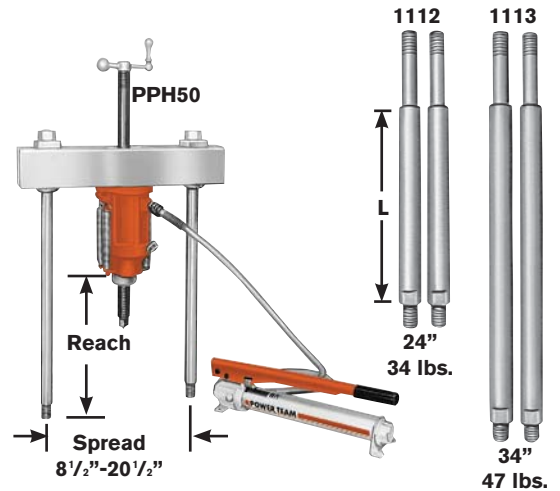

**Leg ends** are threaded 1 1/4"-12 x 1 3/4" lg.

