

Dimensions in MILLIMETRES

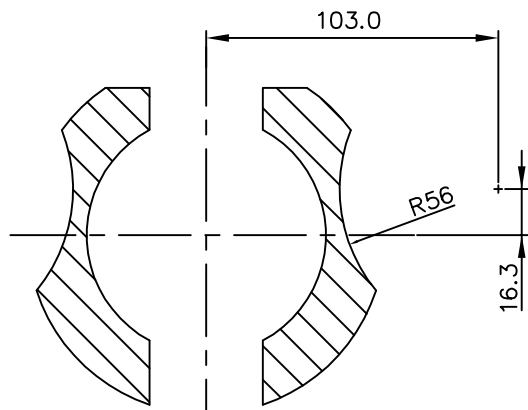
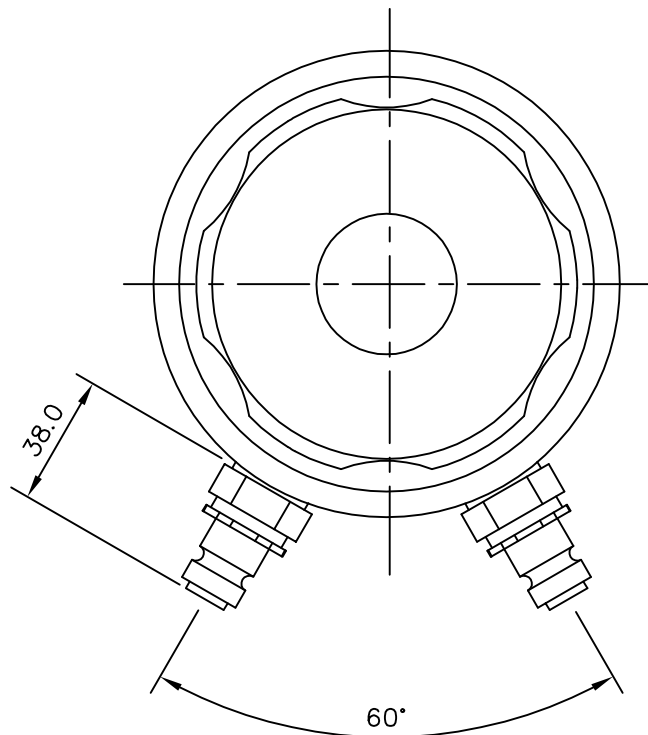
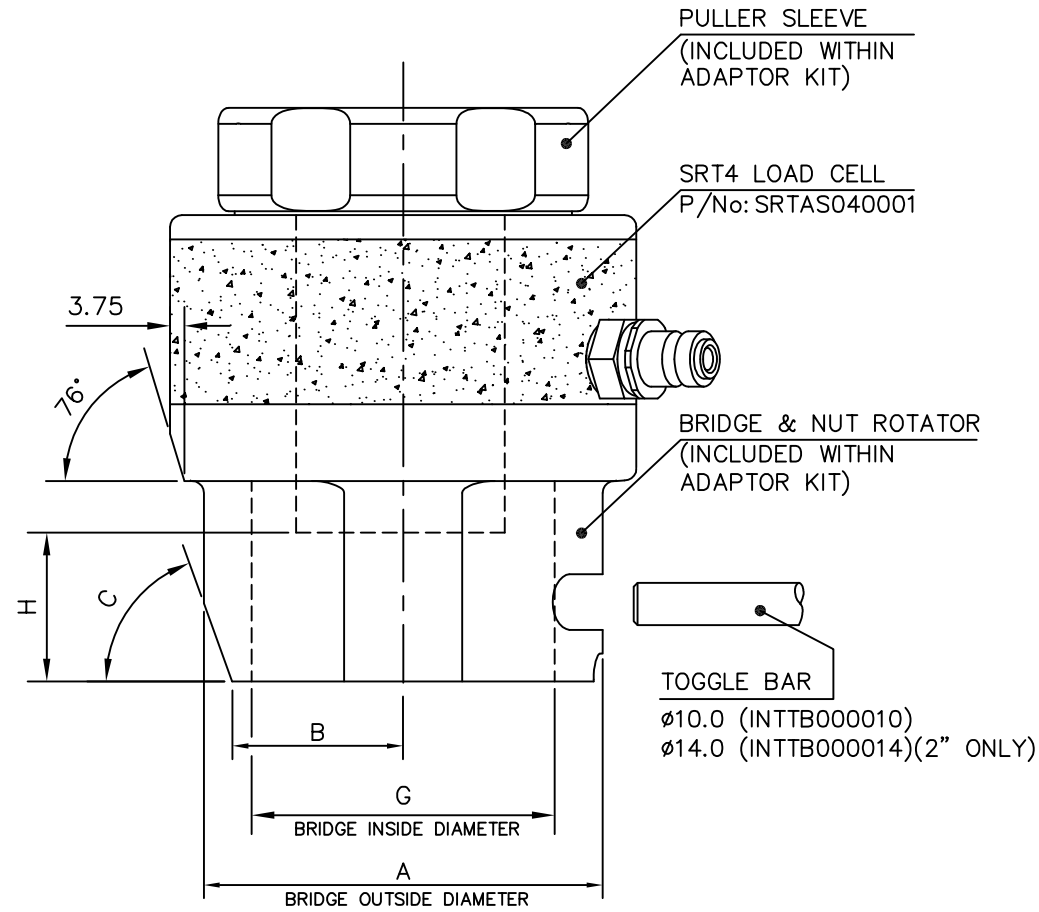
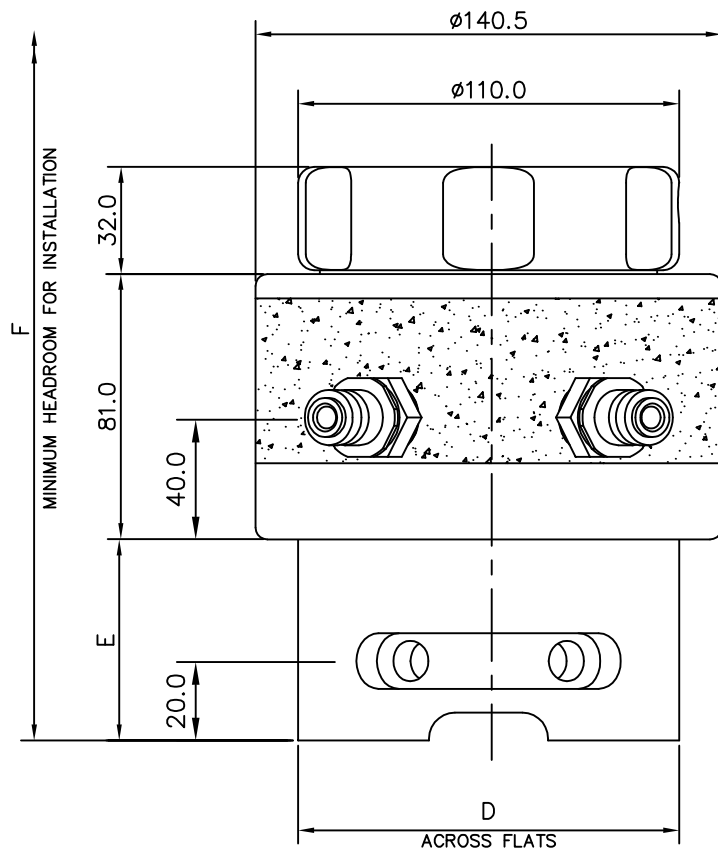

DETAIL A
SRT4 1-3/4"/M45 BRIDGE
FOOTPRINT DETAIL 2010 ONWARD
(PREVIOUS DESIGN $\phi A=118.0$, NO FLATS)

BOLT/NUT INFORMATION

DO NOT SCALE

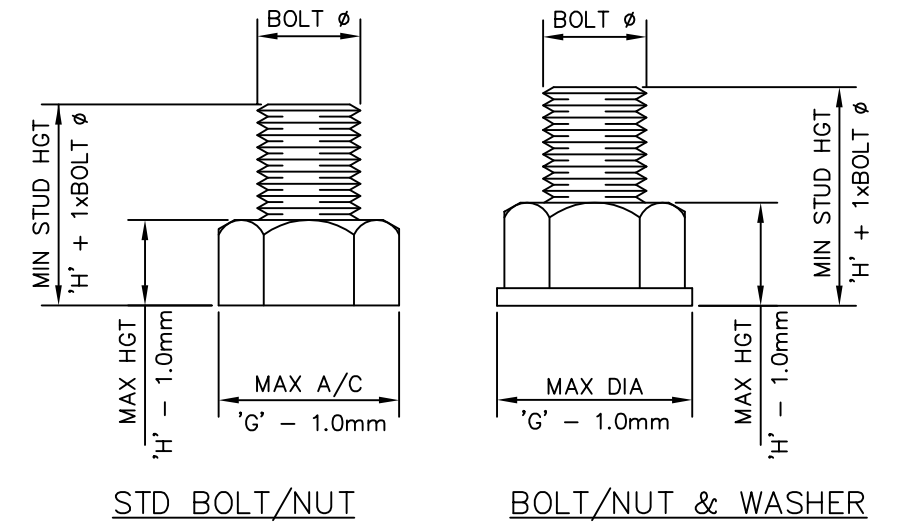

SRT4 TENSIONER SPECIFICATIONS

- MAX WORKING PRESSURE : 1500 Bar (21,750 psi)
- MAX STROKE : 10 mm (0.394")
- HYDRAULIC AREA : 6668 mm² (10.34 in²)
- LOAD AT MWP : 1000 kN (224820 lbf)

TENSIONER FEATURES

- AUTOMATIC SPRING RETURN PISTON
- OVERSTROKE ELIMINATOR VALVE
- PISTON STROKE INDICATOR
- QUICK CONNECT ADAPTOR KIT

BOLT DIA	NUT A/F	ADAPTOR KIT PART NUMBER	A mm	B mm	C mm	D mm	E mm	F mm	G mm	H mm
1-1/2" 8UN	2-3/8"	SRTAS040004	112.0	42.0	64*	-	50.5	211.0	73.0	42.5
1-5/8" 8UN	2-9/16"	SRTAS040006	114.0	45.0	67*	-	53.5	217.0	79.0	45.5
1-3/4" 8UN	2-3/4"	SRTAS040008	126.0	52.0	69*	DETAIL A	57.0	225.0	84.5	49.0
1-7/8" 8UN	2-15/16"	SRTAS040010	123.0	51.0	68*	114.0	60.0	230.0	89.5	52.0
2" 8UN	3-1/8"	SRTAS040012	128.0	52.0	61*	120.0	63.0	236.0	95.5	55.0

M39 x 4.0	60mm	SRTAS040014	112.0	42.0	64*	-	50.5	212.0	73.0	35.5
M42 x 4.5	65mm	SRTAS040015	114.0	45.0	67*	-	53.5	218.0	79.0	38.0
M45 x 4.5	70mm	SRTAS040016	126.0	52.0	69*	DETAIL A	57.0	225.0	84.5	40.0
M48 x 5.0	75mm	SRTAS040017	123.0	51.0	68*	114.0	60.0	231.0	89.5	42.0

NOTE: METRIC ADAPTOR KITS DESIGNED TO SUIT NUTS TO BS3692 (i.e. NUT HEIGHT APPROX 0.8 x BOLT DIA)

© SPX Bolting Systems

The information on this sheet is on licence to SPX Bolting Systems. It is confidential and must only be used for the purpose for which it is supplied. It must not be copied or communicated to any third party without permission in writing from SPX Bolting Systems.

General Tol.	Quantity	Material	Heat Treatment	Finish Processes			
±0.25 USO	-	-	-	-			
Surface Finish							
3.2 µm USO							
Geometric Tol.	Drawn by		Checked by	File Name	Date	Scale	
◎ 0.10	I.O'BRIEN		T.DODDS	-	07/09/2011	NTS	
// 0.20							
⊕ 0.25							
				Title		SRT4 HYDRAULIC TENSIONER GA	
				Drawing Number		SRTGA040001	
				Edition		1	
				Sheet		1/1	

Rev	Revision Description	Date	Signature	Checked
1	BOLT DATA ADDED	25/9/13	D.CAMPBELL	A.DONALDSON