

Dimensions in MILLIMETRES

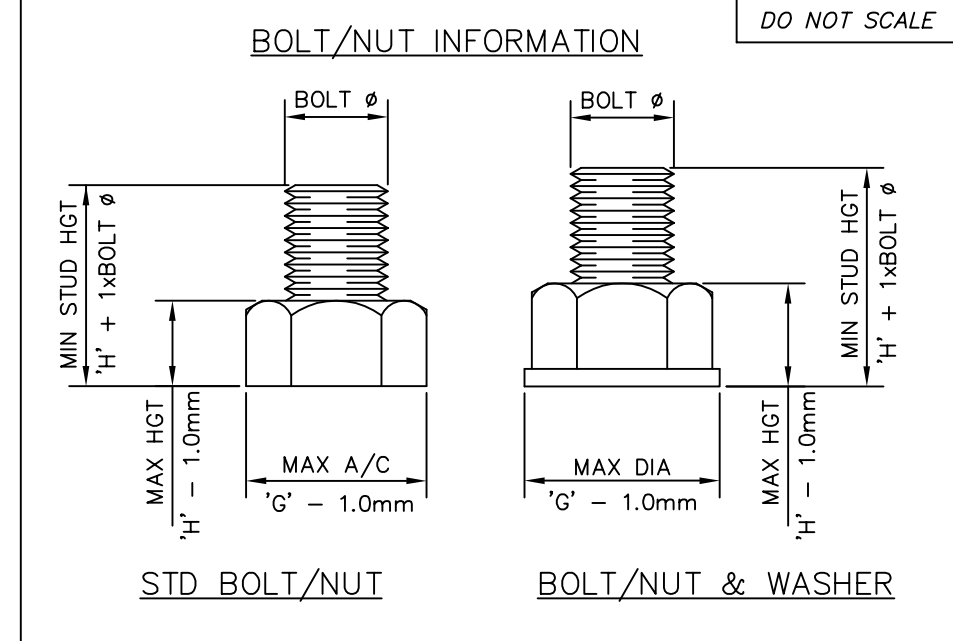
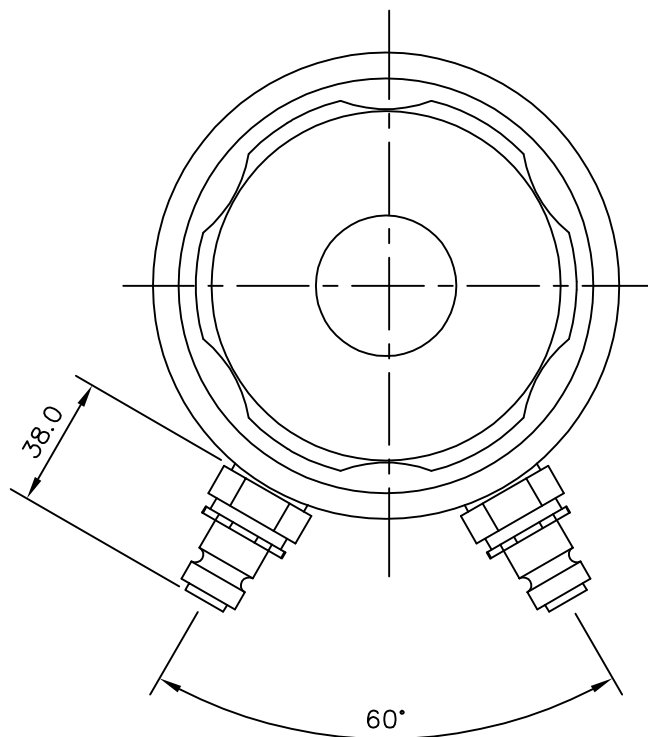
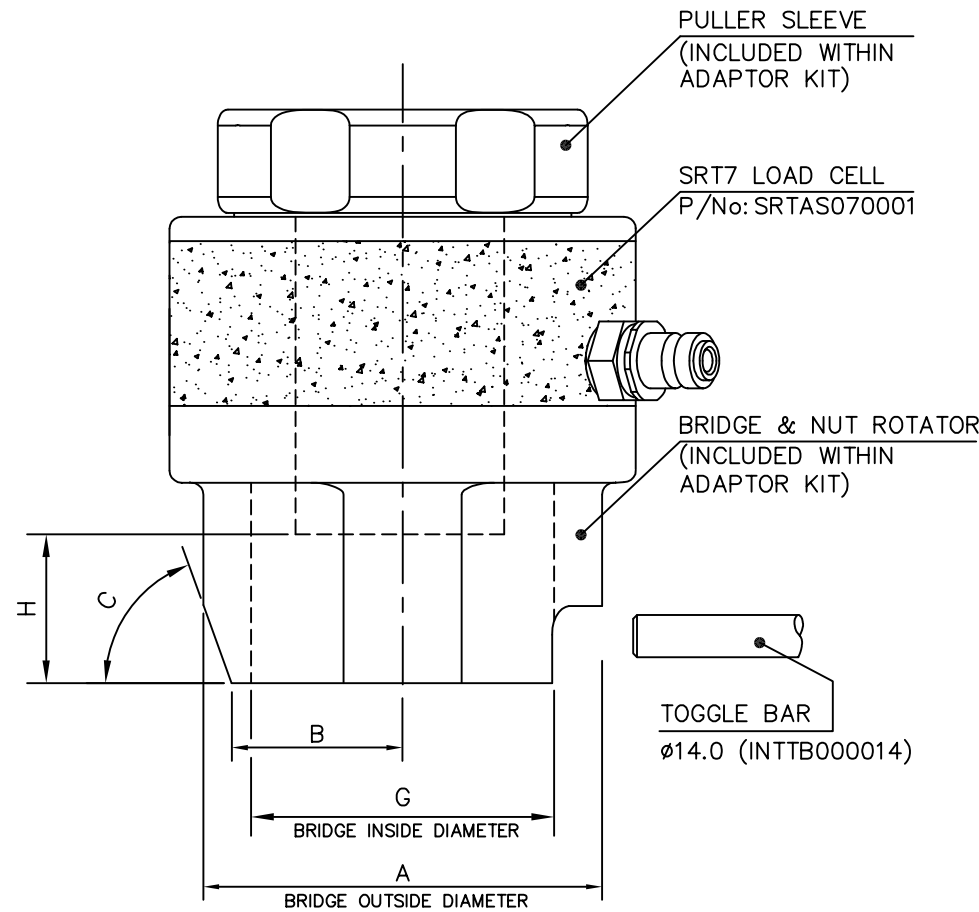
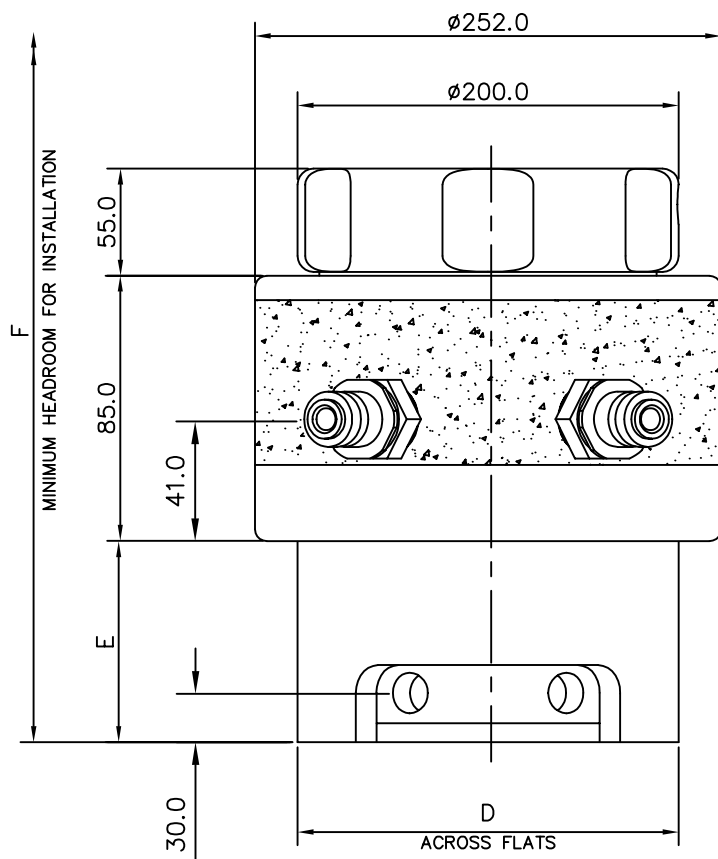

SRT7 TENSIONER SPECIFICATIONS

- MAX WORKING PRESSURE : 1500 Bar (21,750 psi)
- MAX STROKE : 10 mm (0.394")
- HYDRAULIC AREA : 21339 mm² (33.08 in²)
- LOAD AT MWP : 3200 kN (719424 lbf)

TENSIONER FEATURES

- AUTOMATIC SPRING RETURN PISTON
- OVERSTROKE ELIMINATOR VALVE
- PISTON STROKE INDICATOR
- QUICK CONNECT ADAPTOR KIT

BOLT DIA	NUT A/F	ADAPTOR KIT PART NUMBER	A mm	B mm	C mm	D mm	E mm	F mm	G mm	H mm
3-1/2" 8UN	5-3/8"	SRTAS070004	230.0	88.0	60°	200.0	101.0	339.0	163.0	93.0
3-3/4" 8UN	5-3/4"	SRTAS070006	235.0	94.0	60°	200.0	107.0	352.0	174.0	99.0
4" 8UN	6-1/8"	SRTAS070008	242.0	114.0	60°	210.0	114.0	366.0	185.0	106.0

M90 x 6.0	130mm	SRTAS070010	230.0	88.0	60°	200.0	101.0	341.0	163.0	76.0
M95 x 6.0	135mm	SRTAS070012	230.0	88.0	60°	200.0	101.0	346.0	163.0	80.0
M100 x 6.0	145mm	SRTAS070014	235.0	94.0	60°	200.0	107.0	357.0	174.0	84.0

NOTE: METRIC ADAPTOR KITS DESIGNED TO SUIT NUTS TO BS3692 (i.e. NUT HEIGHT APPROX 0.8 x BOLT DIA)

© SPX Bolting Systems

The information on this sheet is on licence to SPX Bolting Systems. It is confidential and must only be used for the purpose for which it is supplied. It must not be copied or communicated to any third party without permission in writing from SPX Bolting Systems.

General Tol. ±0.25 US0	Quantity -	Material -	Heat Treatment -	Finish Processes -
Surface Finish 3.2 µm US0	Drawn by I.O'BRIEN		Checked by D.CAMPBELL	Date 04/06/2013
Geometric Tol. ◎ 0.10 // 0.20 ⊕ 0.25	File Name -		Scale NTS	
SPX			Title SRT7 HYDRAULIC TENSIONER GA	
Drawing Number SRTGA070001			Edition 1	Sheet 1/1

Rev	Revision Description	Date	Signature	Checked
1	BOLT DATA ADDED	25/9/13	D.CAMPBELL	I.O'BRIEN