

**PULL CYLINDER**  
**FOR WORKHOLDING FIXTURES**  
**Max. Capacity: 5,000 PSI**

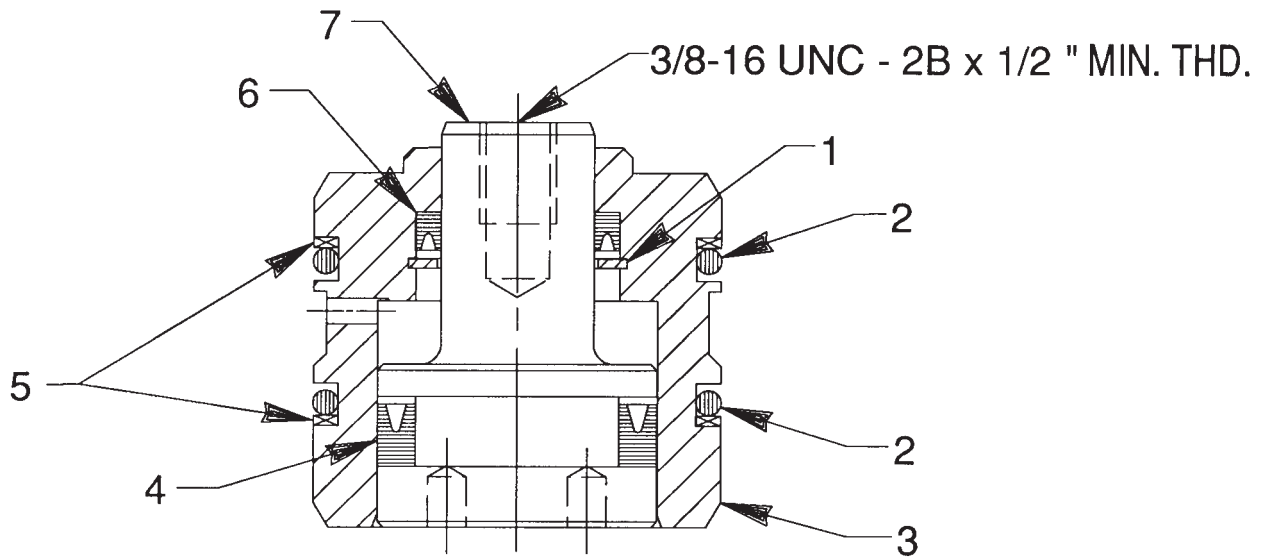

Item No.	Part No.	No. Req'd	Description
1	12994	1	Retaining Ring
2	*10294	2	O-ring (2" x 1-3/4 x 1/8, -224)
3	420597	1	Cylinder Body
4	*251552	1	U-cup (disogren)
5	*19145	2	Backup Washer (2" x 1-3/4 x .048, -224)
6	*16585	1	U-cup
7	420596	1	Piston Rod (For 100866)
	420795	1	Piston Rod (For 100880)

Part numbers marked with an asterisk (\*) are contained in Repair Kit No. 300637.

## SAFETY PRECAUTIONS

### WARNING

The buyer of this Hytec pull cylinder must be responsible for the safety of its users. This cylinder is only a component of a larger system that is purchased or designed by the buyer. The cylinder is rated at 5,000 PSI maximum. Installation of this cylinder will require user supplied mounting cavities and oil supply passages which can safely withstand the highest hydraulic working pressure expected in the application. These cavities must be designed with an appropriate safety factor to resist the fatigue of repeated hydraulic pressurization and release. In addition, forces generated by the cylinder against the cavity must be considered.

Only the system designer can know of all application specific details affecting operator safety. Systems using this cylinder must be designed only by persons qualified to ensure safety.

The cylinders are designed to be used in applications that "capture" the cylinder to prevent cylinder body movement and to stop the piston when fully retracted. Do not pressurize the installation cavity unless the cylinder body and piston rod are securely fastened and cannot be ejected from the application.

## INSTALLATION INSTRUCTIONS

**Note:** To maintain minimum size, there are no rod wiper seals in these cylinders. In most cases, the cylinders are mounted deep within the fixture and are not directly exposed to the machining environment. The designer should take steps to prevent contaminant buildup around the piston.

For longest life of the fastener connecting the piston rod in your application, the cylinder must pull straight. Do not off-center load the cylinder by pulling on a linkage at an angle or by having clamping elements that cause deflection of the fastener as they contact the workpiece.

For longest seal life, the bore containing these cylinders must be smooth. We recommend a 65 micro-inch finish maximum. The specified chamfer and the intersecting oil passage must also be properly deburred and blended to prevent seal damage as the cylinder is inserted into the bore.

The following installation instructions and illustrations describe the area where the intersecting oil passage hole(s) must be located. Any chamfering, deburring or blending of this hole must be completely within this range.

## TYPICAL APPLICATION

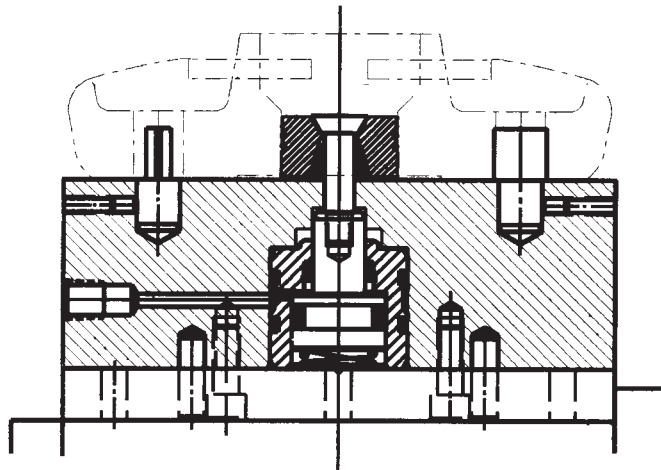

### TOP MOUNTING SPECIFICATIONS

**Mounting bores and oil supply passage dimensions for installation from piston rod end:**

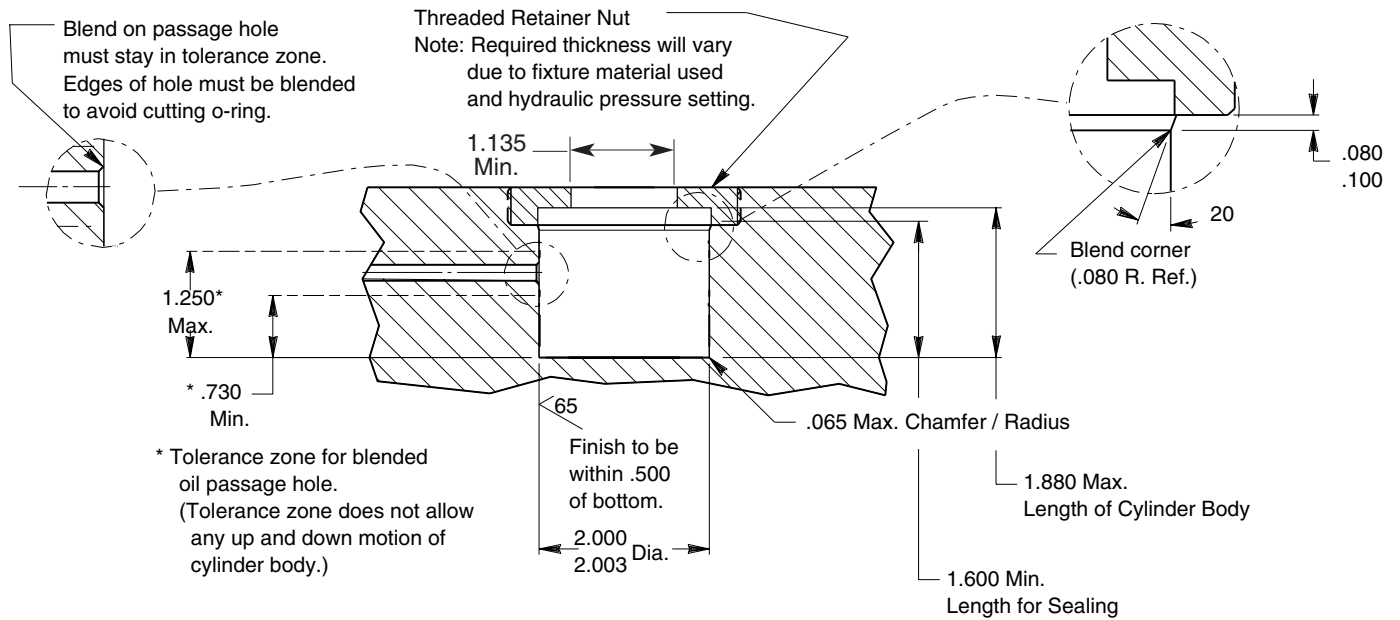

**Cylinder in mounting cavity:**

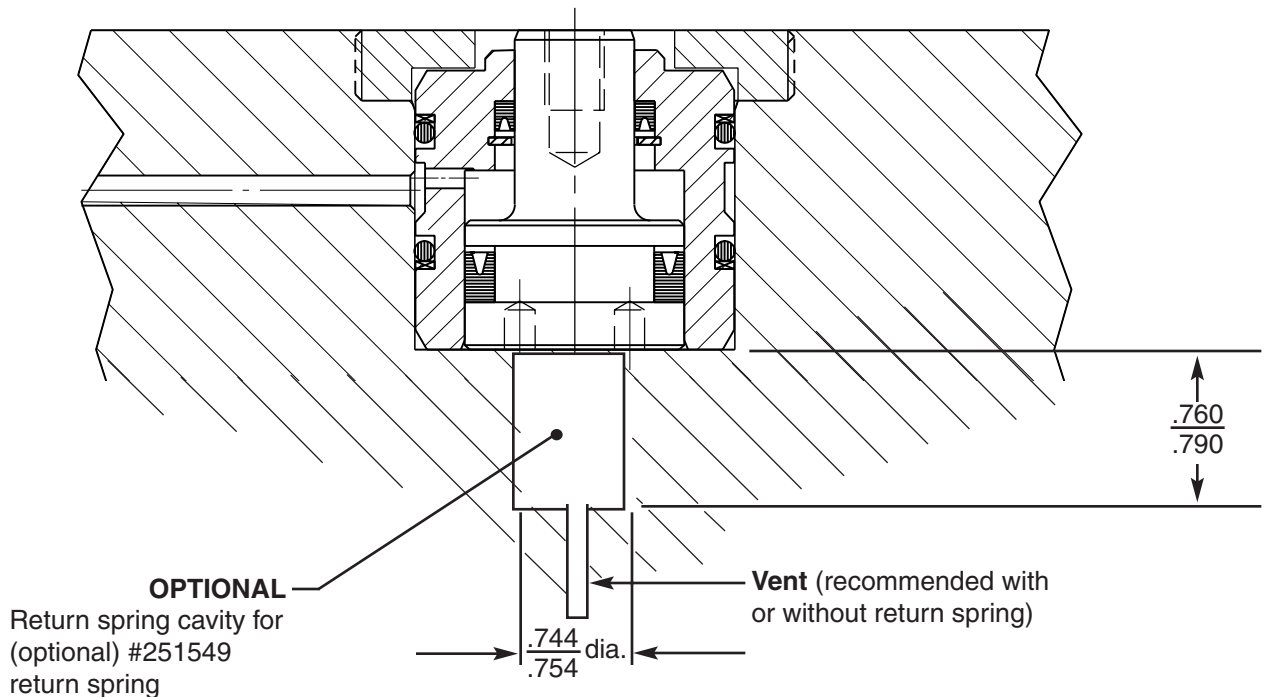

## BOTTOM MOUNTING SPECIFICATIONS

Mounting bores and oil supply passage dimensions for installation from cylinder base end:

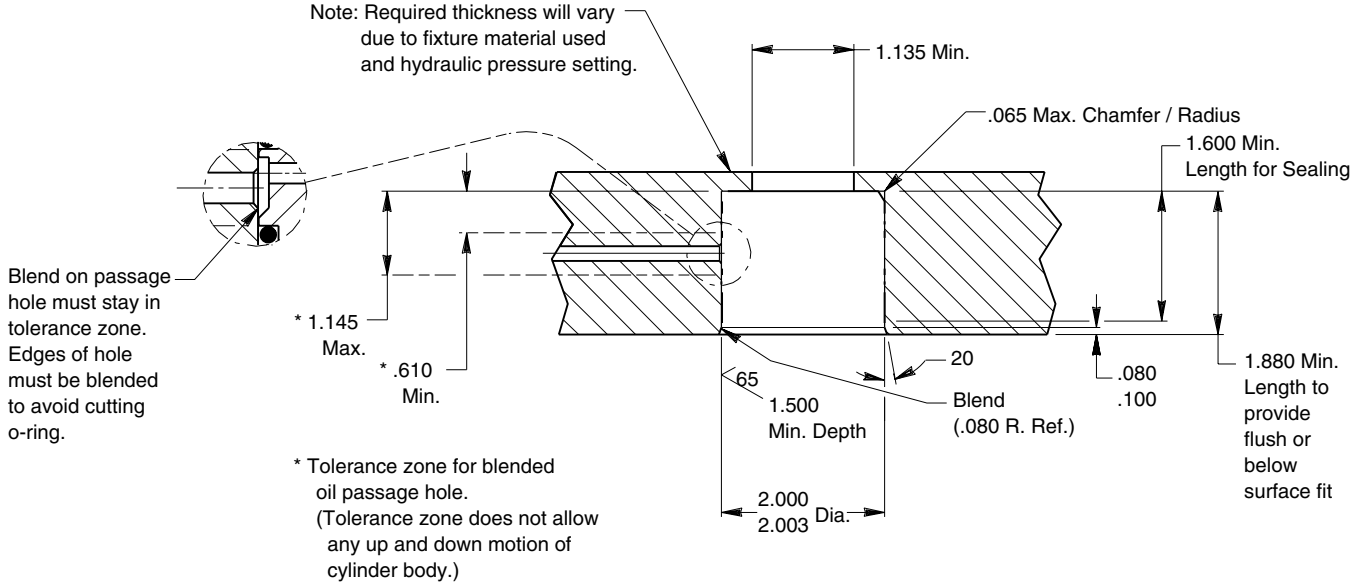

Cylinder in mounting cavity:

