

100963



Features

- Unique connector bushing provides positive mating with fixture, reducing the potential for leakage or weeping.
- Simple cavity design eliminates need for threaded holes in mating surfaces
- Manifold design eliminates external plumbing and reduces fixture height
- "Live Roller" design provides industry's most reliable swing/pull mechanism
 - o Piston/Cam combination provides solid path for clamping action
 - o Typical ball and groove mechanism has higher potential for clogging and for damage from mis-aligned work pieces

- Available in single and double acting versions
- Special rod wiper seal protects internal clamp components
- Unique drainage system channels contaminants away from clamp
- Heat treated, chrome plated piston rod
- Unique "Live Roller" swing mechanism for increased service life
- Power-Tech™ treated body and hardened cam for long wear and corrosion resistance
- Single and double-acting models
- Straight pull capacity 3,144 lbs. at 5,000 psi max.

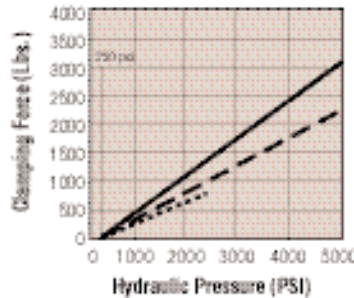

Performance
 Clamp Nos. 100895, 100896, 100897,
 100963, 100964, 100965

- With Hytec 500151 Arm (5.38" long)
- - - With Hytec 500150 Arm (2.00" long)
- Straight Pull

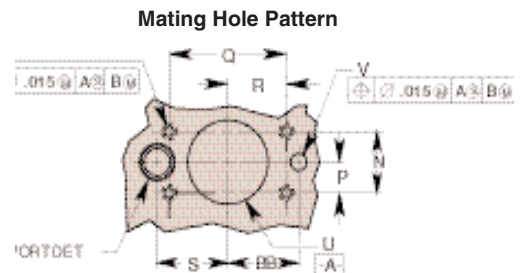
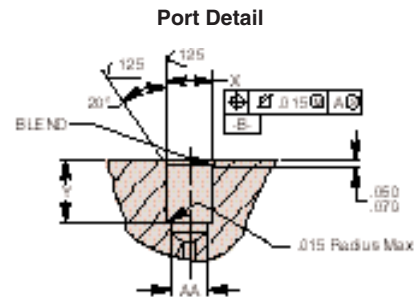
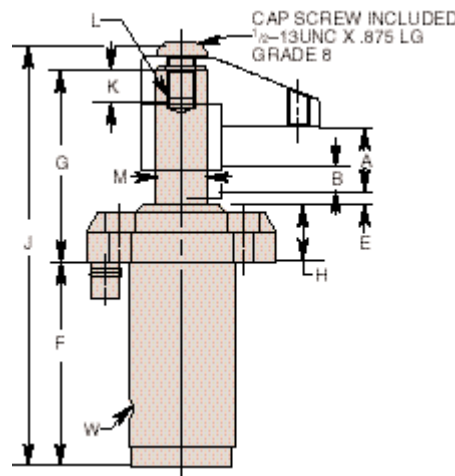
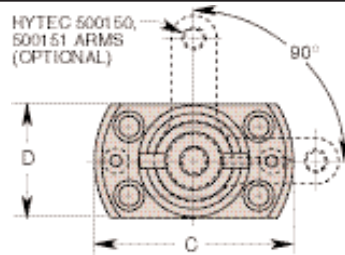

Cat. No.	Oper.	Specifications					Dimensions (In Inches)									
		Swing Direction	*Force (Lbs.)	Eff. Area (Sq. In.)		Oil Cap. (Cu. In.)		A Total Stroke	B Clamping Stroke	C Dia.	D	E	F	G	H	J
				Clamp	Unclamp	Clamp	Unclamp									
100895	Single-Acting	Left Hand (Counter Clockwise)	2,400	.626	-	.740	1.163	.490	3.257	1.860	.104	3.491	3.380	.995	7.311	
100896		Right Hand (Clockwise)														
100897		Straight Pull														
100963	Double-Acting	Left Hand (Counter Clockwise)	2,400	.626	1.227	.740	1.163	.490	3.257	1.860	.104	3.491	3.380	.995	7.311	
100964		Right Hand (Clockwise)														
100965		Straight Pull														

Cat. No.	Dimensions (In Inches)															
	K Thread Min.	L Thread Size	†† M Dia.	N Mounting	P Mounting	Q Mounting	R Mounting	S Mounting	T Thread Size	U Dia.	V Unclamp Port Dia. Max.	W	X Dia.	Y	AA Dia. Max.	BB Mounting
100895																
100896											-	†Vent				-
100897	.550	1/2-13 UNC	.875	1.125	.562	2.125	1.062	1.311	5/16-18 UNC	1.840	††.250	-	.500	.640	.481	1.311
100963										1.870			.503	.660		
100964																
100965																

NOTE: * With 2.00" long arm at 5,000 psi max. operating pressure.
 † Do not pressurize - single-acting only.
 †† See page 59 for custom arm mounting.
 Internal cam may be removed for an unguided straight pull.

See page 58 for maximum operating speeds and rotation options.
 †††Surface finish to be 63. Finish of 125 acceptable with concentric tool marks only. Finish area to be .500 DIA. min. centered on .250 DIA. port hole.
 See operating instructions for additional port details.