

Features:

- Manifold design eliminates external plumbing and reduces fixture height
- "Live Roller" design provides industry's most reliable swing/pull mechanism
 - o Piston/Cam combination provides solid path for clamping action
 - o Typical ball and groove mechanism has higher potential for clogging and for damage from mis-aligned work pieces
- Available in single and double acting versions
- Special rod wiper seal protects internal clamp components
- Unique drainage system channels

- contaminants away from clamp
- Corrosion resistant construction
- Heat treated, chrome plated piston rod
- Manifold mountable
- Unique "Live Roller" swing mechanism for increased service life
- Power-Tech™ treated body and hardened cam for long wear and corrosion resistance
- Single- and double-acting models are dimensionally interchangeable
- Straight pull cap. 3,144 lbs. at 5,000 psi max.
- Flange top or bottom mounting

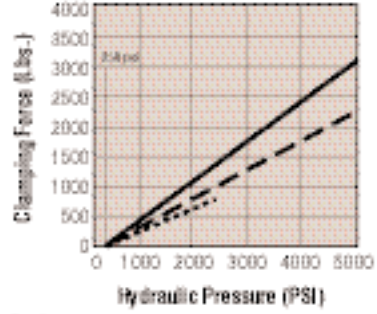
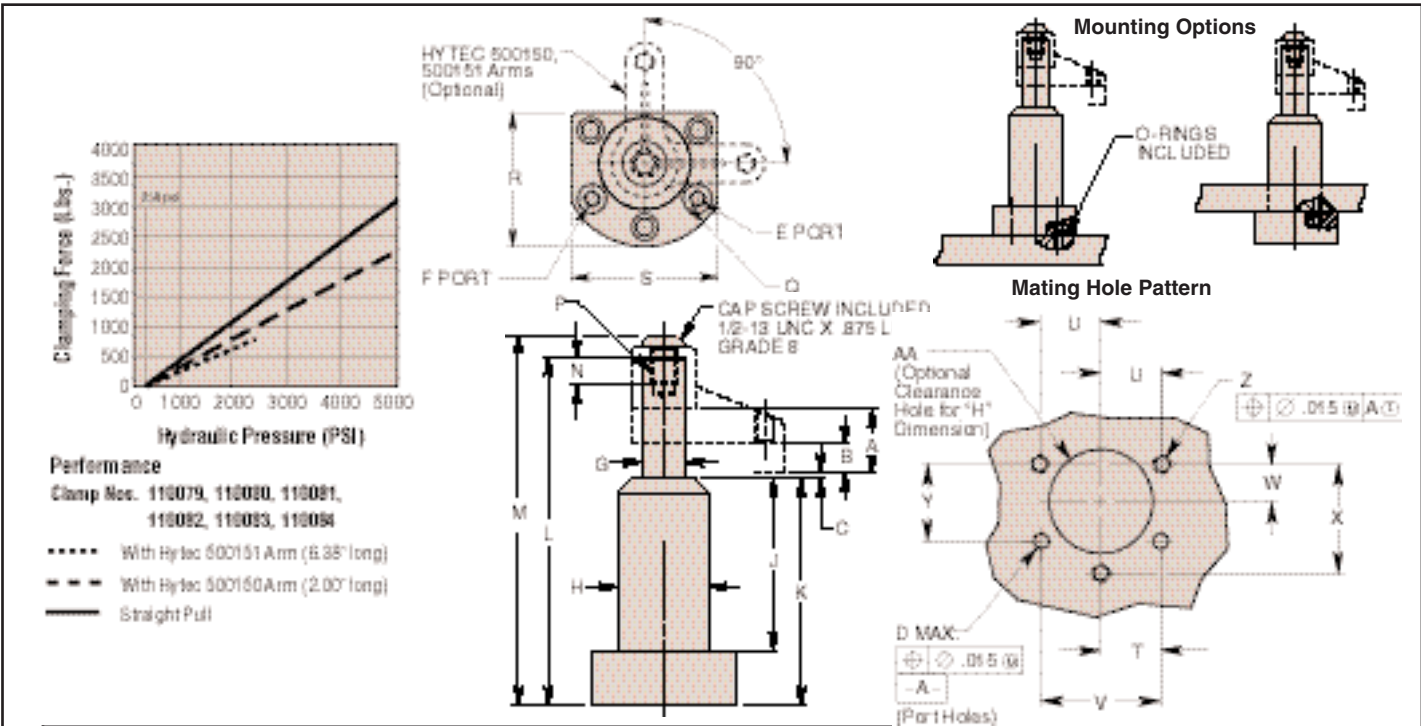

Performance
 Clamp Nos. 110079, 110080, 110081, 110082, 110083, 110084

..... With Hytec 500151 Arm (6.35" long)
 - - - - With Hytec 500150 Arm (2.00" long)
 ——— Straight Pull

Cat. No.	Specifications							Dimensions (In Inches)						
	Oper.	Swing Direction	*Force (Lbs.)	Eff. Area (Sq. In.)		Oil Cap. (Cu. In.)		A Total Stroke	B Clamping Stroke	C	††D Port Dia.	E Clamp Port	F Unclamp Port	††G Dia.
110079	Single-Acting	LH (Counter Clockwise)	2,400	.626	—	.740	1.163	.490	.104	.309 Max.	SAE O-Ring	†Vent	.875	1.807
110080		RH (Clockwise)												
110081		Straight Pull												
110082	Double-Acting	LH (Counter Clockwise)	1.227	1.460	—	—	—	—	—	—	—	—	—	—
110083		RH (Clockwise)												
110084		Straight Pull												

Cat. No.	Dimensions (In Inches)																
	J	K	L	M	N Thread Min.	*P Thread Size	Q Radius	R	S	T	U	V	W	X	Y	Z Thread Size	AA Dia.
110079	3.419	4.504	6.905	7.335	.550	½-13 UNC	1.630	2.630	2.880	1.024	1.082	2.048	.625	1.875	1.342	¾-18 UNC	1.830 1.850
110080																	
110081																	
110082																	
110083																	
110084																	

NOTE: * With 2.00" long arm at 5,000 psi max. operating pressure.
 † Do not pressurize - single-acting only.
 †† See page 59 for custom arm mounting. Internal cam may be removed for an unguided straight pull.
 See page 58 for maximum operating speeds and rotation options.
 ††† Surface finish to be 63. Finish of 125 acceptable with concentric tool marks only. Finish area to be .525 DIA. min. centered on .309 DIA. port hole. See operating instructions for additional port details.