



These electric/hydraulic pumps are two-stage, continuous pressure (demand) pumps that contain all the necessary controls and circuitry for powering any single- or double-acting continuous pressure workholding system. They have a pressure switch and an external pressure regulator, both infinitely adjustable throughout the operating pressure range of 1,000 to 5,000 psi. An internal safety relief valve prevents damage from exceeding the maximum rated pressure.

They are gerotor/axial piston pumps with a totally enclosed fan cooled (TEFC) induction motor. The 1/4" NPTF outlet manifold can be replaced by any Hytec pump-mounted valve. Shipped with two gallons of hydraulic oil.

Features:

- NEMA 12 electrical enclosure and controls
- CSA approved
- Drip/chip cover
- Liquid filled gauge
- Dual carrying handles
- Thermal overload protection
- 2.5-gallon metal reservoir
- 44 cu. in./min. oil flow at max. pressure
- 590 cu. in. usable oil

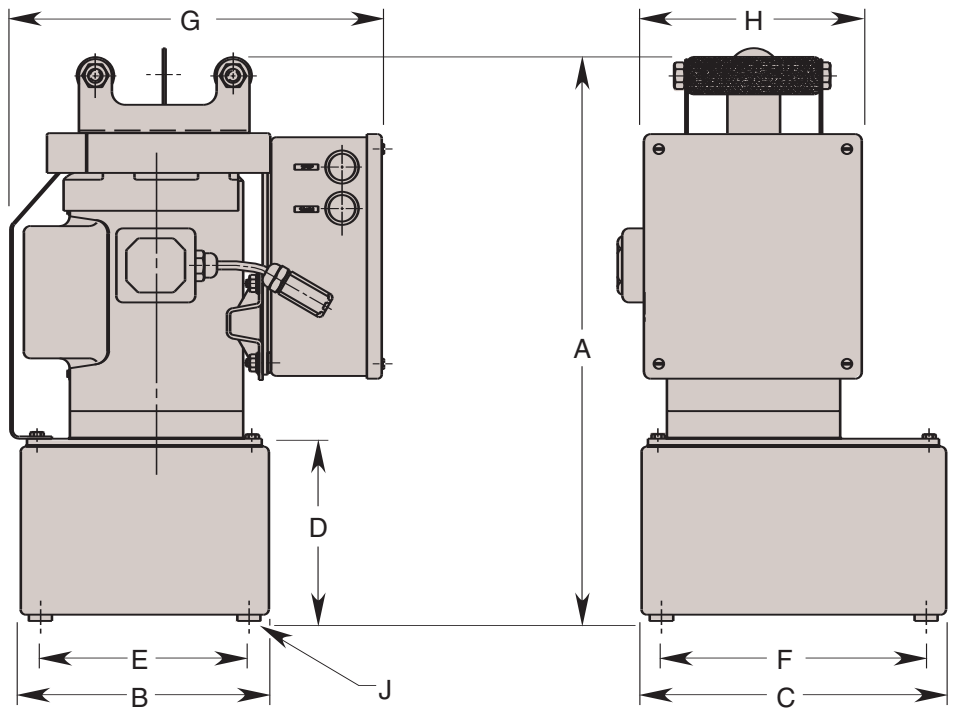
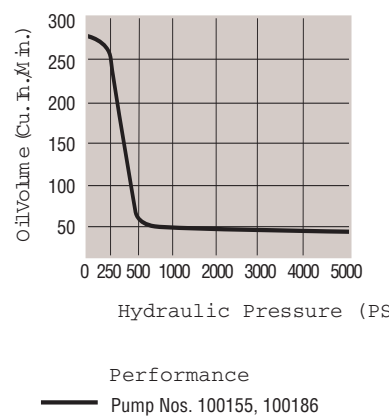

Cat. No.	Specifications			Dimensions (In Inches)								
	Electric Motor	Supply Voltage	Noise Level @ Idle/Max. Press. (dBA)	A	B	C	D	E	F	G	H	J Thread Size
100155	1 hp; 1,725 rpm; 230/460 VAC; 3.8/1.9 amps max.; 60 Hz; three phase	460 VAC	70	21.375	9.500	11.500	6.500	8.000	10.000	14.125	9.500	1/2-20 UNF
100155-230		230 VAC										
*100186	115 VAC											
100186-230	230 VAC											

NOTE: *For field conversion to 230 VAC, order conversion kit No. 250186. An optional fluid level / temperature gauge is available, see page 135.