

MODEL D ELECTRIC HYDRAULIC PUMP Maximum Capacity: 10,000 PSI

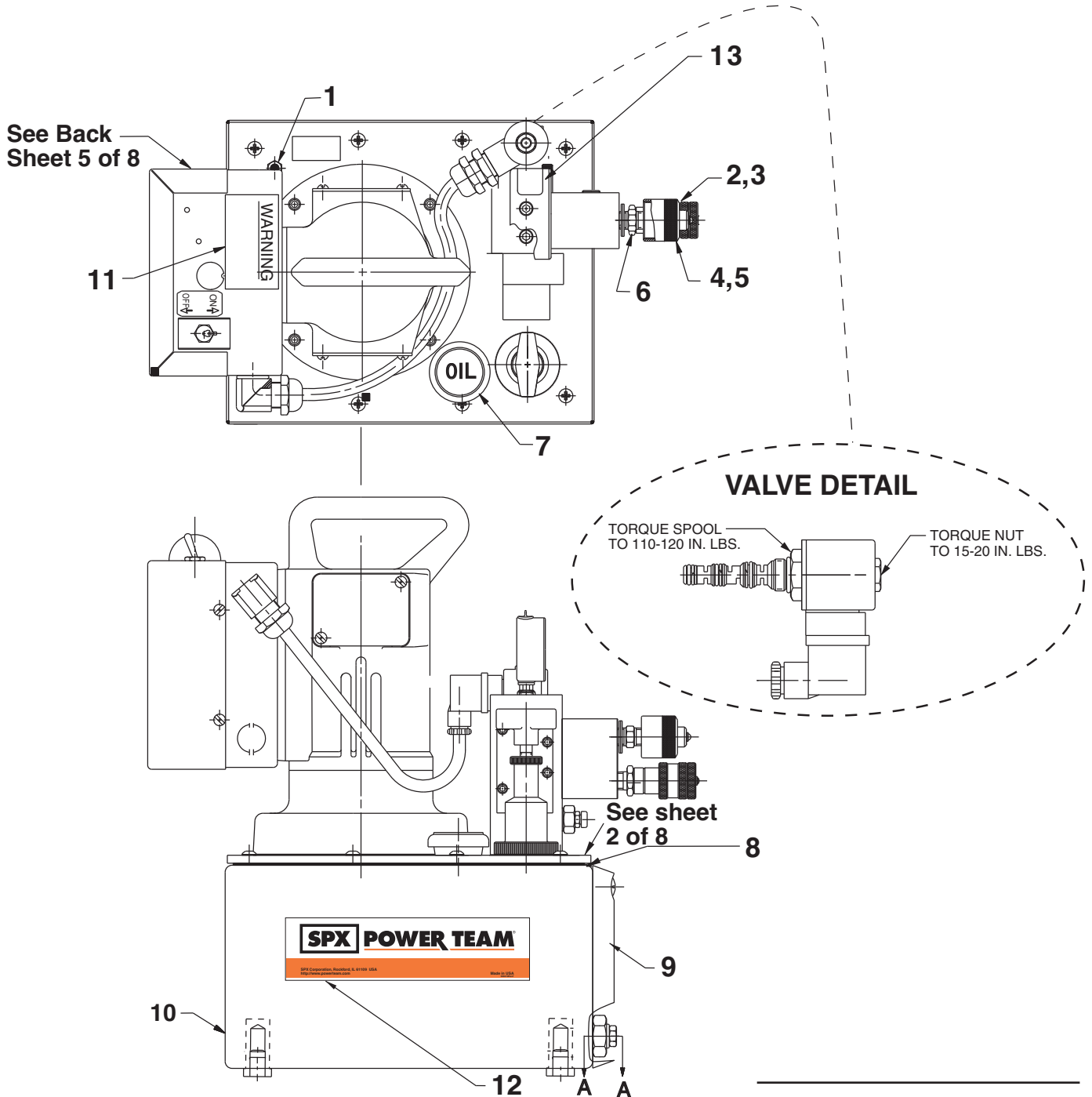

Item No.	Part No.	No. Req'd	Description
1	251599	1	Breather Filter Vent
2	*251410	1	Coupler
3	*252364	1	Dust Cap
4	*251411	1	Coupler
5	*252365	1	Dust Cap
6	*10672	1	Fitting
7	350925	1	Filler Cap
8	40164	1	Gasket
9	350431	1	Sight Gauge
10	65599OR9	1	Reservoir
11	250447	1	Warning Decal
12	309219	2	Decal, Tradename Power Team
13	9040	1	Gauge (10,000 psi 2-1/2" Dia.)

Part numbers marked with an asterisk are included with Valve Assembly 3000113.

SECTION A-A

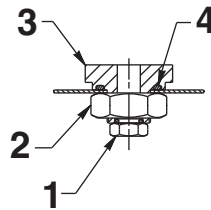

ALUMINUM RESERVOIR

Item No.	Part No.	No. Req'd	Description
1	17147	1	Plug Fitting
2	10396	1	Hex Jam Nut (3/4-16 UNF)
3	351000	1	Drain
4	14725	1	O-ring (1-1/8 x 15/16 x 3/32)

BASIC PUMP ASSEMBLY SIDE VIEW

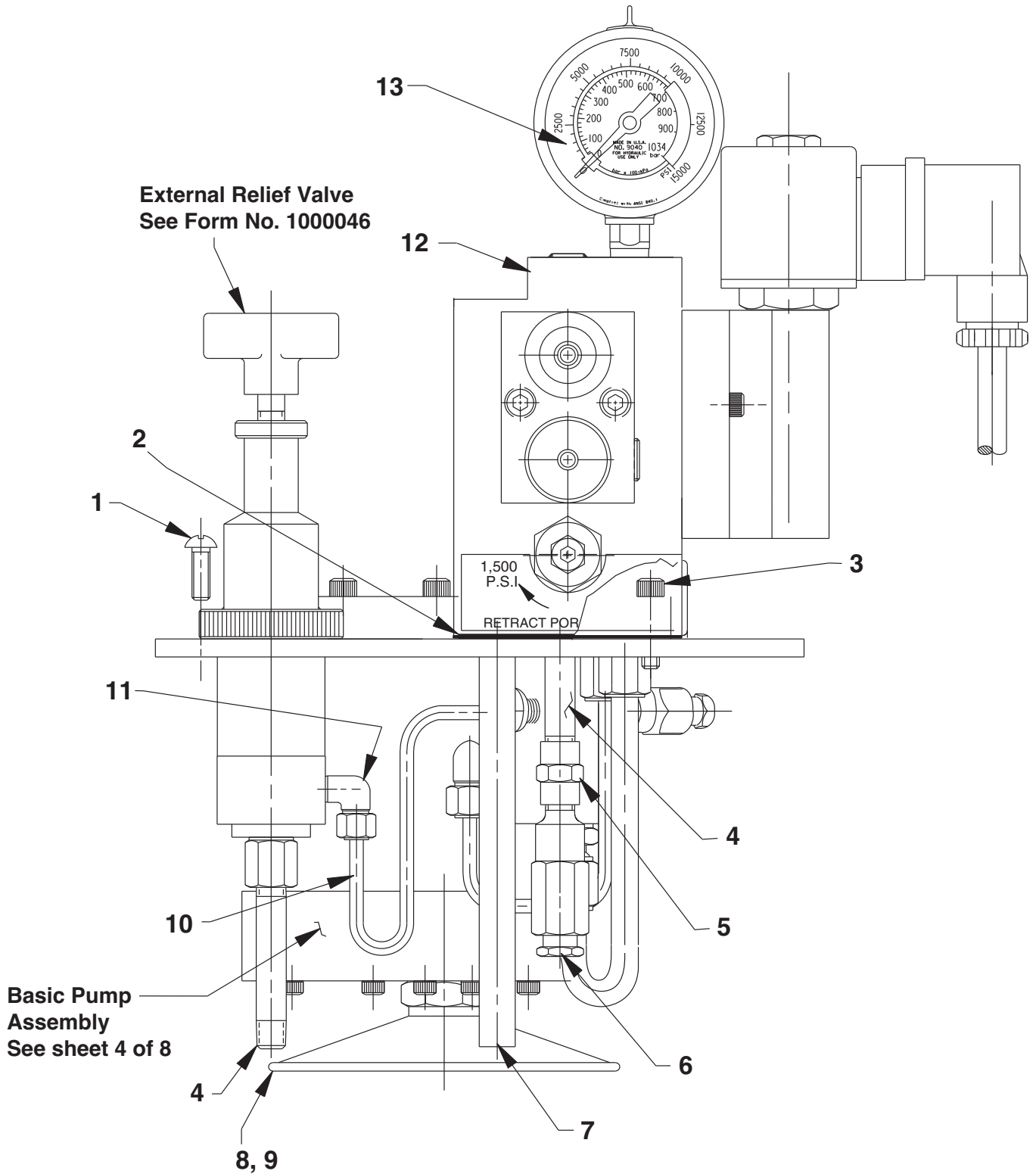

Item No.	Part No.	No. Req'd	Description
1	10177	10	Machine Screw (1/4-20 UNC X 3/4 Lg.)
2	351095	1	Gasket
3	10015	2	Cap Screw (1/4-28 UNF X 1" Lg.; Torque to 130/180 in. lbs.)
4	15456	2	Straight Fitting
5	18841	1	Pipe Connector
6	21278-15	1	Relief Valve Assembly (Set at 1,500/1,700 PSI)
7	200609	1	Drain Tube
8	21344	1	Filter Adapter (Includes o-ring [Item #9])
9	10300	1	O-ring (5/8 x 15/32 x 5/64)
10	252056	1	Oil Line Tube
11	16177	2	Tube Elbow
12	421293BK	1	Directional Valve Assembly (See Form No. 1000045)
13	9040	1	Gauge (10,000 psi - 2 1/2 Dia)

HYDRAULIC SCHEMATIC

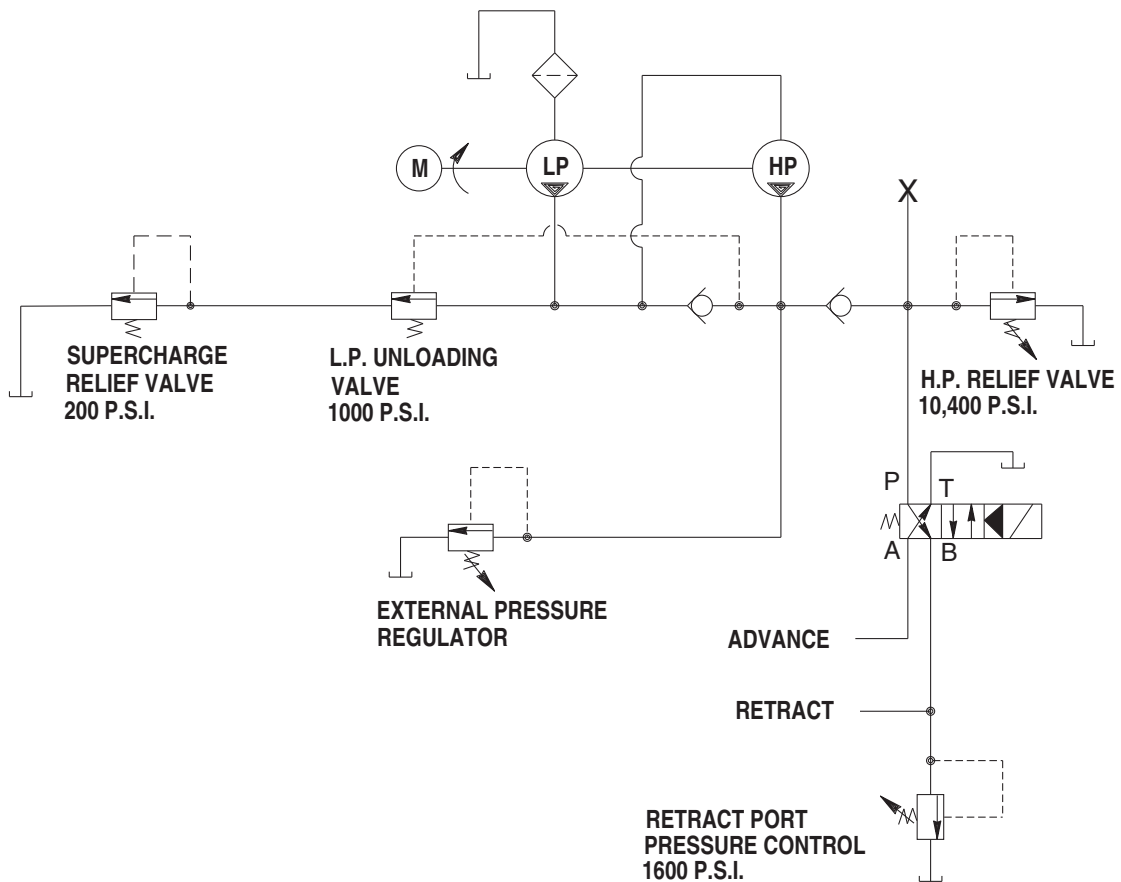

BASIC PUMP ASSEMBLY - BOTTOM VIEW

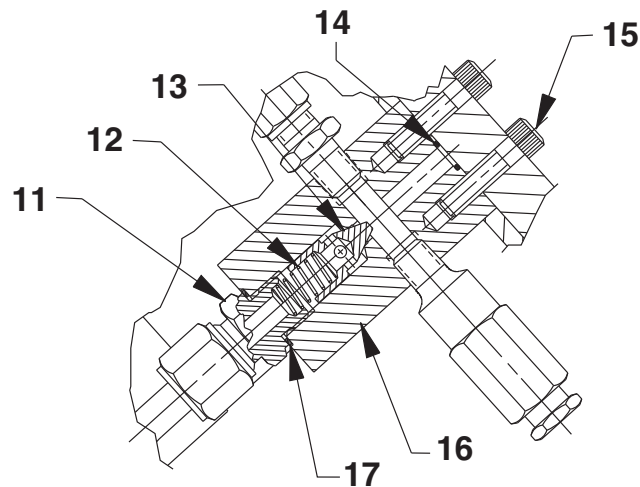
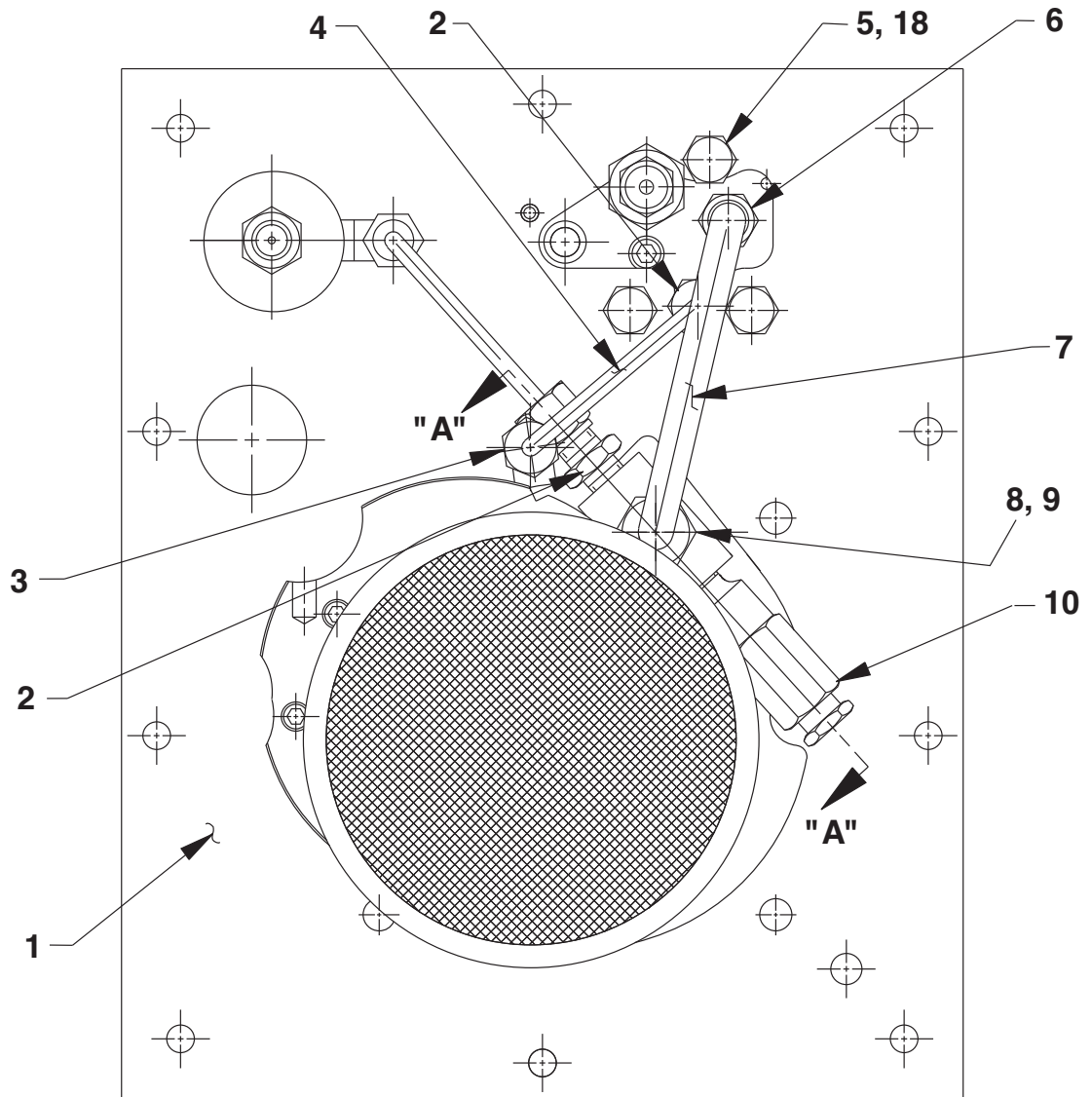

SECTION "A-A"

Parts List, Form No. 1000048, Back sheet 3 of 8

Item No.	Part No.	No. Req'd	Description
1	65043WH2	1	Cover Plate
2	14844	2	Connector
3	16177	2	Tube Elbow
4	252055	1	Oil Line Tube
5	10008	3	Cap Screw (1/4-20 UNC X 3/4 Lg.)
6	10661	1	Connector
7	351203	1	Oil Line Tube
8	10430	1	Tube Sleeve
9	10431	1	Tube Nut
10	21278	1	Relief Valve (Set at 10,100/10,700 PSI)
11	20770	1	Connector
12	10425	3	Compression Spring (3/8 O.D. X 3/4 Lg.)
13	20771	3	Poppet
14	10266	3	O-ring (3/8 X 1/4 X 1/16)
15	10015	2	Cap Screw (1/4-28 UNF X 1" Lg.)
16	20776	1	Valve Body
17	10261	1	Copper Washer (3/4 X 19/32 X 1/32)
18	10245	3	Washer

BASIC PUMP ASSEMBLY

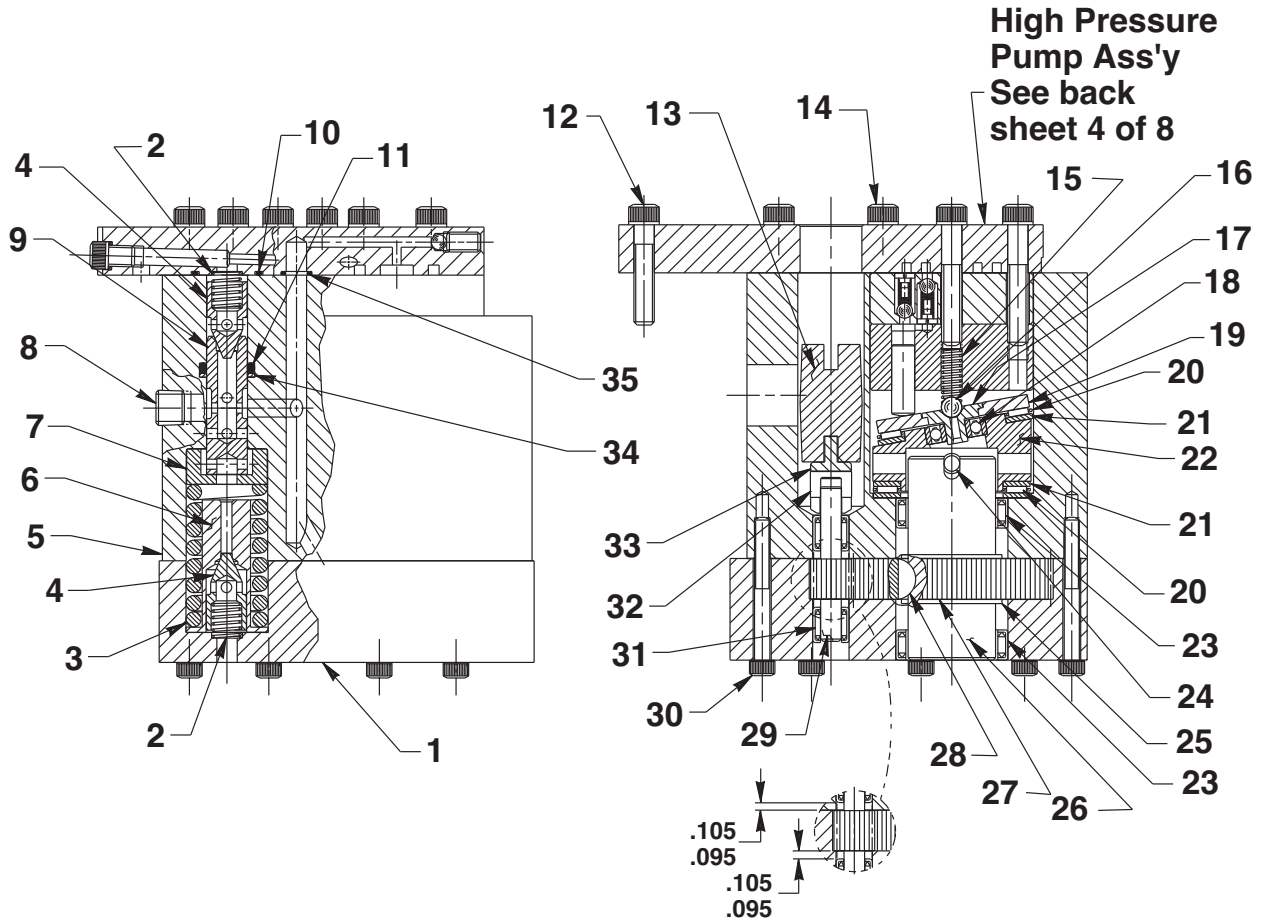

Item No.	Part No.	No. Req'd	Description
1	40072	1	End Plate
2	10425	2	Compression Spring (3/8 O.D. X 3/4 Lg.)
3	10426	1	Compression Spring (1" O.D. X 1-13/16" Lg.)
4	20771	2	Poppet
5	40071	1	Body
6	23256	1	Spring Guide
7	23255	1	Spring Guide
8	10427	1	Pressure Plug (1/8 NPTF)
9	20849	1	Spool
10	10303	1	O-ring (7/8 X 3/4 X 1/16)
11	10271	1	O-ring (11/16 X 1/2 X 3/32)
12	10016	3	Cap Screw (1/4-20 UNC X 1" Lg.)
13	21091	1	Coupling
14	10020	9	Cap Screw (1/4-20 UNC X 1-1/4 Lg.; Torque to 170/180 in. lbs.)
15	10361	1	Compression Spring (1/4 O.D. X 1" Lg.)
16	10375	1	Steel Ball (1/4 Dia.)
17	23547	1	Bearing Top Plate

Item No.	Part No.	No. Req'd	Description
18	11814	1	Ball Bearing
19	23548	1	Top Plate
20	11228	2	Thrust Bearing
21	11813	3	Bearing Race
22	23549	1	Angle Plate
23	11064	2	Needle Bearing
24	11955	1	Pin
25	11261	2	Retaining Ring
26	23556	1	Shaft
27	23574	1	Gear
28	11821	1	Woodruff Key
29	20774	1	Drive Gear
30	10001	13	Cap Screw (#10-32 UNF X 1-3/4" Lg.; Torque to 50/60 in. lbs.)
31	11198	2	Needle Bearing
32	21093	1	Key
33	21092	1	Adapter
34	12389	1	Backup Washer (11/16 x 1/2 X 1/16)
35	10266	1	O-ring (3/8 X 1/4 X 1/16)

HIGH PRESSURE PUMP ASSEMBLY

See Diagram
on Reverse
Side for
Important
Ass'y.
Information

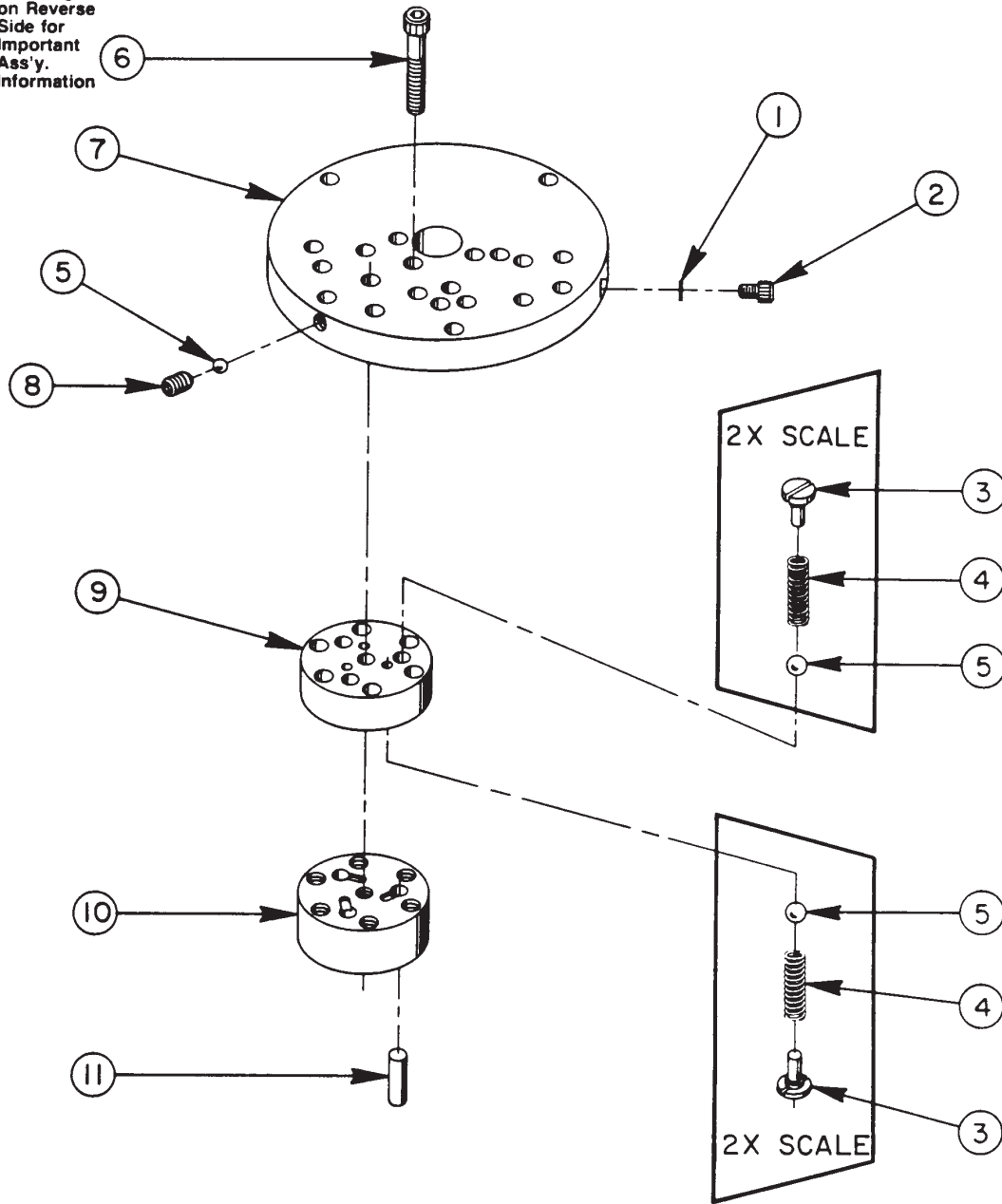

33113 HIGH PRESSURE PUMP ASSEMBLY

3 Pistons --- 9/32 Dia.

Item No.	Part No.	No. Req'd	Description
1	10442	1	Copper Washer
2	10002	1	Soc. Hd. Cap Screw (1/4-20 UNC X 3/8 Lg.; Torque to 140/160 in. lbs.)
3	*24549	6	Valve Guide
4	*10445	6	Compression Spring (5/32 O.D. X 3/4 Lg.)
5	*12223	7	Steel Ball (3/16 dia.)
6	*10023	7	Soc. Hd. Cap Screw (1/4-28 UNF X 1-1/2" Lg.; Torque to 170/180 in. lbs.)
7	*50411	1	Top Plate
8	10519	1	Soc. Set Screw (Torque to 65/70 in. lbs.)
9	*40630	1	Valve Head
10	*41062	1	Pump Barrel
11	*21628	3	Piston

Consult factory when replacing items marked with an asterisk (*).

BOLT TIGHTENING SEQUENCE

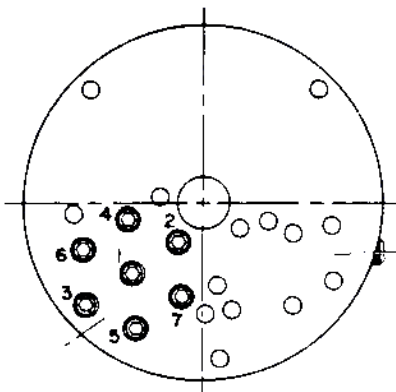

Note: Assemble in sequence shown.
Lubricate under head and on threads.
Torque to 170/180 in. lbs.

MOTOR CONTROL ASSEMBLY

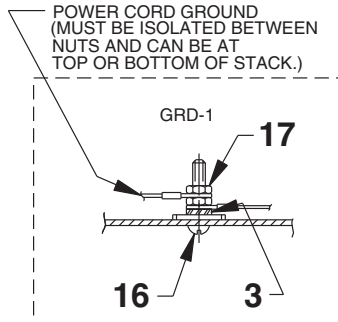

NOTE: SERRATED LOCK WASHER
MUST BE ADJACENT TO
METAL BOX. MORE WASHERS
CAN BE USED IF DESIRED.

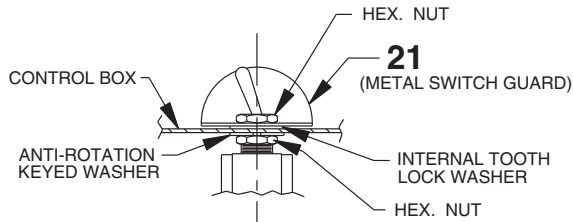
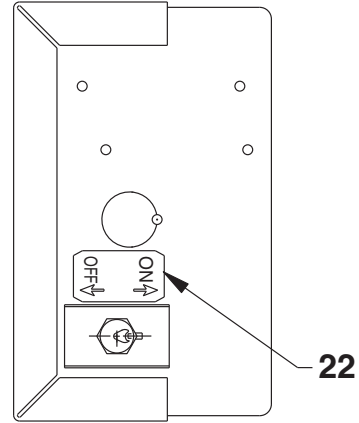
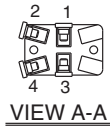

SWITCH DETAIL

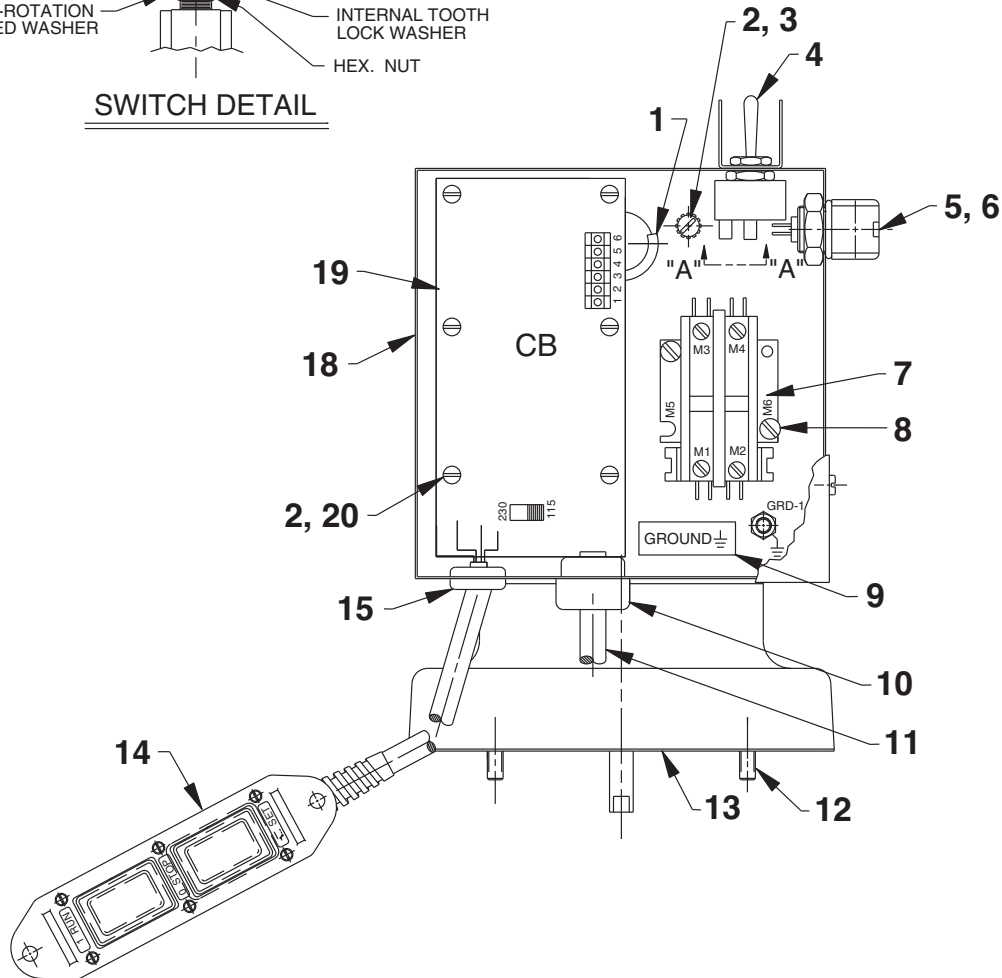

Item No.	Part No.	No. Req'd	Description
1	15497	1	Grommet (Trim off upper 1/3 as shown.)
2	10162	4	Machine Screw (#10-24 UNC X 1" Lg.)
3	11108	4	Lockwasher (#10 External Tooth)
4	12958	1	Toggle Switch
5	216667	1	Bushing
6	216680	1	Locknut
7	420718-1	1	Contactor (For 115 v.)
	420718-2	1	Contactor (For 230 v.)
8	11539	2	Machine Screw (#10-24 UNC X 1/2 Lg.)
9	205189	1	Ground Decal
10	210112	1	Strain Relief Bushing
11	307440	1	Cord Set (For 115 V.)
	308752	8 ft.	Electrical Cable (14/3 SJTO; For 230 V.)
12	10022	4	Screw (1/4-20 UNC X 1-1/2 Lg.)
13	30650	1	Gasket
14	351160	1	Hand Switch Assembly (See sheet 7 of 8)
15	15993	1	Strain Relief Bushing
16	11856	1	Machine Screw (#10-24 X 1" Lg.)
17	10197	2	Nut (#10-24 UNC)
18	51218WH2	1	Electric Control Box
19	421477	1	Circuit Board (Note: Set input voltage selector switch to appropriate position.)
20	10196	4	Hex Nut (8-32)
21	352061	1	Metal Switch Guard
22	205409	1	On/Off Label Decal

MOTOR & CONTROL BOX ASSEMBLY

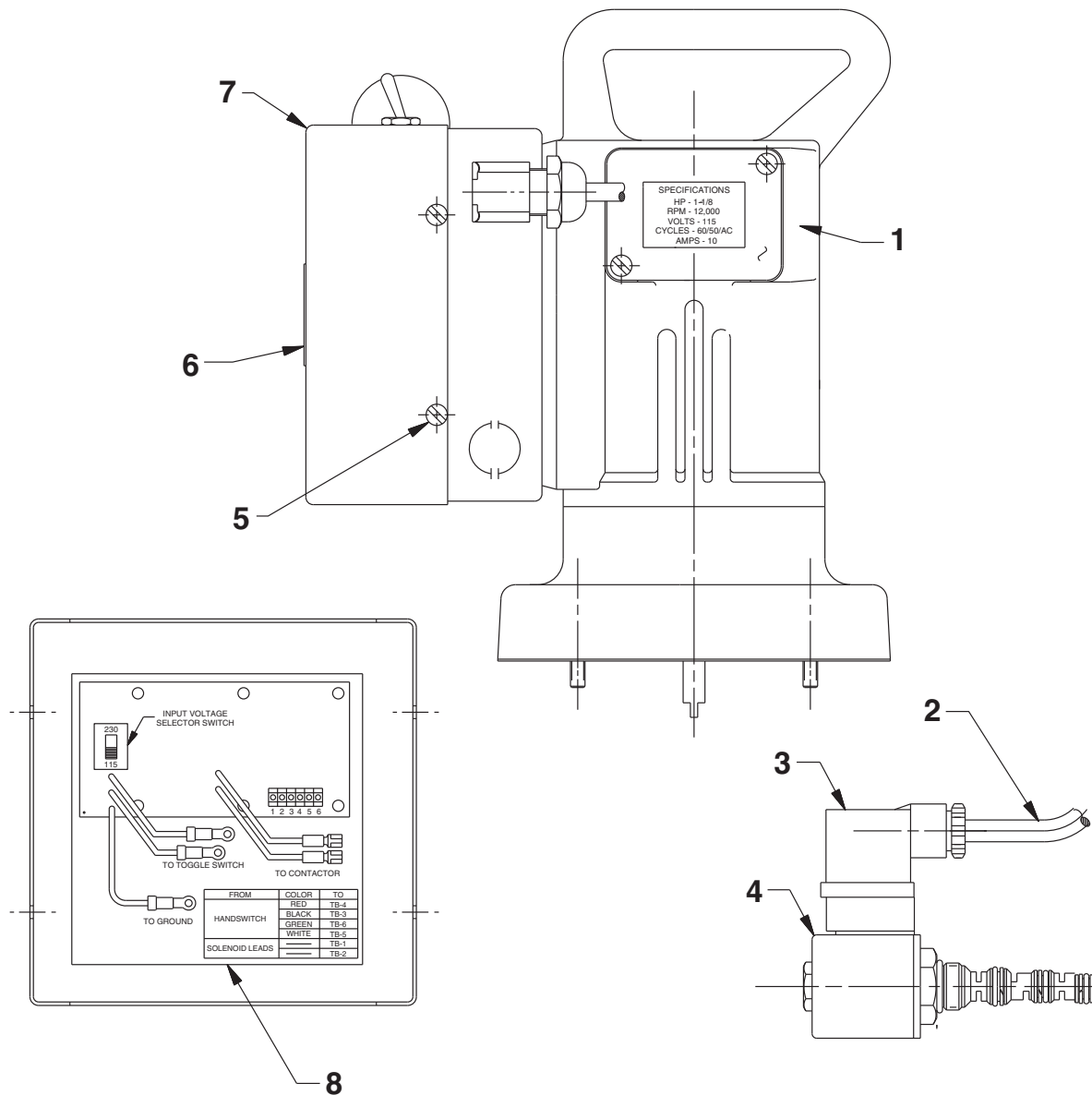

Item No.	Part No.	No. Req'd	Description
1	53338	1	Electric Motor (115 v.)
	53337	1	Electric Motor (230 v.)
2	11423	21"	Electrical Cable (18/2)
3	253405	1	Connector
4	351843	1	Solenoid Valve (115 v.)
	351844	1	Solenoid Valve (230 v.)

} See back sheet 7 of 8

Item No.	Part No.	No. Req'd	Description
5	14812	4	Tap Screw (#8-18 x 3/8 Lg.)
6	200188	1	Warning Decal
7	43126WH2	1	Electrical Control Box Cover
8	351513	1	Decal

REMOTE HAND SWITCH ASSEMBLY

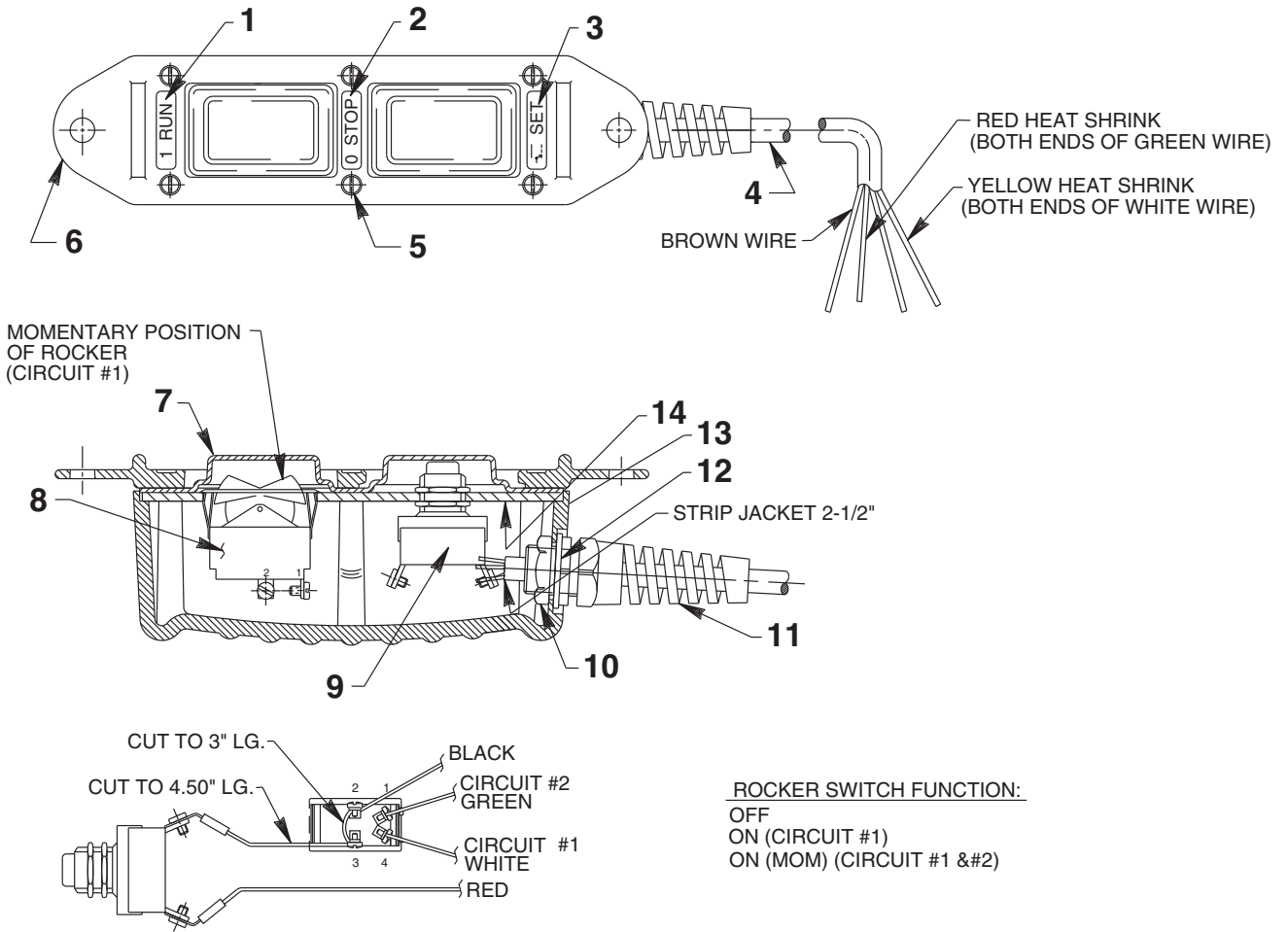

Item No.	Part No.	No. Req'd	Description
1	253105	1	Decal (Run)
2	253106	1	Decal (Stop)
3	253107	1	Decal (Set)
4	11391	21'	Cable (18/4 SJTO)
5	250248	6	Screw (4-24 X 3/4 Lg.)
6	251044	1	Plastic Cover
7	420050-2	1	Gasket

Item No.	Part No.	No. Req'd	Description
8	420017	1	Rocker Switch
9	253197	1	Push Button Switch
10	251802	1	Locknut
11	251818	1	Strain Relief Bushing
12	253607	1	Gasket
13	420050-4	1	Switch Housing
14	420050-5	1	Switch Mounting Plate

MOTOR ASSEMBLY

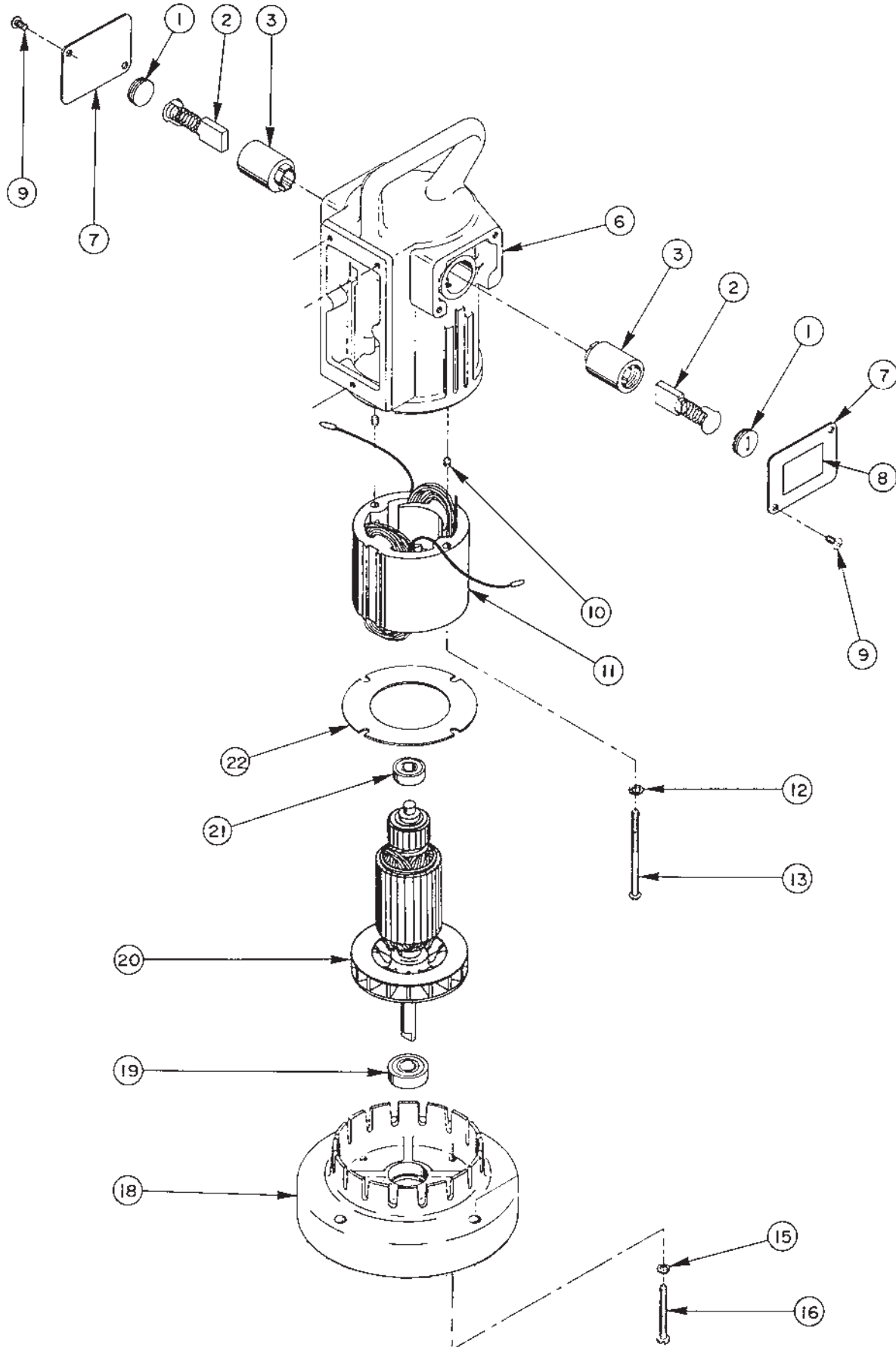

Item No.	Part No.	No. Req'd	Description
1	10806	2	Brush Holder Cap
2	10804	2	Brush Assembly
3	10805	2	Brush Holder (See note below)
6	61901WH2	1	Motor Shell
7	21008	2	Cover
8	215164	1	Spec. Decal (For 115 v)
	215163	1	Spec. Decal (For 230 v.)
9	11539	2	Mach. Screw (#10-24 X 1/4 Lg.)
10	10133	2	Set Screw
11	10802	1	Field (For 115 v.)
	252311*	1	Field (For 230 v.)
12	12356	2	Lockwasher
13	10170	2	Mach. Screw
15	10241	4	Lockwasher
16	10169	4	Mach. Screw (#10-24 X 2" Lg.; Torque to 20/25 in lbs.)
18	40059WH2	1	Motor Base
19	10439	1	Ball Bearing
20	10800	1	Armature (For 115 v.; See note below)
	252311*	1	Armature (For 230 v.; See note below)
21	10438	1	Ball Bearing
22	20786	1	Baffle Plate

* **Note** 252311 is a kit containing both armature and field. 230VAC motors needing either a new field or armature must have both replaced as a set as they are not interchangeable.

BRUSH HOLDER & ARMATURE INSTALLATION SPECIFICATIONS

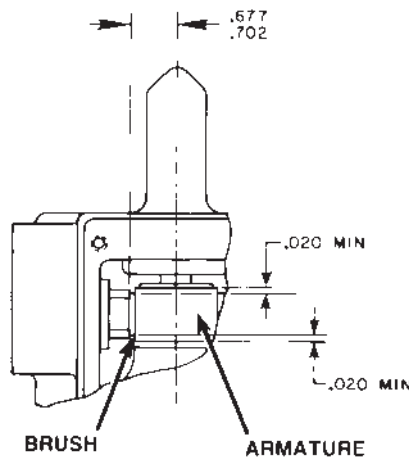

When replacing brushes or the armature, the dimensions shown must be as specified.

**RECOMMENDED MINIMUM WIRE SIZE-AWG (mm²)
OF EXTENSION CORDS FOR
POWER TEAM ELECTRIC PUMPS**

Current At Full Load (Amps)	Cord Size AWG (mm ²) 3.2 Volt Drop			
	Length of Cord			
	0-25 feet (0-8 m)	25-50 feet (8-15 m)	50-100 feet (15-30 m)	100-150 feet (30-45 m)
6	18 (.82)	16 (1.33)	14 (2.09)	12 (3.32)
8	18 (.82)	16 (1.33)	12 (3.32)	10 (5.37)
10	18 (.82)	14 (2.09)	12 (3.32)	10 (5.37)
12	16 (1.33)	14 (2.09)	10 (5.37)	8 (8.37)
14	16 (1.33)	12 (3.32)	10 (5.37)	8 (8.37)
16	16 (1.33)	12 (3.32)	10 (5.37)	8 (8.37)
18	14 (2.09)	12 (3.32)	8 (8.37)	8 (8.37)
20	14 (2.09)	12 (3.32)	8 (8.37)	6 (13.30)
22	14 (2.09)	10 (5.37)	8 (8.37)	6 (13.30)
24	14 (2.09)	10 (5.37)	8 (8.37)	6 (13.30)
26	12 (3.32)	10 (5.37)	8 (8.37)	6 (13.30)
28	12 (3.32)	10 (5.37)	6 (13.30)	4 (21.29)
30	12 (3.32)	10 (5.37)	6 (13.30)	4 (21.29)