

Parts List and Operating Instructions for:



PB102	PB102P	PB102-CP
PB102-0	PB102P-0	PB104
PB102-1	PB102P-1	PB104-0
PB102-2	PB102P-2	PB104-1
PB102A	PB102R	PB104-2
PB102A-0	PB102R-0	
PB102A-1	PB102R-1	
PB102A-2	PB102R-2	

## BATTERY POWERED HYDRAULIC PUMP



# TABLE OF CONTENTS

---

<b>SAFETY SYMBOLS AND DEFINITIONS</b>	<b>4</b>
<b>SAFETY PRECAUTIONS</b>	<b>4</b>
General	5
Power Supply	6
Hydraulic Hoses and Lines	6
Pump	7
Hydraulic Fluids	7
<b>DESCRIPTION</b>	<b>8</b>
<b>SETUP INSTRUCTIONS</b>	<b>10</b>
1. Hydraulic Connections.	10
2. Checking Hydraulic Fluid and Filling the Bladder.	10
3. Hydraulic Lines and Fittings.	11
4. 18VDC Battery & Charger	11
5. Bleeding The System	13
<b>PUMP OPERATION</b>	<b>14</b>
1. Operating The Pump For The First Time.	14
2. Attaching And Operating Hand Pendant	14
3. Lifting or lowering a load with a hydraulic cylinder.	16
<b>DIRECTIONAL CONTROL VALVE OPTIONS</b>	<b>17</b>
1. 2-Way Manifold	17
2. 2-Position, 2-Way Manual Valve	18
3. 3-Position, 4-Way Manual Valve	19
<b>ADJUSTING THE PRESSURE REGULATING CONTROLS</b>	<b>21</b>
1. Adjusting The Pressure Regulating Valve	21
<b>PREVENTIVE MAINTENANCE</b>	<b>22</b>
1. Checking Hydraulic Fluid and Filling the Bladder	22
2. Maintenance Cleaning	23
3. Draining and Cleaning the Bladder	23
<b>TROUBLESHOOTING GUIDE</b>	<b>23</b>
<b>PARTS LIST</b>	<b>27</b>
PB10 Series Hydraulic Pump	27
65187-18 (Pump Sub-assembly, Electric 18VDC)	30
350622 (Valve, Manual, 2-Position 2-Way)	34
420558 (Valve, Manual, 3-Position 4-Way)	35
350623 (Body, Valve Pressure Regulator)	37
350720 (Manifold Assembly)	39
3001123 (Manifold Assembly)	40

**Table of contents continued**

---

<b>ELECTRICAL SCHEMATIC</b>	<b>41</b>
<b>HYDRAULIC SCHEMATIC</b>	<b>42</b>
<b>POWER TEAM FACILITIES &amp; CONTACT</b>	<b>43</b>
<b>MILWAUKEE ELECTRIC TOOL CORPORATION CONTACT</b>	<b>43</b>
<b>EC DECLARATION OF CONFORMITY</b>	<b>44</b>

# SAFETY SYMBOLS AND DEFINITIONS

---

The safety signal word designates the degree or level of hazard seriousness.

 **DANGER**: Indicates an imminently hazardous situation which, if not avoided, will result in death or serious injury.

 **WARNING**: Indicates a potentially hazardous situation which, if not avoided, could result in death or serious injury.

 **CAUTION**: Indicates a potentially hazardous situation which, if not avoided, may result in minor or moderate injury.

**CAUTION**: Used without the safety alert symbol indicates a potentially hazardous situation which, if not avoided, may result in property damage.

**IMPORTANT**: Important is used when action or lack of action can cause equipment failure, either immediate or over a long period of time.

## SAFETY PRECAUTIONS

---

 **WARNING** The following procedures must be performed by qualified, trained personnel who are familiar with assembling this equipment.



- Operators/installers must read and understand all safety precautions and operating instructions included with the pump. If the operator cannot read these instructions, operating instructions and safety precautions must be read and discussed in the operator's/ installer's native language.
- These products are designed for general use in normal environments. These products are not designed for lifting and moving people, agri-food machinery, certain types of mobile machinery, or in special work environments such as: explosive, flammable, or corrosive. Only the user can decide the suitability of this product in these conditions or extreme environments. Power Team will supply information necessary to help make these decisions. Consult your nearest Power Team facility.



- Safety glasses must be worn at all times by the operator and anyone within sight of the unit. Additional personal protection equipment may include: face shield, goggles, gloves, apron, hard hat, safety shoes, and hearing protection.
- The owner of this tool must ensure that safety-related decals are installed, maintained, and replaced if they become hard to read.
- Disconnect the battery from the pump and relieve pressure before opening any connections in the system.
- The guide cannot cover every hazard or situation so always do the job with **SAFETY FIRST**.

### General

**⚠ WARNING** To reduce the risk of fire, personal injury, and product damage due to a short circuit, never immerse your tool, battery pack or charger in fluid or allow a fluid to flow inside them. Corrosive or conductive fluids, such as seawater, certain industrial chemicals, and bleach or bleach containing products, etc., can cause a short circuit.



- This unit is not suitable for use in explosive environments. Failure to comply may result in damage, injury, or death.



- Always wear eye protection whenever operating hydraulic equipment.



- Always wear hearing protection as required. Refer to the sound level (dB[A]) chart.

- Operation, repair, or maintenance of hydraulic equipment should be performed by a qualified person who understands the proper function of hydraulic equipment per local directives and standards.

- Hydraulic equipment must be assembled correctly and then checked for proper function before use. Use hydraulic components of the same hydraulic pressure ratings. An appropriate hydraulic pressure gauge is recommended to monitor pressure.



- Never place your hands or other body parts near a hydraulic fluid leak. Never use your hands or other body parts to check for a possible leak. High pressure fluid can be injected under your skin causing serious injury and/or infection.

- High pressure fluid is present throughout a hydraulic system. Always use caution when operating, repairing, or maintaining this equipment. Before beginning any work on any hydraulic system component, stop the equipment, disconnect from its power source, and relieve all pressure in all parts of the system. Do not tamper with the internal hydraulic relief valve settings.

- Avoid exposing hydraulic equipment (especially hoses) to extreme high or low temperatures. Damage to equipment or failure may result and cause loss of control or injury to the operator.



- Exercise caution to avoid the risk of fire.

- Do not drop any hydraulic system components. Damage to the equipment and/or injury may result.

- Avoid slipping or falling by cleaning up any oil spills.

- Avoid back injury by always lifting equipment carefully.

- It is strongly recommended to view the Power Team Hydraulic Safety video tape before using hydraulic equipment.

### Power supply



- **Electrical Shock or Electrocution.**
- **Any electrical work must be done and tested by a qualified electrician per local directives and standards.**
- **Disconnect the battery from the pump and relieve pressure before removing the motor case cover or performing maintenance or repair.**
- **If wiring is exposed, replace or repair immediately.**
- **Do not attempt to increase the power capacity by replacing a fuse with another fuse of higher value. Overheating of the power supply and the possibility of a fire will result.**
- **Electric pumps should never be exposed to rain or water which could cause personal electrical hazard.**
- **Avoid conditions which can cause damage to the power supply such as abrasion, crushing, sharp cutting edges, or corrosive environment. Damage to the power supply can cause an electrical hazard.**

### Hydraulic hoses and lines

- **Avoid straight line tubing connections in short runs. Straight line runs do not provide for expansion and contraction due to pressure and/or temperature changes. See diagrams in “Set-up Instructions” section of this form.**
- **Eliminate stress in the tube lines. Long tubing runs should be supported by brackets or clips. Tubes through bulkheads must have bulkhead fittings. This makes easy removal possible and helps support the tubing.**
- **Before operating the pump, all hose connections must be tightened with the proper tools. Do not overtighten. Connections should only be tightened securely and leak-free. Overtightening can cause premature thread failure or high pressure fittings to split at pressures lower than their rated capacities.**
- **Should a hydraulic hose ever rupture, burst, or need to be disconnected, immediately shut off the pump and release all pressure. Never attempt to grasp a leaking pressurized hose with your hands. The force of escaping hydraulic fluid could cause serious injury.**
- **Do not subject the hose to potential hazard such as fire, sharp surfaces, extreme heat or cold, or heavy impact. Do not allow the hose to kink, twist, curl, crush, cut, or bend so tightly that the fluid flow within the hose is blocked or reduced. Periodically inspect the hose for wear, because any of these conditions can damage the hose and possibly result in personal injury. Never repair with tape.**



- **Do not use the hose to move attached equipment. Stress can damage the hose and possibly cause personal injury.**
- **Hose material and coupler seals must be compatible with the hydraulic fluid used. Hoses also must not come in contact with corrosive materials such as creosote-impregnated objects and some paints. Hose deterioration due to corrosive materials can result in personal injury. Consult the manufacturer before painting a hose. Never paint a coupler.**

### Pump

- Do not exceed the hydraulic pressure rating noted on the pump nameplate or tamper with the internal high pressure relief valve. Creating pressure beyond rated capacities can result in personal injury.
- Before replenishing the fluid level, retract the system to prevent overfilling the pump reservoir or bladder. An overfill can cause personal injury due to excess reservoir or bladder pressure created when accessories are retracted.
- Always shut off the motor and/or disconnect power supply and relieve pressure before breaking any connections in the system.
- The motor is the major part of the weight of the pump. Always take this into consideration when lifting or moving the pump.

### Hydraulic fluids

- Properly dispose of all fluids, components, and assemblies at the end of their useful life.
- Hydraulic fluid should be compatible with all hydraulic components.

# DESCRIPTION

- The PB10 Series hydraulic pump delivers hydraulic fluid under pressure through the use of an electric motor and 18VDC Li-ION battery as a power source.

<b>PUMP SPECIFICATIONS</b>				
Pump Cat. No.	Max. Operating Pressure	Features	Kw	 <b>dB(A)</b> Idle / 700 Bar
PB102-0 * PB102-1 PB102-2 **	10,152 PSI 700 Bar	2P2W Valve	.144	65/72
PB102P-0 * PB102P-1 PB102P-2 **	10,152 PSI 700 Bar	2P2W Valve & Hand Pendant	.144	65/72
PB102R-0 * PB102R-1 PB102R-2 **	10,152 PSI 700 Bar	2P2W Valve & Pressure Regulator	.144	65/72
PB102A-0 * PB102A-1 PB102A-2 **	10,152 PSI 700 Bar	2W Manifold	.144	65/72
PB102-CP	10,152 PSI 700 Bar	2W Manifold w/ 10K PSI Pop-off Relief Valve	.144	65/72
PB104-0 * PB104-1 PB104-2 **	10,152 PSI 700 Bar	3P4W Valve	.144	65/72

\* Models designated with (-0) do not include battery charger.

\*\* Models designated with (-2) include a 220-240V battery charger.

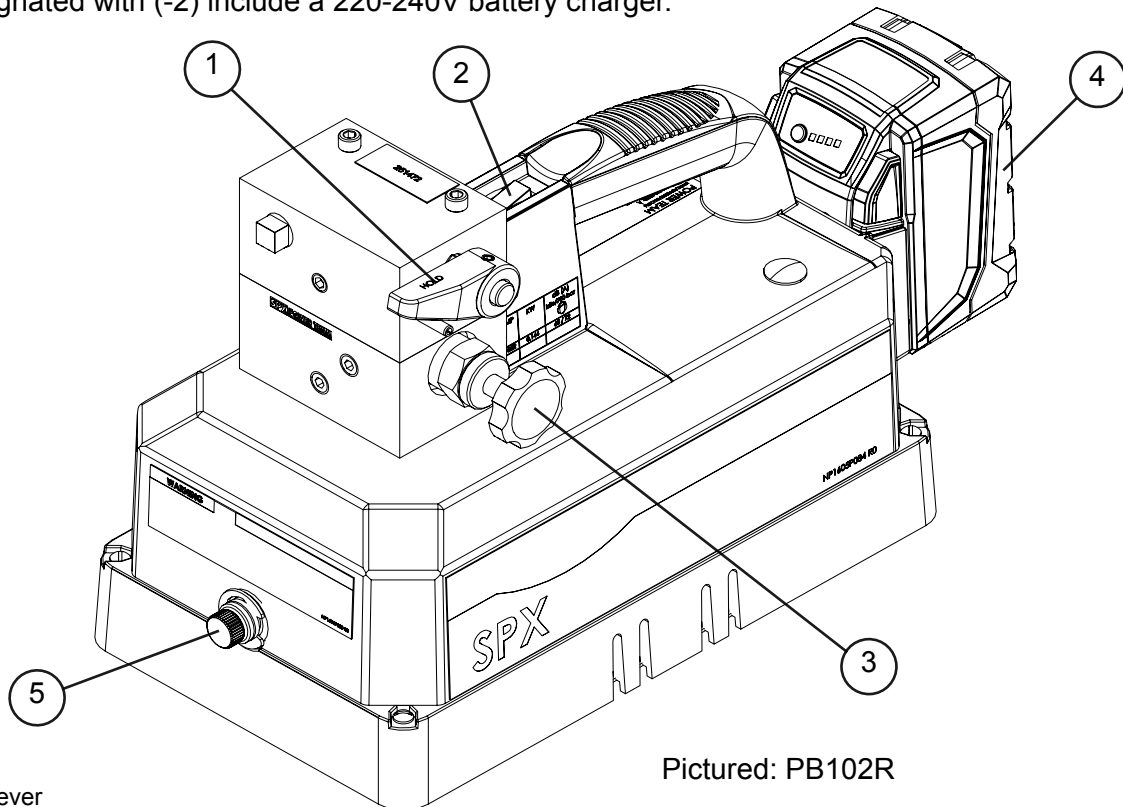

Pictured: PB102R

- |                                       |                          |
|---------------------------------------|--------------------------|
| 1. Valve control lever                | 4. Battery Pack          |
| 2. Start button                       | 5. Oil Bladder Fill Port |
| 3. Pressure regulator adjustment knob |                          |



Description continued

## BATTERY & CHARGER SPECIFICATIONS

(Excerpt from Milwaukee Tool operator's manuals)

Charger SPX Cat. No.	AC Input Volts	AC Input Amps	DC Output Volts	DC Output Amps	Battery SPX Cat. No.	DC Volts
2009646	110-120	2.1	12 or 18V	3	3000973	18
2009647	220-240	1.15	12 or 18V	3		

### SYMBOLOLOGY

<b>V</b>	Volts Direct Current
<b>V</b>	Volts Alternating Current
	Double Insulated
<b>Hz</b>	Hertz

### FUNCTIONAL DESCRIPTION

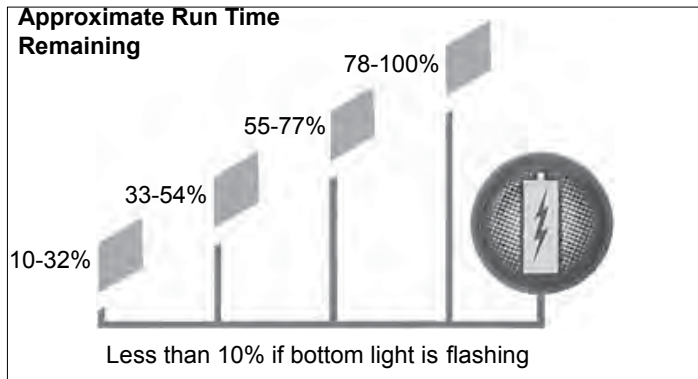
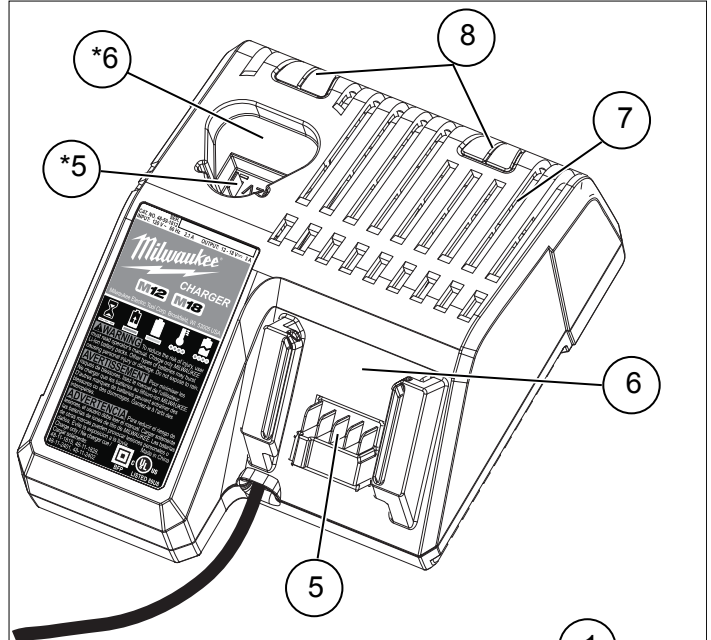

**IMPORTANT:** For information regarding care, use, recycling, or warranty of batteries and/or chargers, contact Milwaukee Electric Tool Corporation or see original manufacturers operating manual.

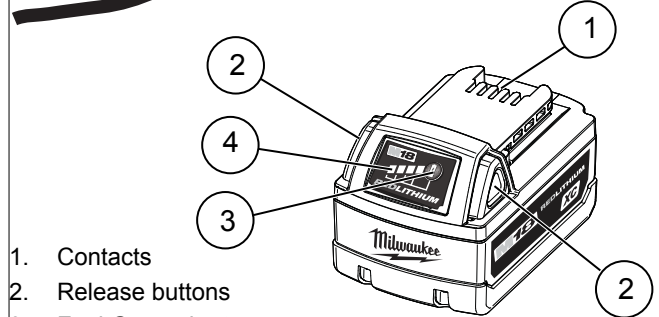

1. Contacts
2. Release buttons
3. Fuel Gauge button
4. Fuel Gauge
5. Electrical contacts
6. Bay
7. Vents
8. Light indicators:



Continuous red: Charging



Continuous Green: Charging is complete



Fast flashing red: Battery is too hot/cold - Charging will begin when battery reaches correct charging temperature



\*\* Slow flashing red: Battery charge is pending - Charging will begin when first pack is fully charged.



Flashing red/green: Damaged or faulty battery pack

\* Items only on multi voltage charger models

\*\* When charging M12 & M18 packs simultaneously

# SET-UP INSTRUCTIONS

**NOTE:** Carefully inspect the pump upon arrival. The carrier, not the manufacturer, is responsible for any damage resulting from shipment.

## 1. Hydraulic Connections

**NOTE:** Ensure areas are clean around fluid ports, and inspect all threads and fittings for signs of wear or damage before use, and replace as needed.

- A. Remove plugs and/or thread protectors/dust covers from hydraulic ports if applicable.
- B. Use an approved, high-grade pipe thread sealant to seal all hydraulic connections and connect fittings and/or hose assemblies to the pump.
- C. Tighten securely and leak-free but do not overtighten.

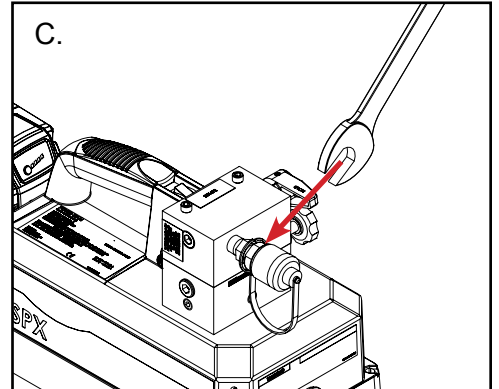
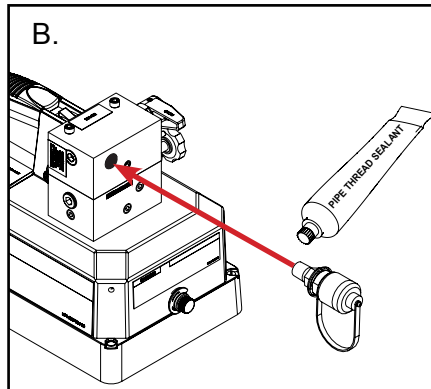
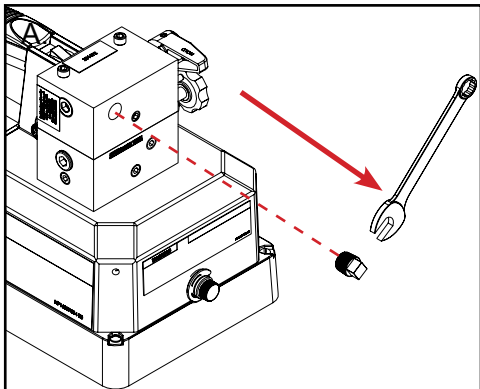

## 2. Checking Hydraulic Fluid and Filling the Bladder.

**NOTE:** Most pumps with a bladder are shipped with hydraulic fluid in the bladder. If hydraulic fluid is needed, use only approved Power Team hydraulic fluid.

- A. Remove the filler cap. (If there is no oil visible, continue to step B)
- B. Insert a clean funnel with filter or strainer.
- C. Fill the bladder completely with hydraulic fluid.
- D. Replace filler cap.

**IMPORTANT:** Tighten filler cap **ONLY 1/2 - 1 turn (MAX)** after O-ring contacts sealing surfaces. Overtightening can cause pump damage on bladder equipped pumps.

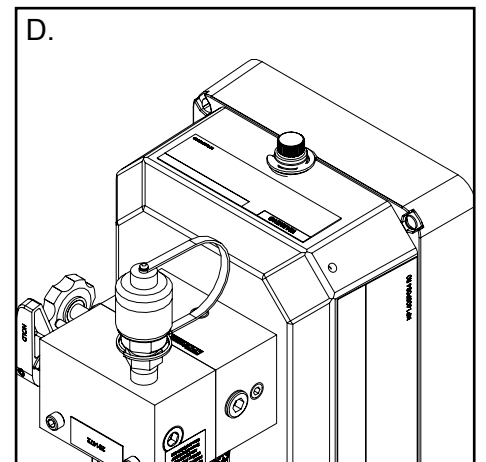
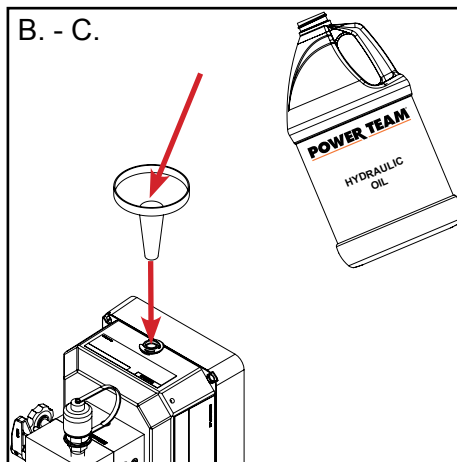
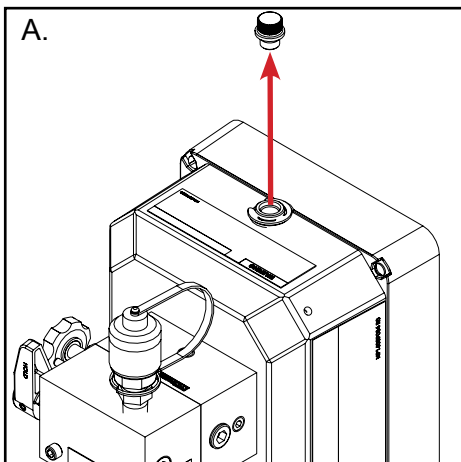

## Setup Instructions continued

### 3. Hydraulic Lines and Fittings.

- Hydraulic lines and fittings can restrict flow to a cylinder or hydraulically actuated device. The restricting or slowing of the fluid flow causes back pressure that slows the device's return. Return speed also varies because of the application, condition of the cylinder or device, inside diameter of hose or fitting, length of the hose, and the temperature and viscosity of the hydraulic fluid.
- Tubes and Hoses should be routed in such a way that they can easily be serviced or removed as well as provide the least resistance to fluid flow. See below for recommended routing configurations.

#### HOSES

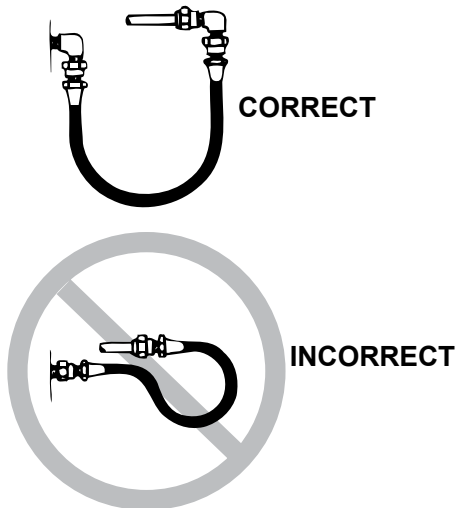

#### TUBING

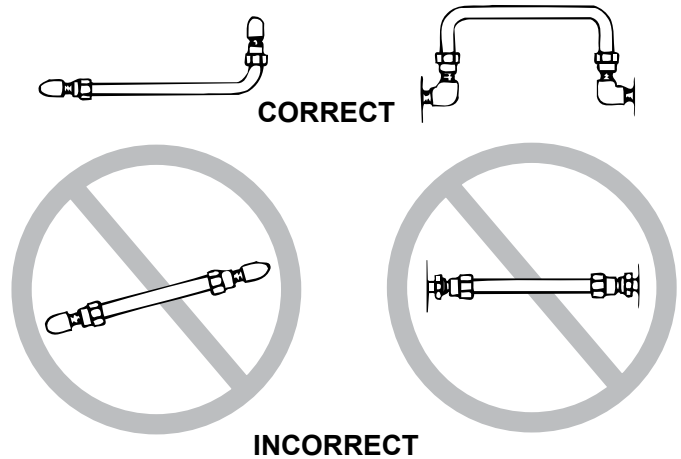

### 4. 18VDC Battery & Charger

**NOTE: New batteries must be charged before first use. Approx. 60 minutes of charging = 100% battery fuel.**

- Ensure battery charger is plugged in.
- Slide battery pack into charger as shown and allow battery to charge.
- Once battery is adequately charged it can be installed on pump unit as shown.
- To remove the battery from the pump unit press the release buttons on the sides of the battery.
- Slide the battery out of the pump unit as shown.

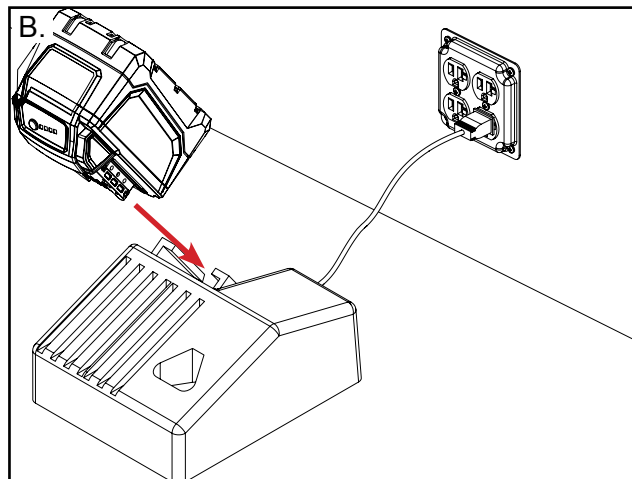
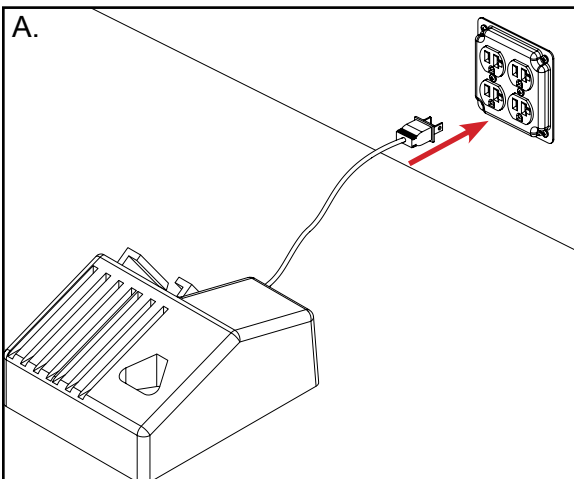

Setup Instructions continued

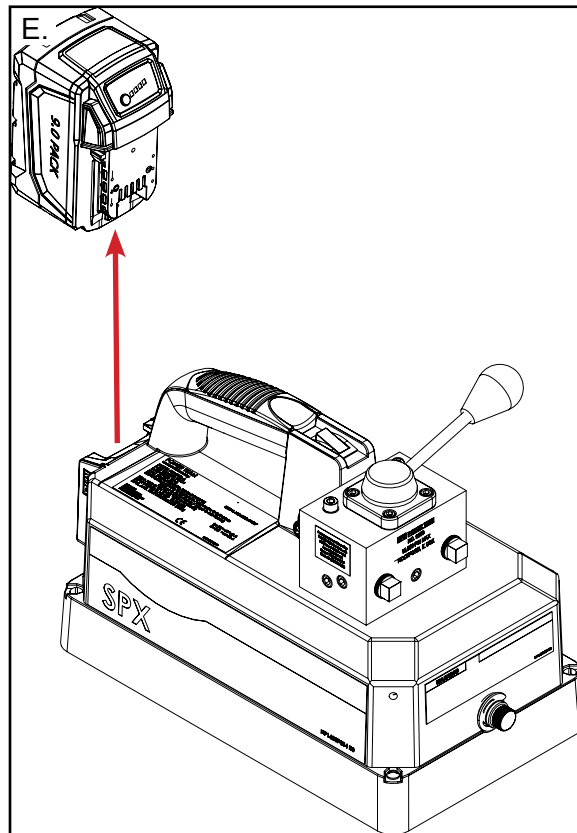
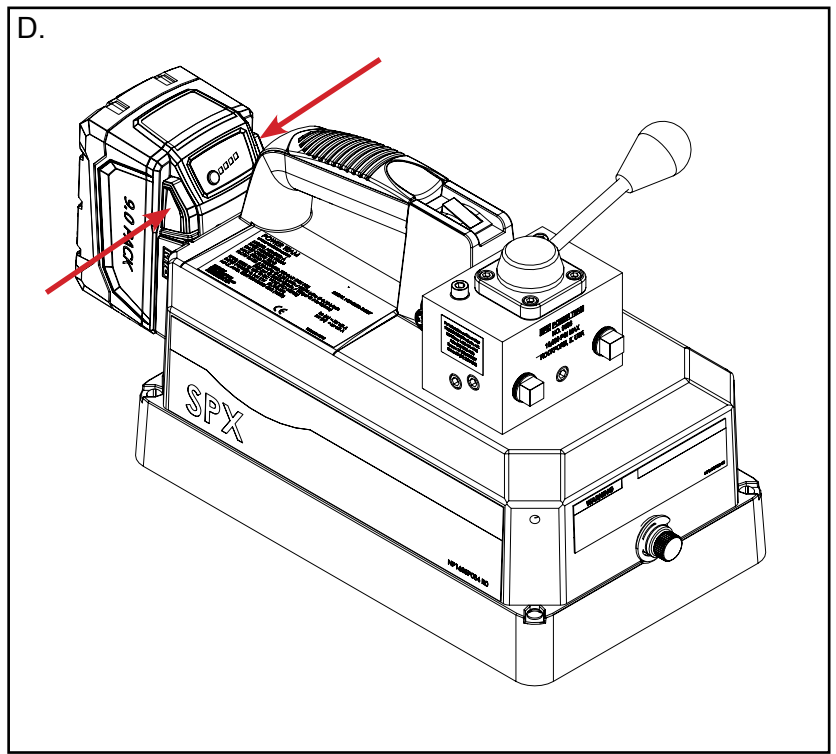
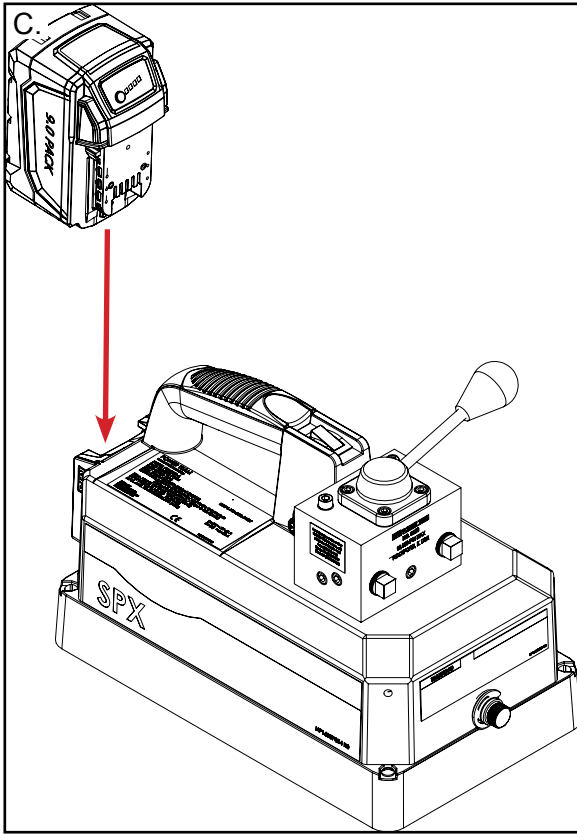

### 5. Bleeding The System

- After all connections are made, the hydraulic system must be bled of any trapped air. Refer to the diagrams below.
- With no load on the system and the pump vented and positioned higher than the accessory tooling, cycle the system several times.
- To vent the Bladder, be sure the pump is positioned upright as shown below and slowly unscrew the bladder plug. Check the bladder for possible low fluid level and fill to proper level with approved, Power Team hydraulic fluid as necessary. Refer to “Checking Hydraulic Fluid and Filling The Bladder” section under Set-up Instructions.

**IMPORTANT:** Some spring return cylinders or rams have a cavity in the rod which forms an air pocket. This type of cylinder or ram should be bled when positioned upside down or lying on its side with the port facing upward.

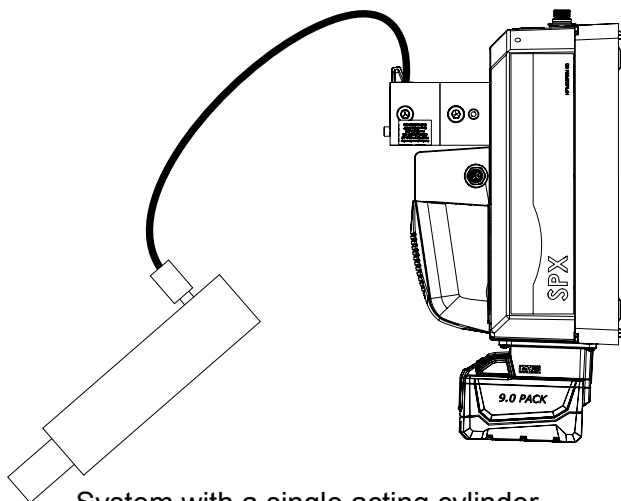

System with a single acting cylinder

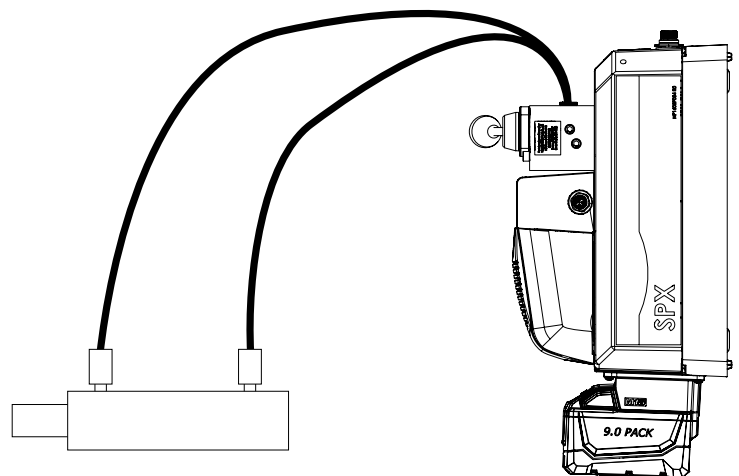

System with a double-acting cylinder

# PUMP OPERATION

## 1. Operating The Pump For The First Time

- A. Valve and hose connections must be tight, and the bladder must be filled to the proper fluid level.
  - Refer to “Hydraulic Connections” and “Checking Hydraulic Fluid and Filling the Bladder” under Set-up Instructions.
- B. Set valve to the neutral or return position and jog the pump on and off several times by pressing the start button and allowing the pump to idle for 1 to 3 minutes.
- C. Set valve to proper position / port to Advance and retract the accessory tooling (e.g. cylinder, torque wrench, spreader, etc.) to its full travel. Do this several times to eliminate air from the system and build pressure.
  - For more complete instructions, refer to the section titled “Bleeding The System” under Set-up Instructions.
- D. With the accessory tooling retracted completely, check the fluid level in the bladder and add fluid if necessary.
  - Refer to “Checking Hydraulic Fluid and Filling The Bladder” under Set-up Instructions.
- E. The pump is now ready to be put into regular operation.

## 2. Attaching And Operating Hand Pendant.

**NOTE: Attaching a hand pendant can sometimes be a more effective way of controlling the pump unit by allowing the user to operate the unit with a remote switch.**

- The hand pendant has an 11 ft. cable and overrides the built in start button.
- A. Notice the Alignment Pin in the cable fitting on the end of the pendant cable.
  - B. Notice the Alignment Groove in the fitting on the pump unit and insert the pendant cable as shown.
  - C. Secure the connection by threading (rotating clockwise) the cable fitting into the pump unit fitting.
  - D. To activate the pump unit press and hold the start button, release the start button and the pump unit will stop running.

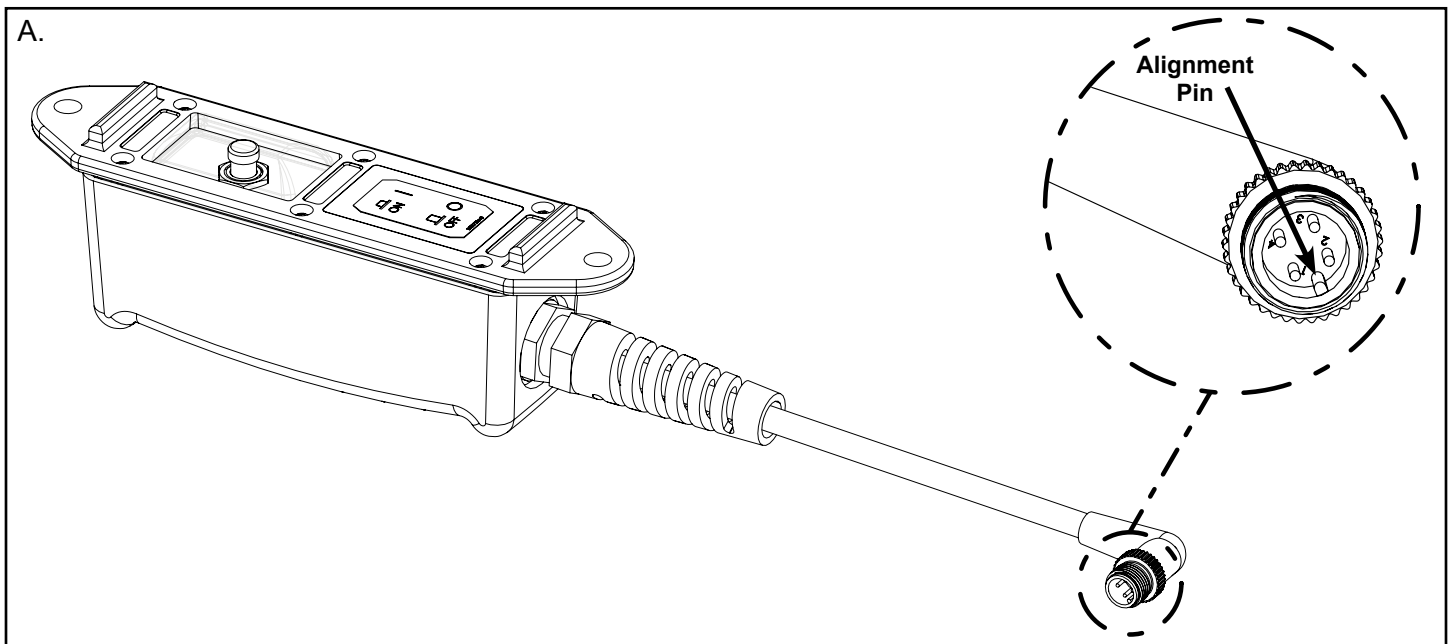

# Pump Operation continued

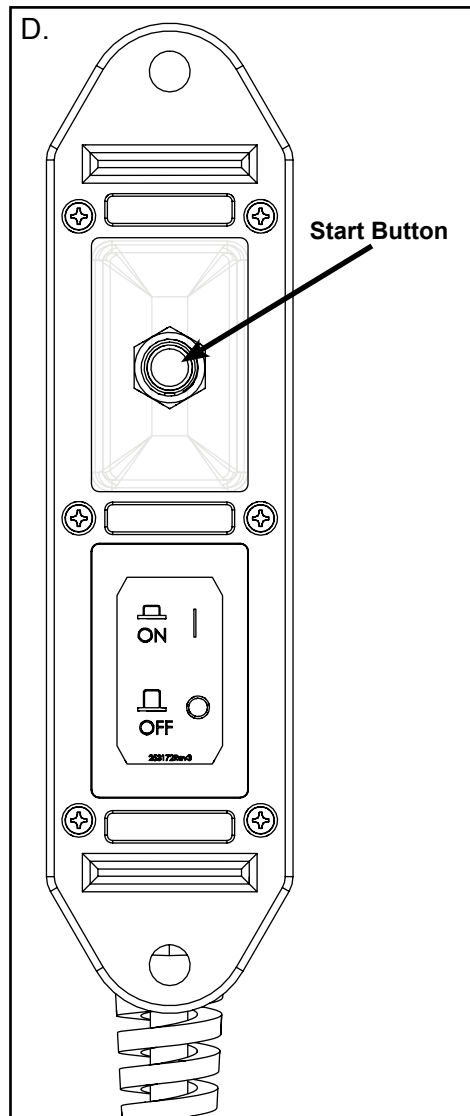
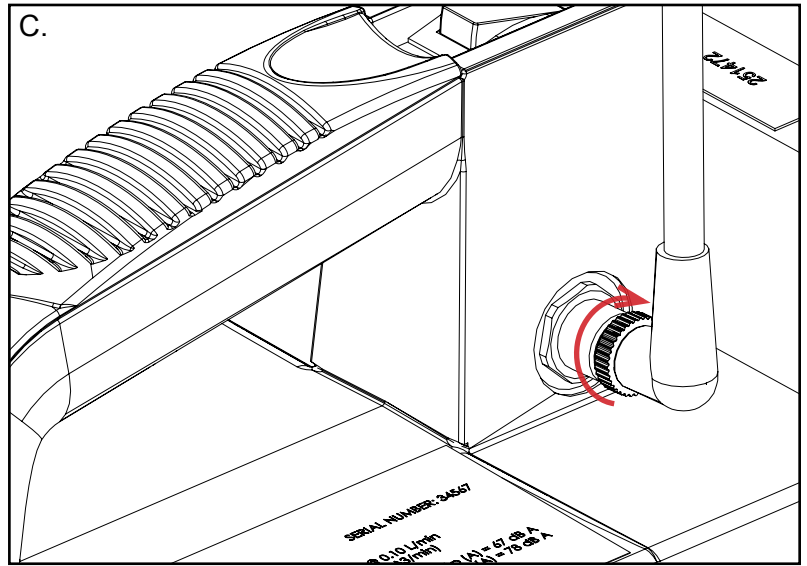
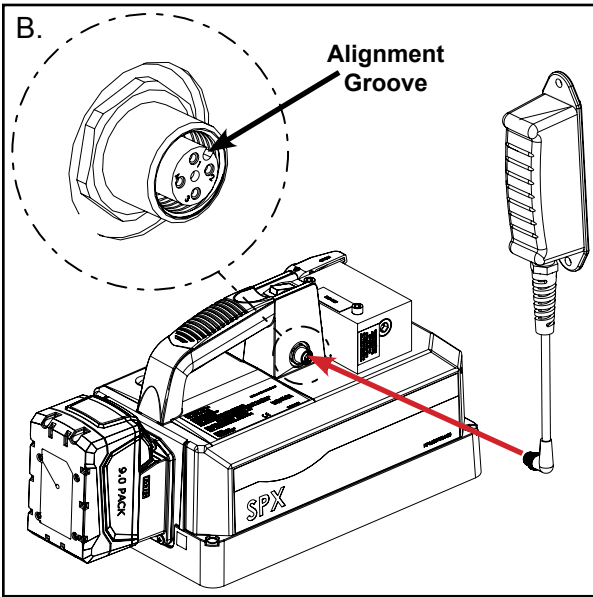

## Pump Operation continued

### 3. Lifting or lowering a load with a hydraulic cylinder.

- A. The load must be under operator control at all times and other personnel must be clear of the load.
- B. The use of blocking and cribbing is recommended to help prevent a falling load.
- C. The use of a load lowering or metering valve is recommended in addition to the correct directional control valve to help prevent a falling load.

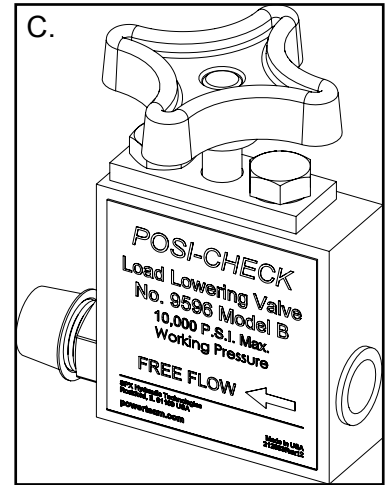
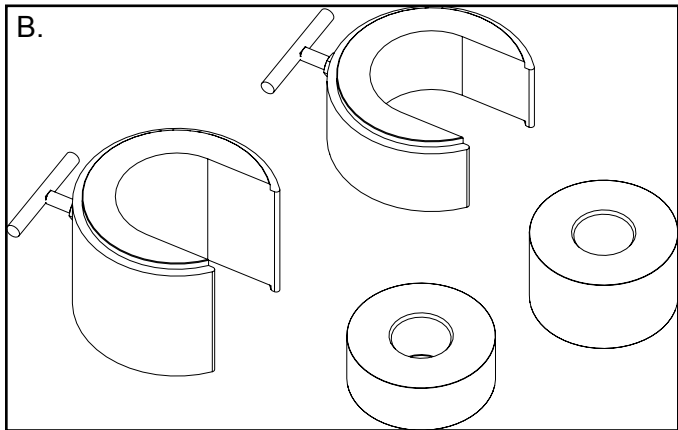



# DIRECTIONAL CONTROL VALVE OPTIONS

## 1. 2-Way Manifold Used With Single-acting Cylinders or Remote Mounted Valves (Figure 1)

- A. Activate the pump unit by pressing the start button to advance the cylinder/accessory tooling.
- B. When the cylinder or tool has advanced to the desired position the pump start button can be released and the cylinder/tool will retract.

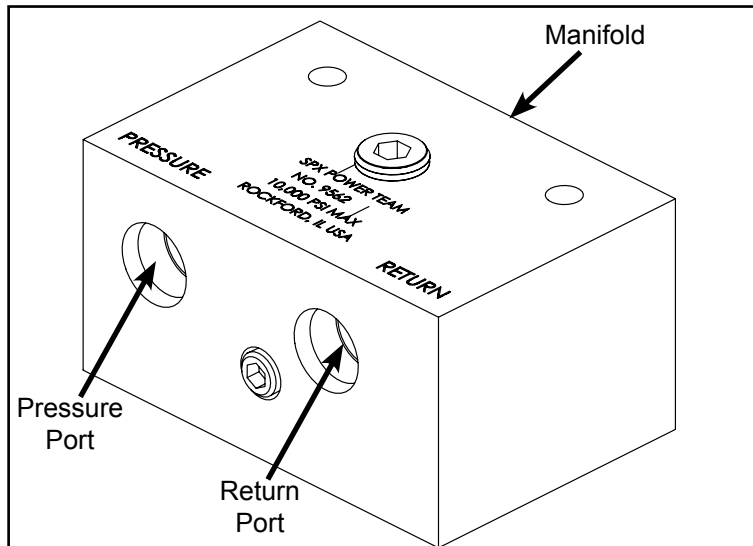
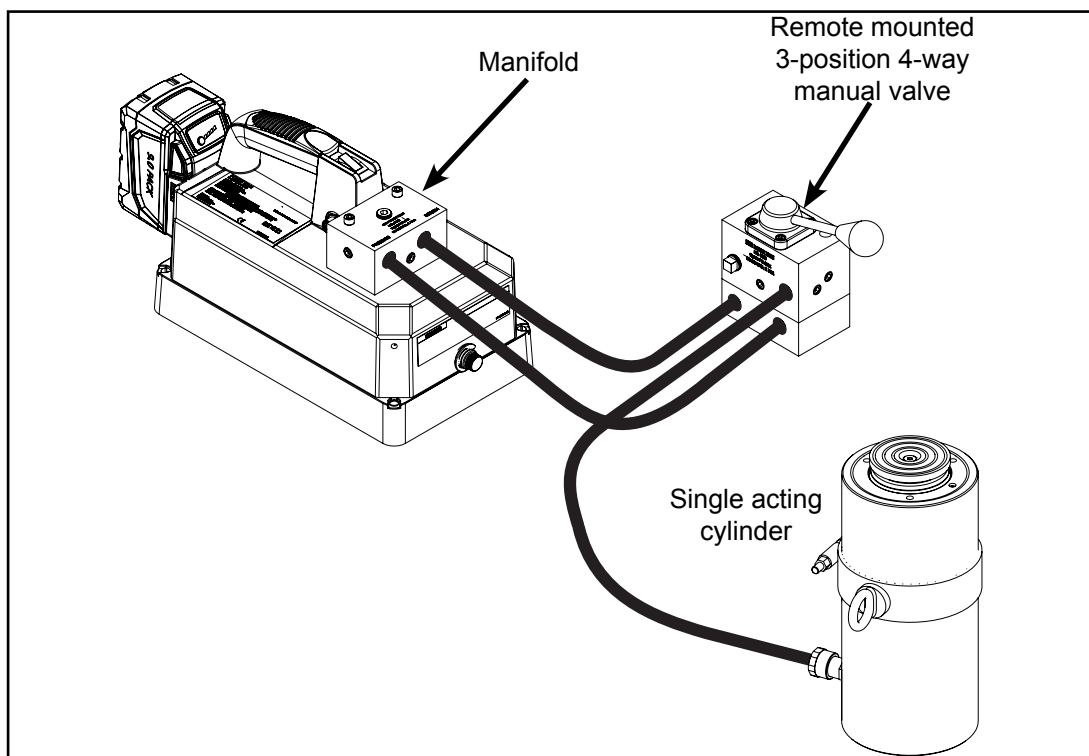

Figure 1

### Example of remote mounted valve:



To prevent sudden, uncontrolled descent of a load as it is being lowered, use Load Lowering Valve (No. 9596) or Counter Balance Valve (No. 9720) in conjunction with the 4-way manual valve in your application

## 2. 2-Position, 2-Way Manual Valve Used With Single-acting Cylinder (Figures 2 & 3)

**NOTE:** Some valves return fluid to the reservoir or bladder when the pump is not running or when the valve control lever is shifted. The correct valve must be used per application, especially when lifting a load.

**⚠ WARNING** Valve (No. 9561) works the same as a manifold if the pump is operated with the valve in the RETURN position. In this position, the cylinder will advance when the pump is running and retract when the pump is not running.

**⚠ DANGER** Never use valve (No. 9561) in the RETURN position when lifting a load!

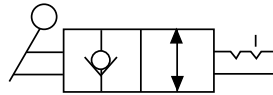

9561

- To HOLD pressure, turn the valve control handle counterclockwise (CCW), (See Figure 2)
- Activate the pump unit to advance the cylinder/accessory tooling.
- When the cylinder or tool has advanced to the desired position the pump start button can be released and the cylinder will HOLD pressure.
- To retract the cylinder, turn the valve control handle clockwise (CW) slowly, (See Figure 3)

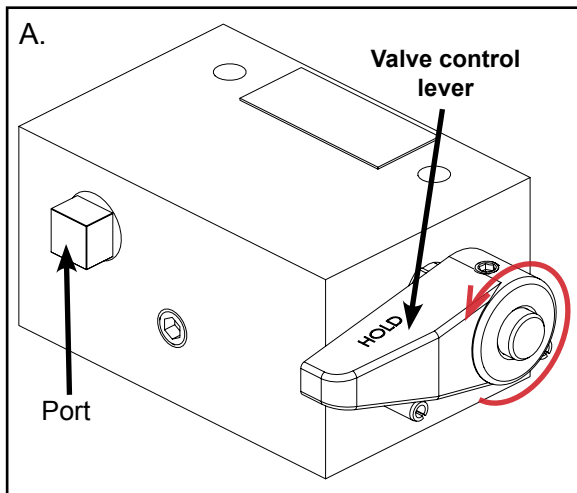

Figure 2

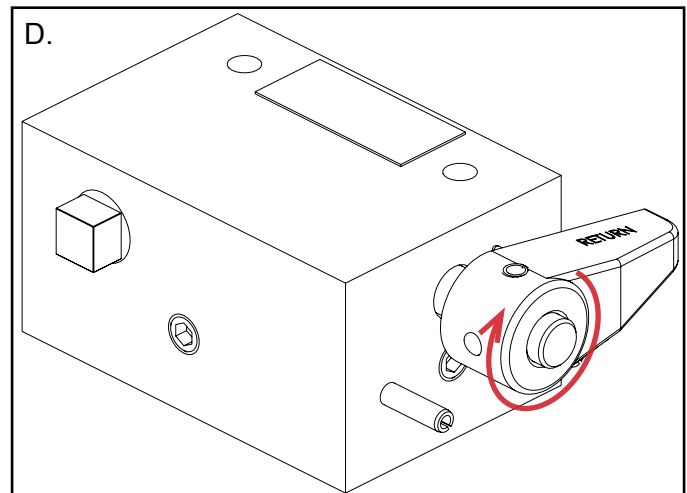
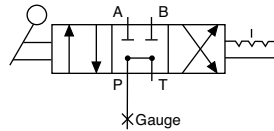

Figure 3

3. 3-Position, 4-Way Manual Valve used with Double-acting Cylinders (Figure 4)



9563  
(non posi-check)

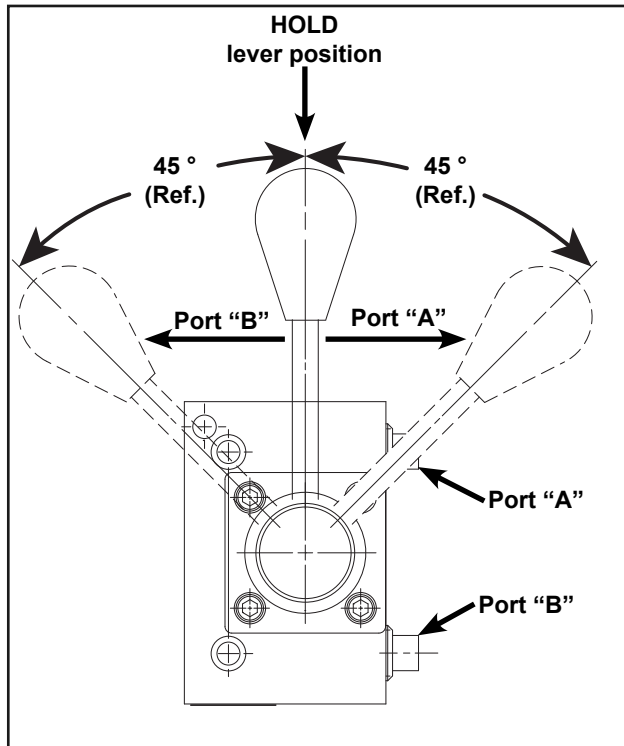

Figure 4

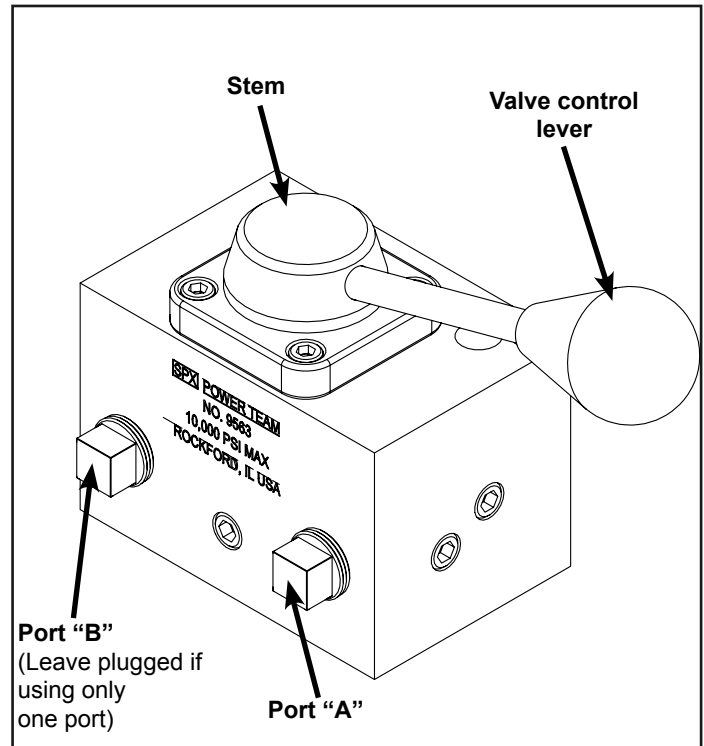

Figure 5

**NOTE:** This valve is a low torque design for use with double-acting or single-acting cylinder(s).

- If this valve is to be used as a 3-way with single-acting cylinder(s), one port must remain plugged (use steel plug). (Figure 5)

- Position the valve control lever in the HOLD position.
- Activate the pump unit.
- Advance the cylinder by shifting the valve control lever to the ADVANCE (Port A) position.
- When the cylinder has advanced to the desired position, turn the pump unit OFF, or shift the valve to the HOLD position.

**NOTE:** Non “posi-check” valves will momentarily lose pressure when shifting to HOLD position.

- Retract the cylinder by shifting the valve control lever to the RETRACT (Port B) position.
- Activate the pump unit if using double-acting cylinders.

## Directional Control Valve Options continued

Examples of typical work holding applications:

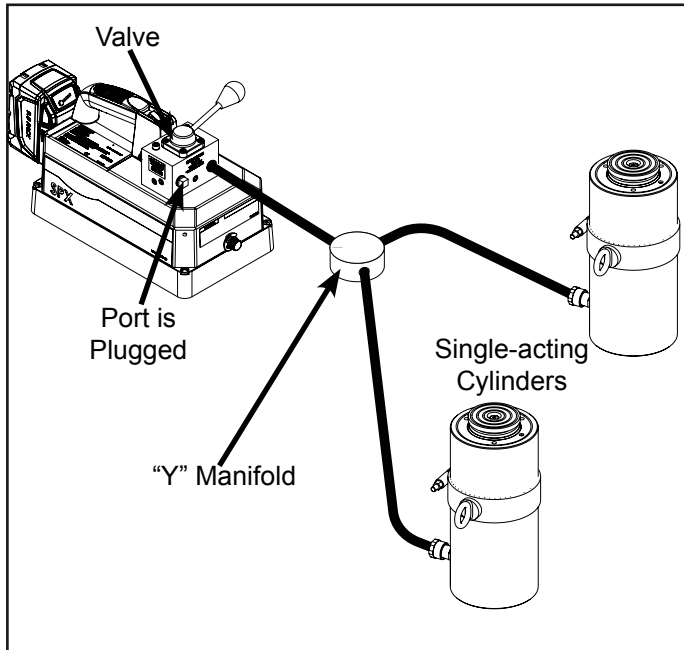

**SINGLE-ACTING CYLINDER(S) IN THE CIRCUIT  
CONTROLLED BY A PUMP-MOUNTED VALVE**

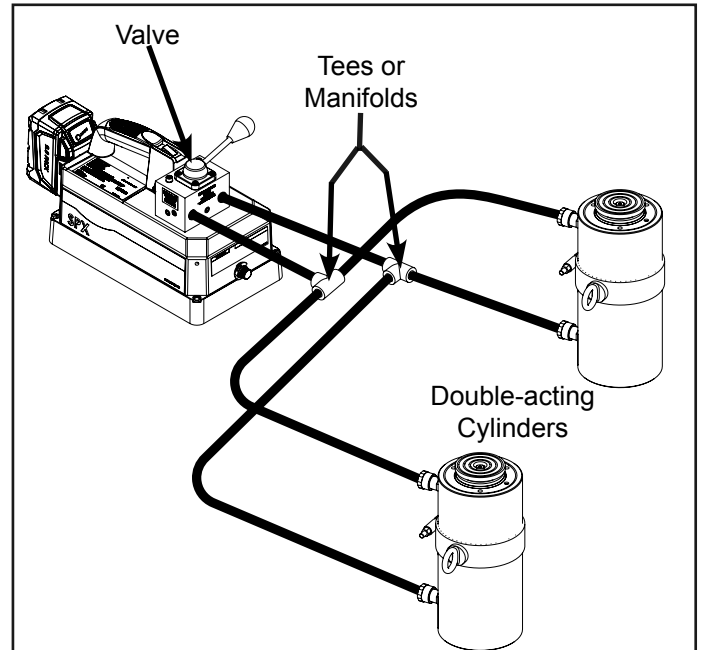

**DOUBLE-ACTING CYLINDER(S) IN THE CIRCUIT  
CONTROLLED BY A PUMP-MOUNTED VALVE**

Other valves are available.  
Consult your dealer, catalog or valve  
operating instructions for details of operation.

# ADJUSTING THE PRESSURE REGULATING CONTROLS

The pressure regulating valve is shown in Figure 6. The pressure regulating valve can be adjusted to bypass fluid at a given pressure setting while the pump continues to run.

## 1. Adjusting The Pressure Regulating Valve

**NOTE:** For easy adjustment of the pressure regulating valve, always adjust the pressure by increasing to the desired pressure setting.

- A. Loosen the locknut (B) on the pressure regulating valve, and back the adjusting screw or knob (A) out a few turns by turning it in a counterclockwise (CCW) direction. This will *decrease* the setting to a lower than desired pressure.
- B. The pump must be completely connected electrically and hydraulically. Start the pump.
- C. Slowly turn the adjusting screw or knob (A) in a clockwise (CW) direction. This gradually *increases* the pressure setting. When the desired pressure is reached, lock the adjusting screw (A) in position by tightening the locknut (B). Shut off the pump.

**IMPORTANT:** The pressure range is from 1,000 to 10,000 PSI (70 to 700 BAR) depending on the pump model.

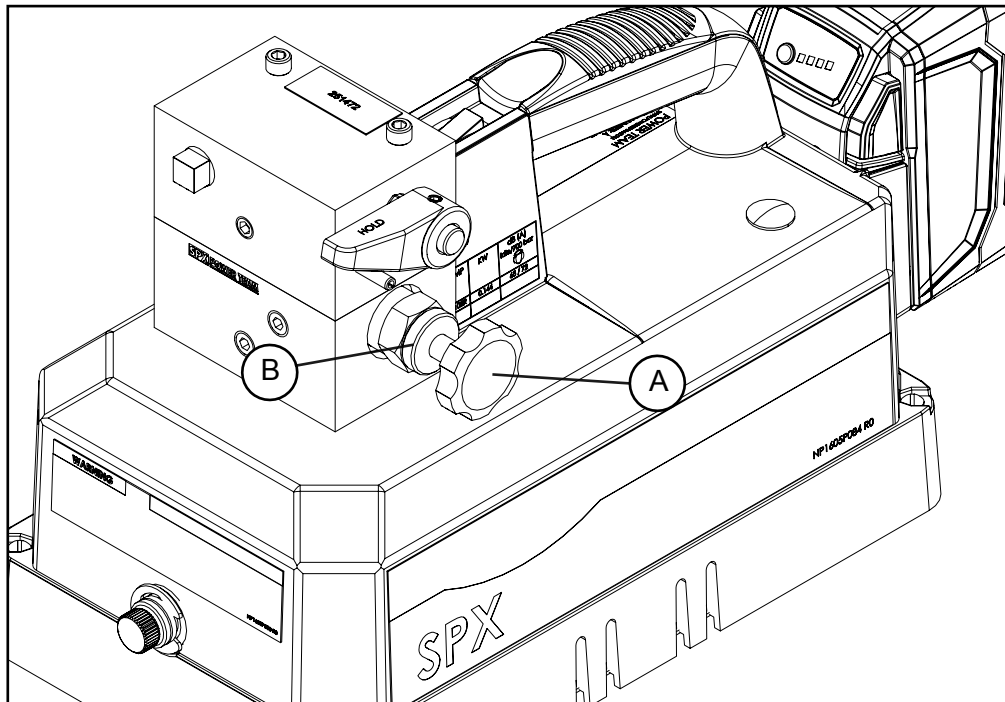

Figure 6

# PREVENTIVE MAINTENANCE

---

**⚠ WARNING** To help prevent personal injury,

- Disconnect the battery from the pump before performing maintenance or repair procedures.
- Repairs and maintenance are to be performed in a dust-free area by a qualified technician.
- The frequency of fluid changes will depend upon the general working conditions, severity of use, and overall cleanliness and care given the pump.
- Three hundred hours of use under general shop conditions is considered a standard change interval. Drain, clean, and refill the reservoir only with approved Power Team hydraulic fluid

## 1. Checking Hydraulic Fluid and Filling the Bladder

**NOTE:** The hydraulic fluid level should be checked after initial set-up and after each ten hours of use.

- A. Thoroughly clean the area around the filler cap with a clean cloth to prevent contamination of the hydraulic fluid.
- B. Cylinder(s)/accessory tooling must be fully retracted and the power supply to the pump disconnected. Position the pump with the filler plug in the upright (or vertical) position.
- C. Remove the filler cap and insert a clean funnel with filter. Fill the bladder completely full with approved Power Team hydraulic fluid.
- D. Replace filler cap.

**IMPORTANT:** Tighten filler cap **ONLY 1/2 - 1 turn (MAX)** after O-ring contacts sealing surfaces. Overtightening can cause pump damage on bladder equipped pumps.

**NOTE:** For more complete instructions, reference “Checking Hydraulic Fluid and Filling the Bladder” under **SETUP INSTRUCTIONS**.

## Preventive Maintenance continued

---

### 2. Maintenance Cleaning

**IMPORTANT:** Never use a high pressure washer to clean hydraulic components!

- A. Keep the pump's outer surface as free from dirt as possible.
- B. Seal all unused couplers with thread protectors.
- C. Keep all hose connections free of dirt and grime.
- D. The breather-hole in the filler cap must be clean and unobstructed at all times.
- E. Equipment connected to the pump must be kept clean.
- F. Use approved Power Team hydraulic fluid in this pump. Change as recommended (every 300 hours). Some conditions may require the use of different viscosity hydraulic fluids.

### 3. Draining And Cleaning The Bladder

**IMPORTANT:** Clean the area around the filler hole to prevent contamination of the hydraulic fluid.

- A. Remove the filler plug and drain hydraulic fluid completely.
- B. Fill bladder half full with clean hydraulic fluid. Flush bladder with clean fluid and drain.

**IMPORTANT:** Never use solvents to clean the bladder! Never disassemble the bladder from the pump!

- C. Fill the bladder completely full with clean approved Power Team hydraulic fluid.

---

## TROUBLESHOOTING GUIDE

---



**WARNING** To help prevent personal injury, any repair work or troubleshooting must be done by qualified personnel familiar with this equipment.

- Use the proper gauges and equipment when troubleshooting.

**NOTE:** For a detailed parts list or to locate a Power Team Authorized Hydraulic Service Center contact your nearest Power Team facility.



**WARNING** It is best to check for system leaks by using a hand pump and applying pressure to the suspect area. Watch for leaking fluid and follow it back to its source. Never use your hand or other body parts to check for a possible leak.

## Troubleshooting Guide continued

PROBLEM	CAUSE	SOLUTION
<p><b>Electric motor does not run.</b></p> <p><b>⚠ WARNING</b></p> <p><b>To help prevent personal injury, disconnect power supply before removing cover. Any electrical work should be performed by a qualified electrician.</b></p>	<ol style="list-style-type: none"> <li>1. No voltage supply.</li> <li>2. Broken lead wire or defective internal wiring.</li> <li>3. Overheated motor has caused over current protection to disengage.</li> <li>4. Battery does not have sufficient charge</li> </ol>	<ol style="list-style-type: none"> <li>1. Check battery voltage. (Ensure battery is charged)</li> <li>2. Contact a Power Team Authorized Hydraulic Service Center.</li> <li>3. Wait for motor to cool before restarting.</li> <li>4. Charge or replace battery.</li> </ol>
<p><b>Electric motor will not shut off.</b></p>	<ol style="list-style-type: none"> <li>1. Defective motor controls.</li> </ol>	<ol style="list-style-type: none"> <li>1. Disconnect from power supply and contact a Power Team Authorized Hydraulic Service Center.</li> </ol>
<p><b>Electric motor stalls, surges, overheats or will not start under a load.</b></p>	<ol style="list-style-type: none"> <li>1. Low voltage.</li> </ol>	<ol style="list-style-type: none"> <li>1. Refer to the “Electric Pump” information under “Pump Operation” section.</li> </ol>
<p><b>Electric overload protector keeps tripping.</b></p>	<ol style="list-style-type: none"> <li>1. Excessive load.</li> <li>2. Damaged wires or components.</li> </ol>	<ol style="list-style-type: none"> <li>1. Allow to cool then restart.</li> <li>2. Return to service center.</li> </ol>
<p><b>Pump is not delivering fluid or delivers only enough fluid to advance cylinder(s) partially or erratically.</b></p>	<ol style="list-style-type: none"> <li>1. Fluid level too low.</li> <li>2. Quick disconnect couplings are not completely coupled.</li> <li>3. Air in system.</li> <li>4. Cold fluid or fluid too viscous.</li> <li>5. Bladder capacity is too small for the size of cylinder(s) used.</li> </ol>	<ol style="list-style-type: none"> <li>1. Fill reservoir or bladder according to directions “Filling The Pump Bladder” under “Set-up Instructions” section.</li> <li>2. Check quick-disconnect couplings to cylinders to ensure that they are completely coupled. Occasionally couplers have to be replaced because the ball check does not stay open due to wear.</li> <li>3. Refer to the section titled “Bleeding the System” under “Set-up Instructions” section.</li> <li>4. Hydraulic fluid is of a higher viscosity than necessary. Change to a lighter fluid.</li> <li>5. Use smaller cylinder(s).</li> </ol>



## Troubleshooting Guide continued

PROBLEM	CAUSE	SOLUTION
<b>Pump builds pressure but cannot maintain pressure.</b>	1. External leaks.	1. Seal leaking pipe fittings with pipe sealant. Replace leaking pipes or hoses.
	2. Internal or external leakage on hydraulic cylinder.	2. Remove the cylinder from pump. If the pump builds and maintains full pressure, the cylinder is defective. Contact a Power Team Authorized Hydraulic Service Center.
	3. Leaking control valve or check valve	3. Contact a Power Team Authorized Hydraulic Service Center.
<b>Pump will not build full pressure.</b>	1. Faulty pressure gauge.	1. Calibrate gauge.
	2. Check for external leakage.	2. Seal faulty fittings with sealant. Replace leaking pipes or hoses.
	3. Improperly adjusted external pressure regulator setting.	3. Refer to “Adjusting The Pressure Regulator Valve” information under “Adjusting the pressure Regulating Controls” section.
	4. Internal or external leakage on hydraulic cylinder.	4. Remove the cylinder from the pump. If the pump builds full pressure, the cylinder is defective. Contact a Power Team Authorized Hydraulic Service Center.
	5. Inadequate power supply.	5. Refer to “Pump Operation” section.
	6. Leaking control valve or defective pump.	6. Contact a Power Team Authorized Hydraulic Service Center.

## Troubleshooting Guide continued

PROBLEM	CAUSE	SOLUTION
Cylinder(s) will not retract or extend.	1. Quick disconnect couplings are not completely coupled.	1. Check quick disconnect coupling to cylinders to ensure that they are completely coupled. Occasionally couplers have to be replaced because the ball check does not stay open due to wear.
	<p><b>⚠ DANGER</b></p> <p><b>A Double acting cylinder or ram must have <i>both</i> hoses and all couplers securely connected to both ports. If one of the two ports is restricted or becomes disconnected, pressure will build and the cylinder, hose or coupler can burst, possibly causing serious injury or death.</b></p>	
Pump delivers excess oil pressure.	2. Broken return spring in spring return cylinder or seals blown in double-acting cylinder.	2. Contact a Power Team Authorized Hydraulic Service Center.
	1. Faulty pressure gauge.	1. Calibrate gauge.
	2. Relief valve not properly set.	2. Contact a Power Team Authorized Hydraulic Service Center.

# PARTS LIST

## PB10 Series Hydraulic Pump

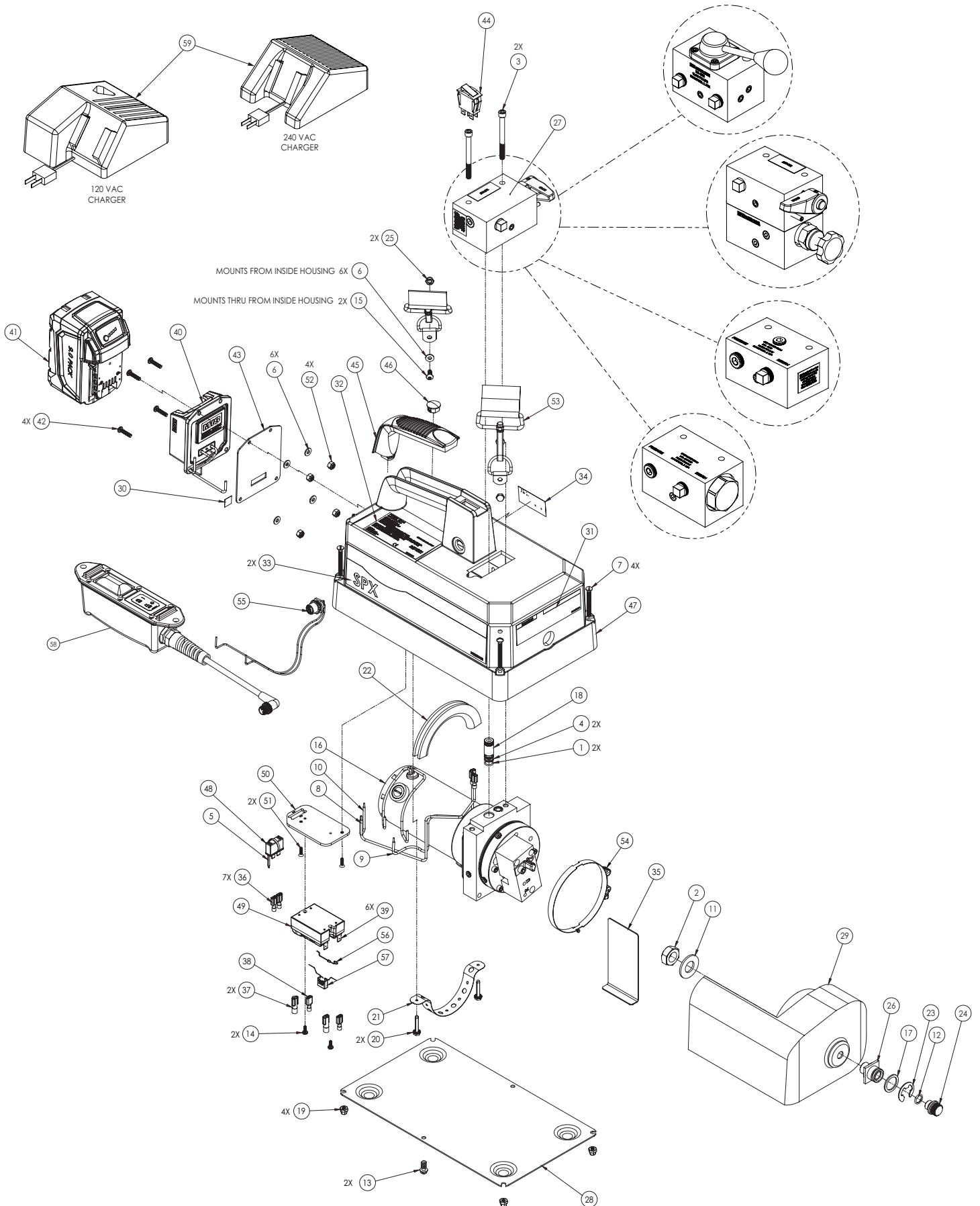

**Parts List continued**

ITEM	PART NO.	DESCRIPTION	QTY.
1	10268	O-RING (-012) 0.316 ID x 0.070 NITRILE 70 (INCLUDED WITH VALVE 420558 AND 350623)	2
2	10394	NUT, JAM, 5/8-18 UNF	1
3	10855	SCREW, SCKT HD CAP - 1/4-20 x 2.75	2
	251077	SCREW, SHC 1/4-20 X 4.75 (USED ON PB102R)	2
	251078	SCREW, SHC 1/4-20 X 3.25 (USED ON PB102-CP)	2
4	11863	WASHER, BACKUP 0.50 x 0.375 (INCLUDED WITH VALVE 420558 AND 350623)	2
5	12313	CABLE TIE, NON-RELEASABLE	1
6	12355	WASHER, PLAIN 0.44 X 0.19 X 0.05 STEEL	6
7	12515	SCREW, RND 10-24 X 1.75	4
8	12747	WIRE, 14GA XXIN RED	1
9	12747	WIRE, 14GA XXIN RED	1
10	12747	WIRE, 14GA XXIN RED	1
11	13324	WASHER, PLAIN 1.330 x0.660	1
12	13755	O-RING (-905) 0.414ID X 0.072 NITRILE 90	1
13	14456	SCREW, HEX WSH #10-24 X 0.50 TAPPING	2
14	15468	SCREW, #6-32UNC 0.375 IN PNH-ST ZN	2
15	16811	SCREW, #10-32 X 0.50 BHCS	2
16	65187-18	PUMP SUBASSY, ELECTRIC 18VDC	1
17	201373	WASHER, RETAINER 1.000 x0.750	1
18	202505	BUSHING (INCLUDED WITH VALVE 420558 AND 350623)	1
19	207405	LOCKNUT, HEX: #10-24 FLEXIBLE LOCKING	4
20	211060	SCREW, HEX. WASHER HD.TAPPING - #9-15 x 1 PLASTITE	2
21	251039	STRAP, MOTOR MOUNTING	1
22	251041	CHANNEL, RUBBER	1
23	251043	RING, RETAIN EXT 0.62 X .050	1
24	251280	PLUG, O RING BOSS: 1/2-20 UNF	1
25	252871	NUT, HEX ACORN CAP #10-32	2
26	350583	ADAPTER, FILLER	1
27	350622	VALVE, MANUAL, 2 POSITION, 2 -WAY (USED ON PB102, PB102P, PB102R)	1
	420558	VALVE, MANUAL (3-POSITION, 4-WAY) (USED ON PB104)	1
	350623	BODY, VALVE (PRESSURE REGULATOR) (USED ON PB102R)	1
	350720	MANIFOLD ASSEMBLY (USED ON PB102A)	1
	3001123	MANIFOLD ASSEMBLY (USED ON PB102-CP)	1
28	420607	PLATE, BASE	1
29	420643	BLADDER	1
30	1000413	LABEL, WEEE (WHEELIE BIN)	1
31	1001026	DECAL, PLAS SAFE INST US RECT 4.90IN	1

**Parts List continued**

ITEM	PART NO.	DESCRIPTION	QTY.
32	1001029	DECAL, PLAS CERT CE US RECT 4.25IN (USED ON PB102P)	1
	1001030	DECAL, PLAS CERT CE US RECT 4.25IN (USED ON PB102R)	1
	1001031	DECAL, PLAS CERT CE US RECT 4.25IN (USED ON PB102A)	1
	1001054	DECAL, PLAS CERT CE US RECT 4.25IN (USED ON PB102)	1
	1001055	DECAL, PLAS CERT CE US RECT 4.25IN (USED ON PB104)	1
	1001143	DECAL, PLAS CERT CE US RECT 4.25IN (USED ON PB102-CP)	1
33	1001053	DECAL, PLAS LOGO PTEM US RECT 10.7IN	2
34	1001058	DECAL, PLAS CERT CE US RECT 1.73IN (USED ON PB102P)	1
	1001036	DECAL, PLAS CERT CE US RECT 1.73IN (USED ON PB102R)	1
	1001037	DECAL, PLAS CERT CE US RECT 1.73IN (USED ON PB102A)	1
	1001057	DECAL, PLAS CERT CE US RECT 1.73IN (USED ON PB102)	1
	1001038	DECAL, PLAS CERT CE US RECT 1.73IN (USED ON PB104)	1
	1001144	DECAL, PLAS CERT CE US RECT 1.73IN (USED ON PB102-CP)	1
35	2001397	SPACER, BLADDER	1
36	2001467	TERMINAL,QUICK DISCONNECT FEMALE	7
37	2001486	TERMINAL, QUICK DISCONNECT, FEMALE	2
38	2007914	TERMINAL,QUICK DISCONNECT - FEM 18-22AWG	1
39	2008866	TERMINAL, ADAPTOR, SLOT TO .25 SPADE	6
40	2009627	M18 ODM ADAPTOR - HD V1030	1
41	2009628	BATTERY, 9.0 AMP, LI-ION TYPE	1
42	2009629	SCREW, #8-32UNC 0.75 IN PNH 2 ST BOX	4
43	2009630	GASKET, 3.80INx2.60x0.06xPU 70	1
44	2009631	SWITCH, ROCKER OFF - (ON) MOMENTARY	1
45	2009632	HANDLE - RUBBER, RETAINER PLUG, THIN BODY	1
46	2009633	PLUG, CAP 0.625IN D-FLATS NYLON6-6	1
47	2009634	HOUSING, HYD. PUMP RND MTR, MACH	1
48	2009635	FUSE, AUTO RESET 30AMP DUAL 1/4" FASTON	1
49	2009636	RELAY, SSR OPR 1-60VDC, CTRL4-32VDC, 40A	1
50	2009637	PLATE, RECT ADPTx0.1INx2.0x3.5 AL	1
51	2009638	SCREW, #6-32UNC 0.5 IN CSK 4 ST ZN	2
52	2009640	NUT, 8-32UNFx0.75IN LCK ST ZN	4
53	2009649	ASSY, HARNESS, STRAP, CLIP, MOUNT	1
54	2009650	CLAMP, HOSE 3.70-4.13 SCREW DRIVE	1
55	2009652	CONNECTOR, 4 PIN 18GA FEM NIBR	1
56	2009656	DIODE, SUPPRESSION 600V, 1N4005	1
57	2010059	CAPACITOR, 0.068 MICRO FARAD CLASS X2	1
58	3000989	REMOTE PUMP HAND SWITCH ASSEMBLY (INCLUDED WITH PB102P)	1
59	2009646	CHARGER, LI-ION BATTERY 120VAC (USED WITH PB10XX-1 MODELS)	1
	2009647	CHARGER, LI-ION BATTERY 240VAC (USED WITH PB10XX-2 MODELS)	1

## 65187-18 (Pump Sub-assembly, electric 18VDC)

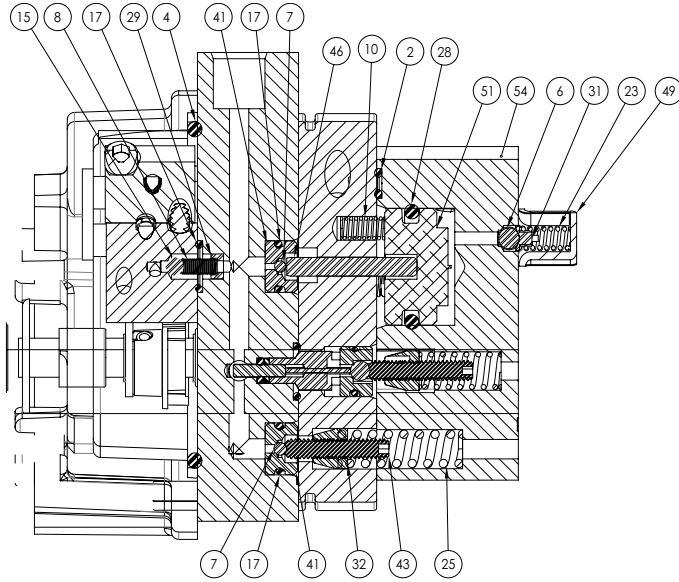

SECTION A-A

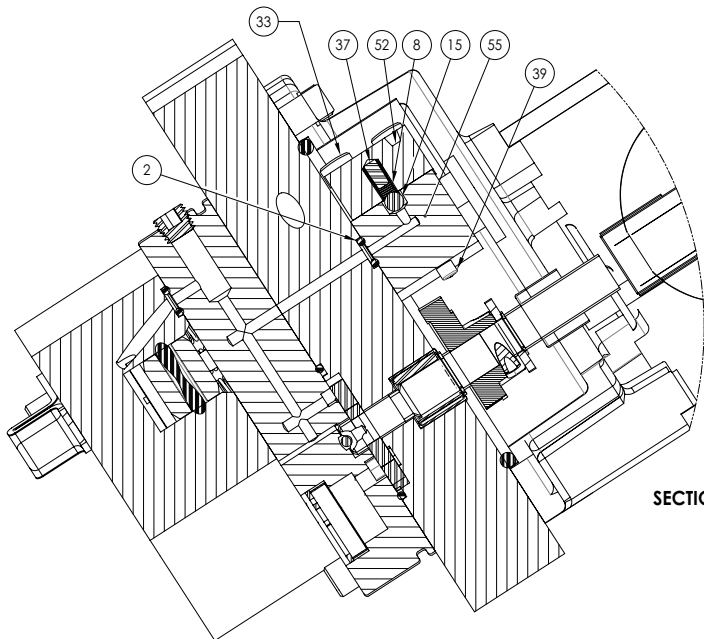
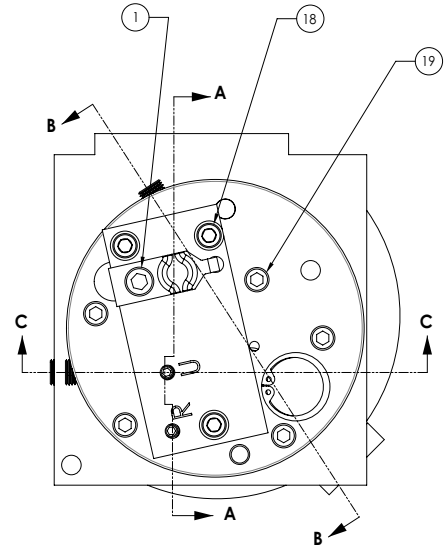

SECTION B-B

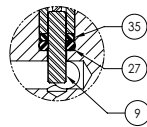

DETAIL F

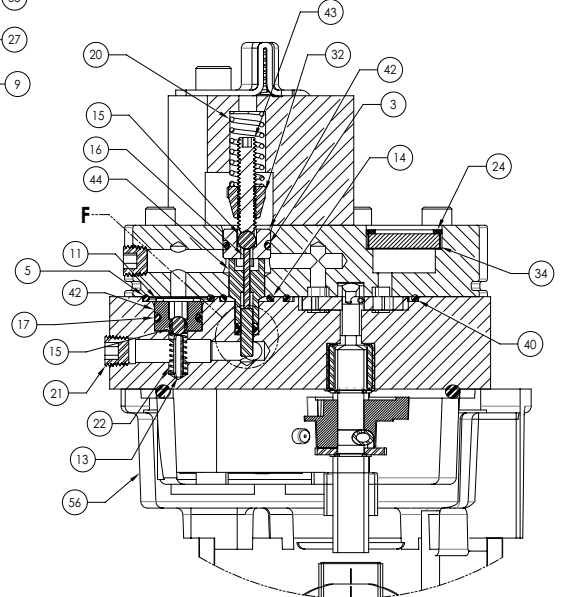

SECTION C-C

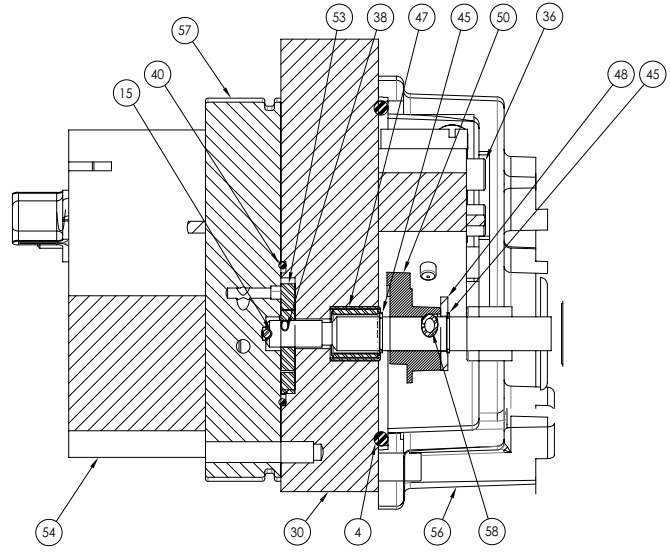
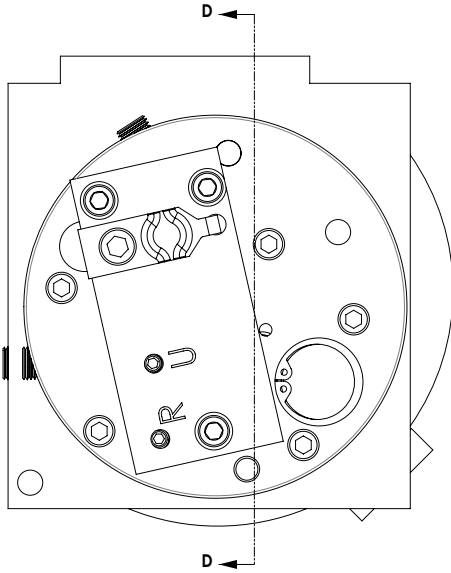

SECTION D-D

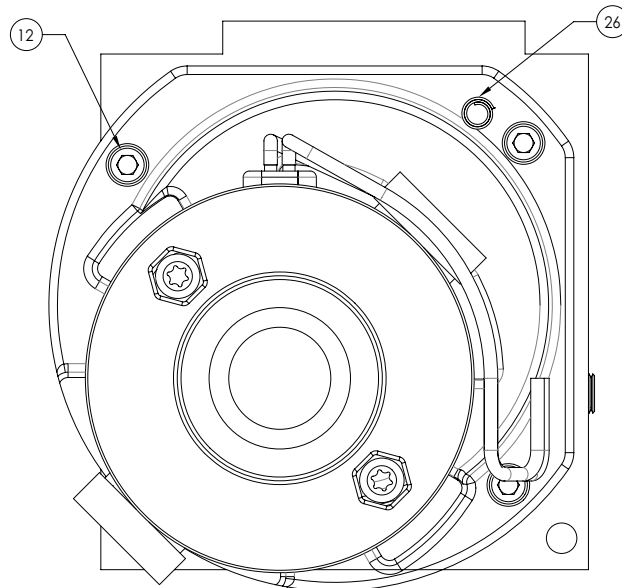

MOTOR END VIEW

**Parts List continued**

ITEM NO.	PART NO.	DESCRIPTION	QTY.
1	10002	SCREW, 1/4-20UNC X 0.375IN SHC G8 ST BOX	1
2	10265	ORING (-008) 0.176 x 0.07 x0.316IN NBR70	2
3	10268	O-RING (-012) 0.316 ID x 0.070 NITRILE 70	1
4	10297	O-RING (-236) 3.234ID X 0.139 NITRILE 70	1
5	10302	O-RING (-016) 0.614ID X 0.070 NITRILE 70	1
6	10374	BALL, 7/32" DIA STEEL	1
7	10418	BALL, 1/8" DIA STEEL	2
8	10445	SPRING COM. OD .166I.D. XXXR .580 751MW	2
9	10796	PIN, DOWEL .13 X .50	1
10	11024	SPRING, COMPRESSION	3
11	11031	WASHER, PLAIN 0.31 x 0.47 x 0.03 COPR	1
12	11434	SCREW, SOCKET HD CAP - #10-24 X 0.50	3
13	11512	PIN, SPRING .094 X .437	1
14	12098	ORING, -113 0.549X0.103X0.755IN NBR70	1
15	12223	BALL, 3/16" DIA STEEL	5
16	13937	PIN, HARDENED GROUND MACHINE DOWEL - STANDARD SERIES	1
17	13943	O-RING (-012) 0.364ID X 0.070 URETHAN 92	4
18	14423	SCREW, SHC 10-24 X 2.00	3
19	14426	CAP SCREW	5
20	14484	SPRING,COMP.,.316x.047x1.00	1
21	15130	FITTING, PLUG 1/16 PTF FLUSH	3
22	15141	SPRING, COMPRESSION - 0.186 O.D. x 0.656 LG	1
23	15691	SPRING COM OD.246IDX.XXXR57L.645MW	1
24	16686	RING, RETAINING - INTERNAL	1
25	16724	COMPRESSION SPRING	1
26	17567	PIN, SPRING COILED .25 X .75	2
27	17797	O-RING	1
28	19029	O-RING (-213) 0.921ID X 0.139 VITON 75	1
29	24549	GUIDE, BALL	1
30	64346	BODY, PUMP	1
31	200796	ADAPTER, BALL & SPRING	1
32	207405	LOCKNUT, HEX: #10-24 FLEXIBLE LOCKING	2
33	211054	SCREW, SOCKET HD. CAP: SELF-LOCKING	3
34	214578	FILTER	1
35	214992	WASHER, BACKUP 0.240 x0.130	1
36	250491	SCREW, SHC 10-24 X 1.250	4
37	251040	PIN, DOWEL .13 X .25	1
38	251061	PIN, DOWEL .06 X .38	1
39	251062	PISTON 5/32 DIA.	1
40	251063	O-RING (-027) 1.301ID X 0.070 NITRILE 70	1
41	251064	SEAT, REPLACEABLE	2



**Parts List continued**

ITEM NO.	PART NO.	DESCRIPTION	QTY.
42	251065	SEAT, REPLACEABLE	2
43	251067	SCREW, HEX SOCKET SET: PLAIN CUP PT #10-24 x 1	2
44	251068	GUIDE - UNLOADING PIN	1
45	251069	Retaining Ring	2
46	251083	PIN, HARDENED GROUND MACH DOWEL - 3/16 x 1-1/4	1
47	251129	BEARING, NEEDLE - .375 x .562 x .500	1
48	252169	WASHER, PLAIN, SPECIAL	1
49	350577	RETAINING, SPRING	1
50	350606	ECCENTRIC	1
51	350619	PISTON, AUTOMATIC VALVE	1
52	350620	BODY, HIGH PRESSURE CAP	1
53	420615	SET, GEROTOR	1
54	420616	BODY, AUTO. VALVE	1
55	420617	BODY, HIGH PRESSURE PISTON	1
56	421297-18-G	MOTOR, E 0.19HP 18V 2T 3.19 7000RPM	1
57	2009663	PLATE, PUMP END	1
58	2009972	PIN, ROLL 0.156x0.555IN ST BOX	1

**350622**  
(Valve, Manual, 2-position, 2-Way)

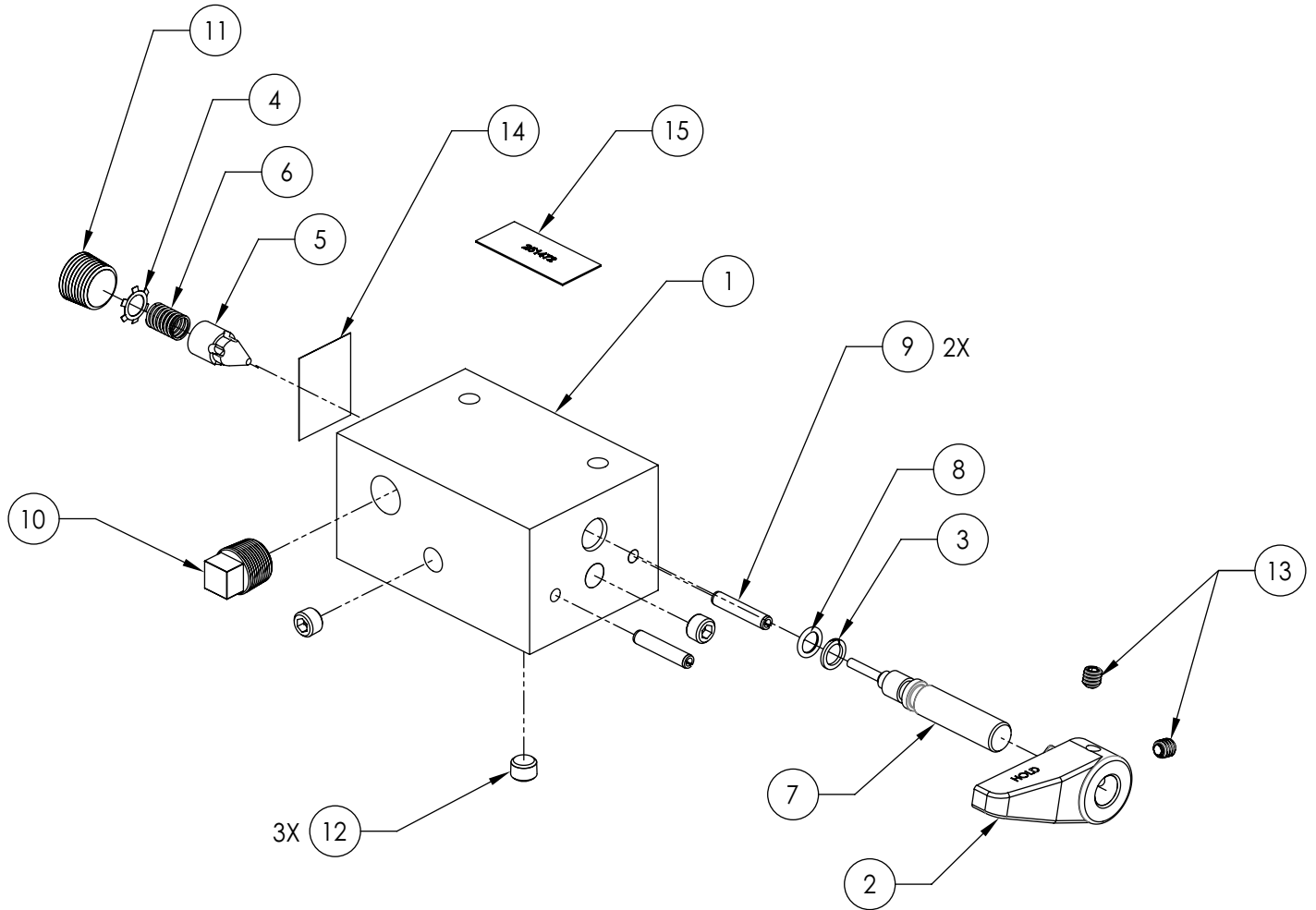

ITEM NO.	PART NO.	DESCRIPTION	QTY.
1	58351	BODY, VALVE, 2 WAY	1
2	213109	HANDLE, RELEASE VALVE	1
3	15085	WASHER, BACK-UP: 0.438 x 0.312	1
4	11088	RING, RETAINING - INTERNAL	1
5	20771	POPPET	1
6	10425	SPRING, COMPRESSION	1
7	350626	SCREW, RELEASE VALVE	1
8	10267	ORING -011 0.301X0.07X0.441IN NBR 70	1
9	11418	PIN, SLOTTED SPRING STANDARD DUTY	2
10	11127	FITTING, PLUG 3/8 NPTF W/SEALANT	1
11	10909	FITTING, PLUG - 3/8 NPTF M FLUSH	1
12	251279	FITTING, PLUG 1/8 PTF	3
13	10556	SCREW, 1/4-20 SET LOCK	2
14	251512	DECAL, TELEPHONE INFORMATION	1
15	251472	DECAL, WARNING	1

**420558**  
(Valve, Manual 3-Position, 4-Way)

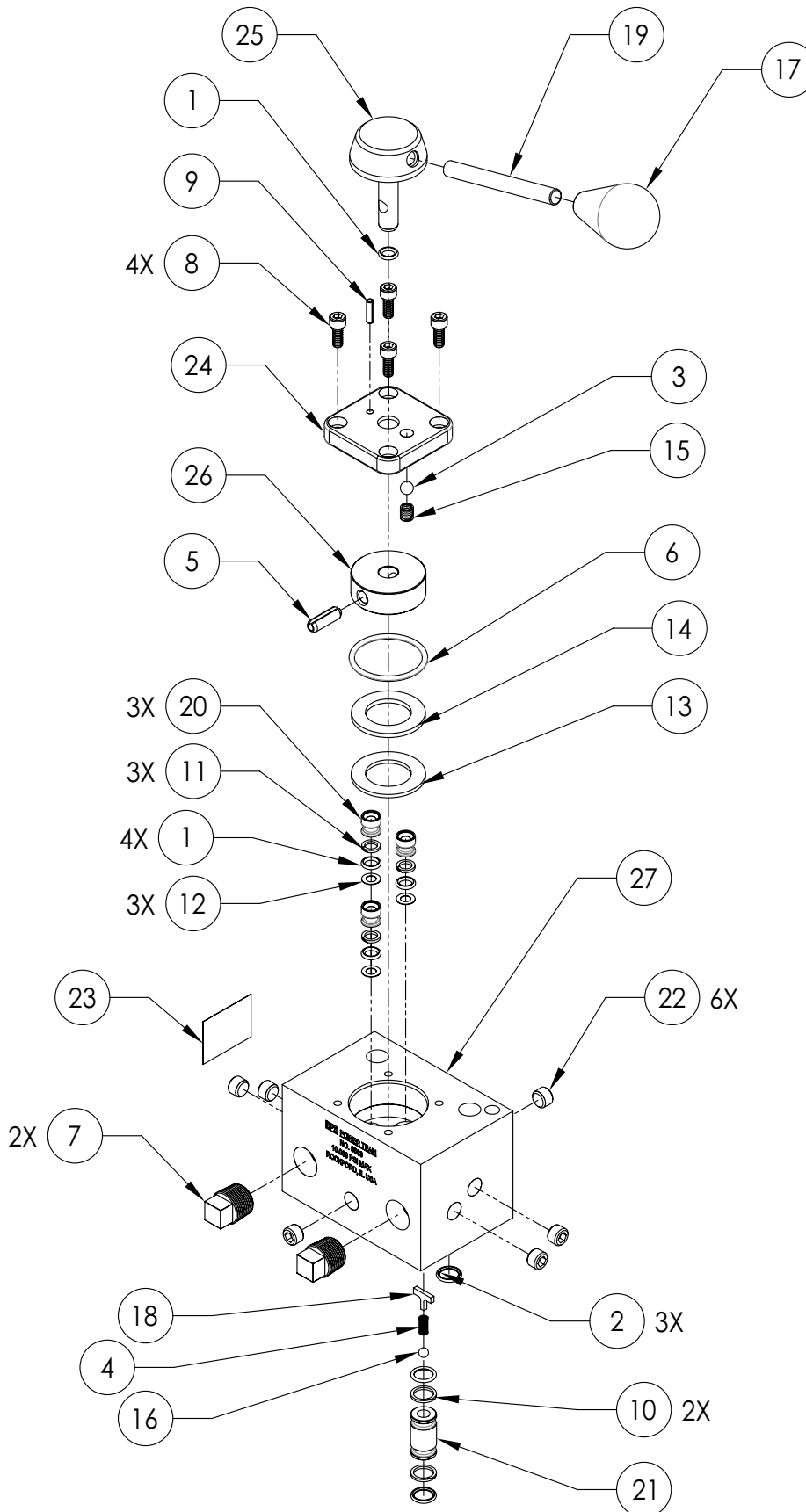

**Parts List continued**

ITEM NO.	PART NO.	DESCRIPTION	QTY.
1	10266	O-RING (-010) 0.239IDx0.070 NITRILE 70	4
2	10268	O-RING (-012) 0.316 ID x 0.070 NITRILE 70	3
3	10375	BALL, 1/4" DIA STEEL	1
4	10445	SPRING COM. OD .166I.D. XXXR .580 751MW	1
5	10716	PIN, SLOTTED SPRING STANDARD DUTY	1
6	10930	O-RING (-125) 1.299ID X 0.103 NITRILE 70	1
7	11127	FITTING, PLUG 3/8 NPTF W/SEALANT	2
8	11434	SCREW, SOCKET HD CAP - #10-24 X 0.50	4
9	11587	PIN, SLOTTED SPRING, STANDARD DUTY	1
10	11863	WASHER, BACKUP 0.50 x 0.375	2
11	12184	WASHER, BACKUP 0.375 x0.250	3
12	12187	WASHER, SPRING	3
13	12188	ROLLER THRUST BEARING	1
14	12189	WASHER, THRUST 1.420 x0.880	1
15	12195	COMPRESSION SPRING	1
16	12223	BALL, 3/16" DIA STEEL	1
17	12821	KNOB	1
18	209795	STOP, OUTLET BALL	1
19	24564	STUD	1
20	24570	SHEAR SEAL	3
21	251128	BUSHING, OUTLET CHECK	1
22	251279	FITTING, PLUG 1/8 PTF	6
23	251512	DECAL, TELEPHONE INFORMATION	1
24	25821	COVER, VALVE - MACHINED	1
25	32070	STEM	1
26	32071	ROTOR	1
27	64374	BODY, VALVE	1

### 350623 (Body, Valve pressure Regulator)

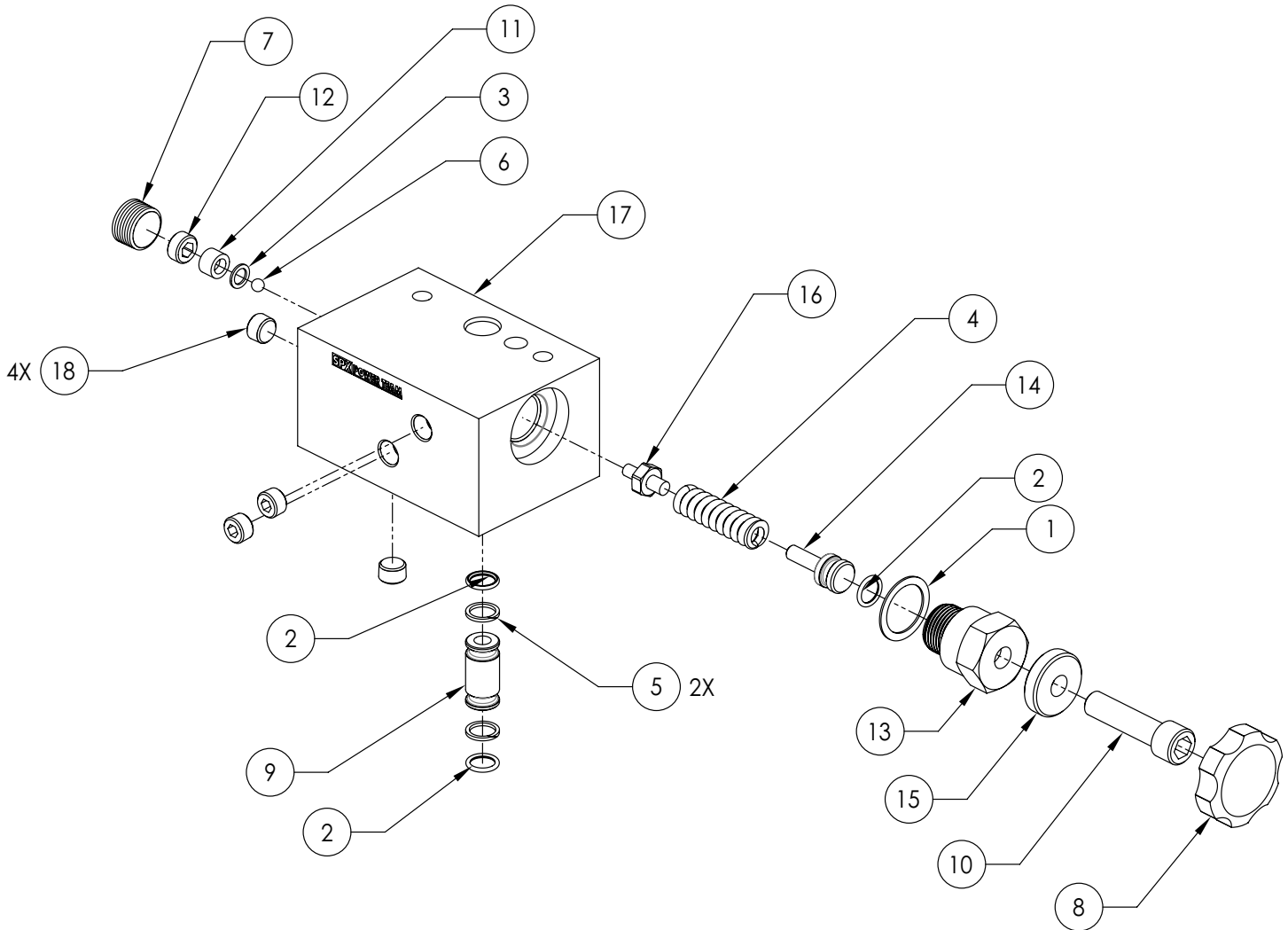

**Parts List continued**

ITEM NO.	PART NO.	DESCRIPTION	QTY.
1	10263	WASHER, PLAIN - SPECIAL	1
2	10268	O-RING (-012) 0.316 ID x 0.070 NITRILE 70	3
3	10442	WASHER, PLAIN 0.25X0.37X0.03 COPR	1
4	10495	SPRING, COMPRESSION	1
5	11863	WASHER, BACKUP 0.50 x 0.375	2
6	12223	BALL, 3/16" DIA STEEL	1
7	16232	PLUG, HEX FEMALE DRIVE - DRYSEAL	1
8	19564	KNOB, THUMB SCREW	1
9	202505	BUSHING	1
10	208148	SCREW, SHC - 3/8-24 x 1.5	1
11	209787	SEAT, REPLACEABLE	1
12	209797	SCREW, HOL LCK 7/16-20 X 0.25	1
13	21305	CAP, VALVE	1
14	21306	GUIDE, SPRING	1
15	215683	Regulator Locking Nut	1
16	350625	GUIDE, BALL	1
17	58350	BODY, VALVE PRESSURE REGULATOR	1
18	T1-1019-01	PLUG, 1/8-27 NPT FLUSH PLUMBING	4

**350720**  
(Manifold Assembly)

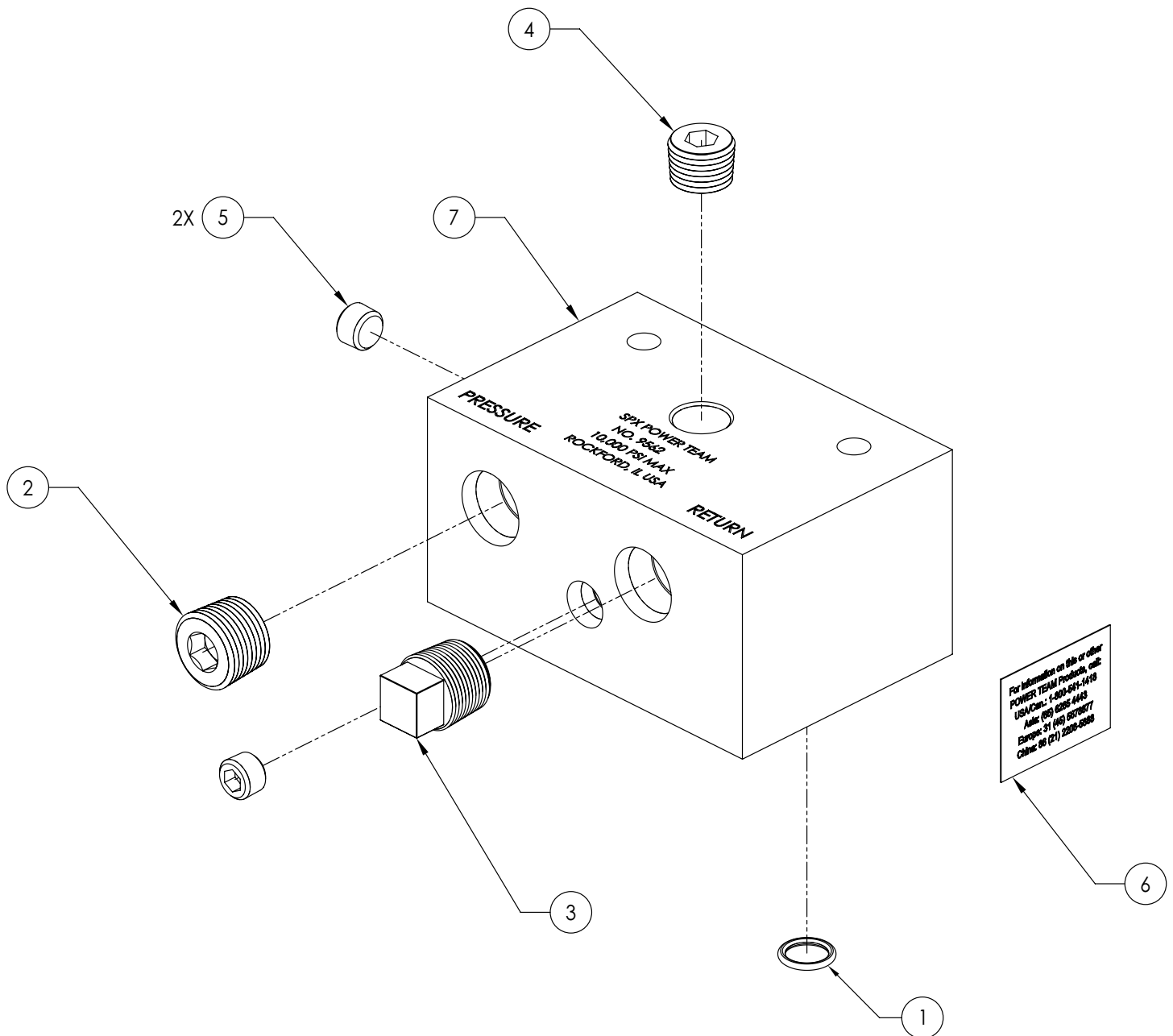

For information on this or other  
POWER TEAM Products, call:  
USA/Can.: 1-800-661-1418  
Asia: (85) 6285-4449  
Europe: 31 (40) 857877  
China: 86 (21) 2208-8288

ITEM NO.	PART NO.	DESCRIPTION	QTY.
1	10268	O-RING (-012) 0.316 ID x 0.070 NITRILE 70	1
2	10909	FITTING, PLUG - 3/8 NPTF M FLUSH	1
3	11127	FITTING, PLUG 3/8 NPTF W/SEALANT	1
4	14972	FITTING, PLUG - 1/4 PTF FLUSH	1
5	251279	FITTING, PLUG 1/8 PTF	2
6	251512	DECAL, TELEPHONE INFORMATION	1
7	58349	BODY, MANIFOLD	1

**3001123**  
(Manifold Assembly)

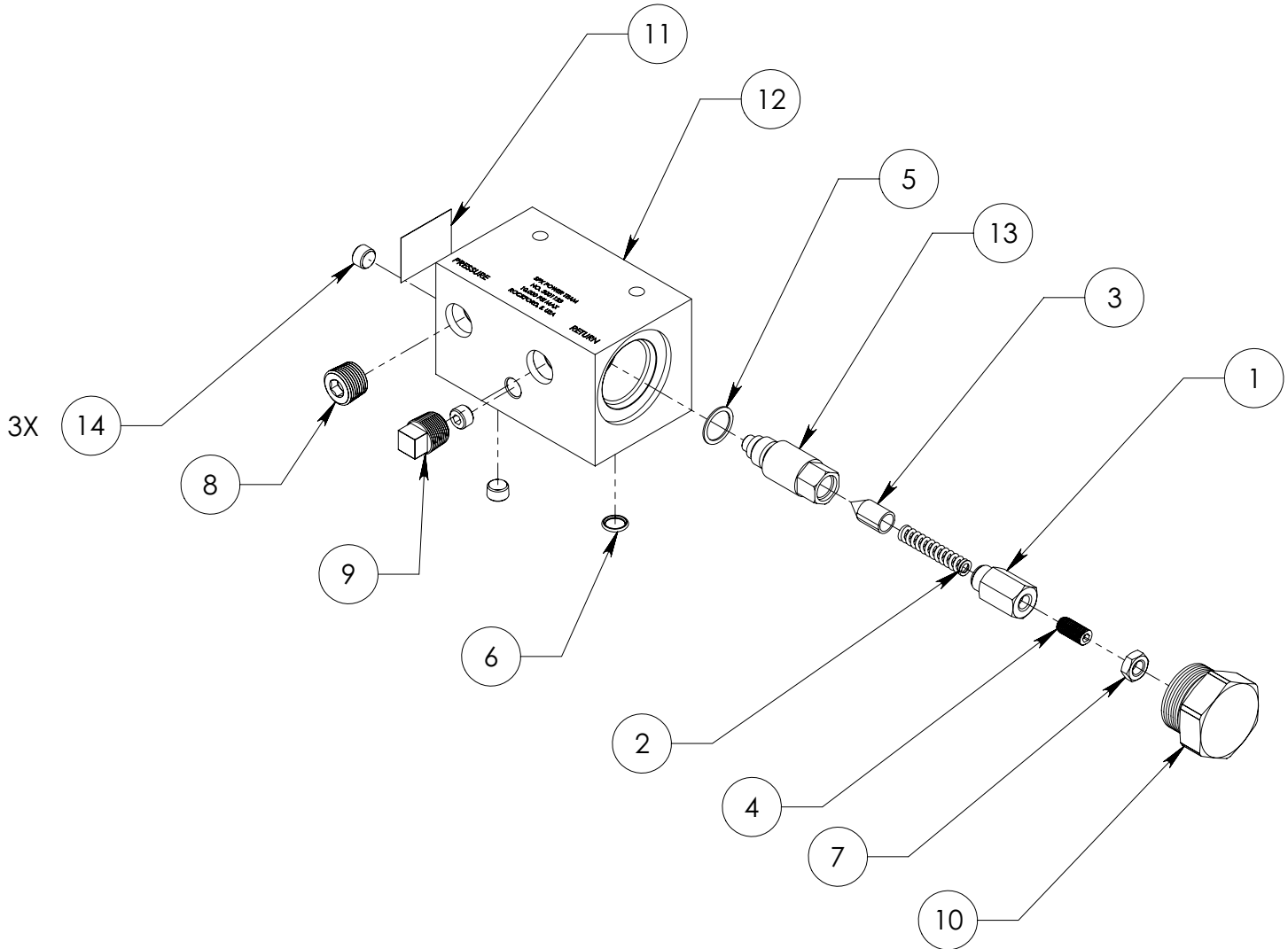

ITEM NO.	PART NO.	DESCRIPTION	QTY.
1	3-0651	CAP, VALVE	1
2	3-0653	SPRING COM OD.335IDX.XXXR493.5L1.675MW	1
3	3-0654	PLUNGER, VALVE	1
4	5-2891	SCREW, 5/16-24 X 0.63 SET CUP	1
5	10261	WASHER, PLAIN 0.60 x 0.75 x 0.03 COPR	1
6	10268	O-RING (-012) 0.316 ID x 0.070 NITRILE 70	1
7	10384	NUT, HEX JAM 5/16-24	1
8	10909	FITTING, PLUG - 3/8 NPTF M FLUSH	1
9	11127	FITTING, PLUG 3/8 NPTF W/SEALANT	1
10	207908	FITTING, PLUG 1-5/16-12 ORB	1
11	251512	DECAL, TELEPHONE INFORMATION	1
12	2010235	BODY, MANIFOLD	1
13	2010291	BODY, VALVE	1
14	T1-1019-01	PLUG, 1/8-27 NPT FLUSH PLUMBING	3



# ELECTRICAL SCHEMATIC

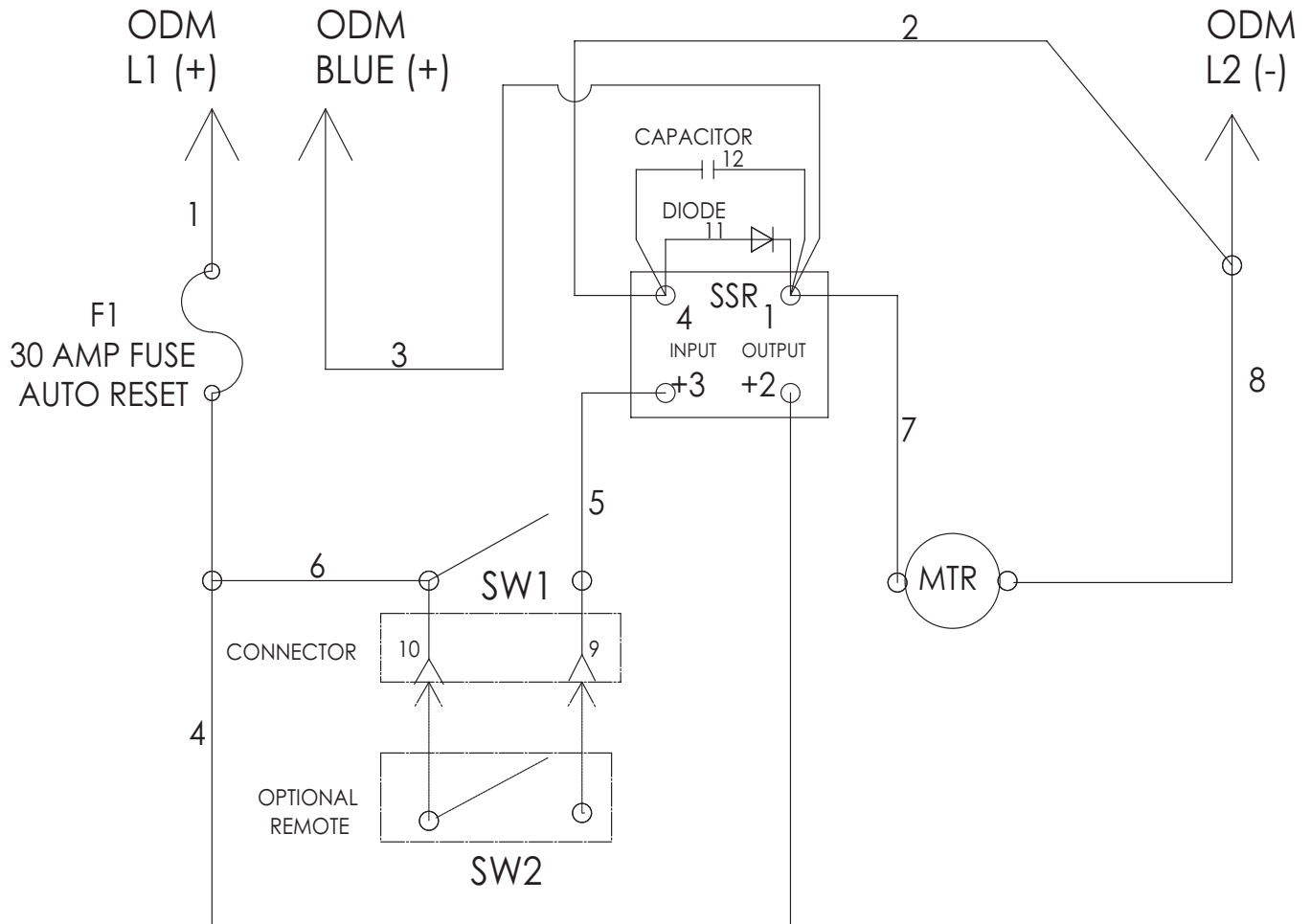

# HYDRAULIC SCHEMATIC

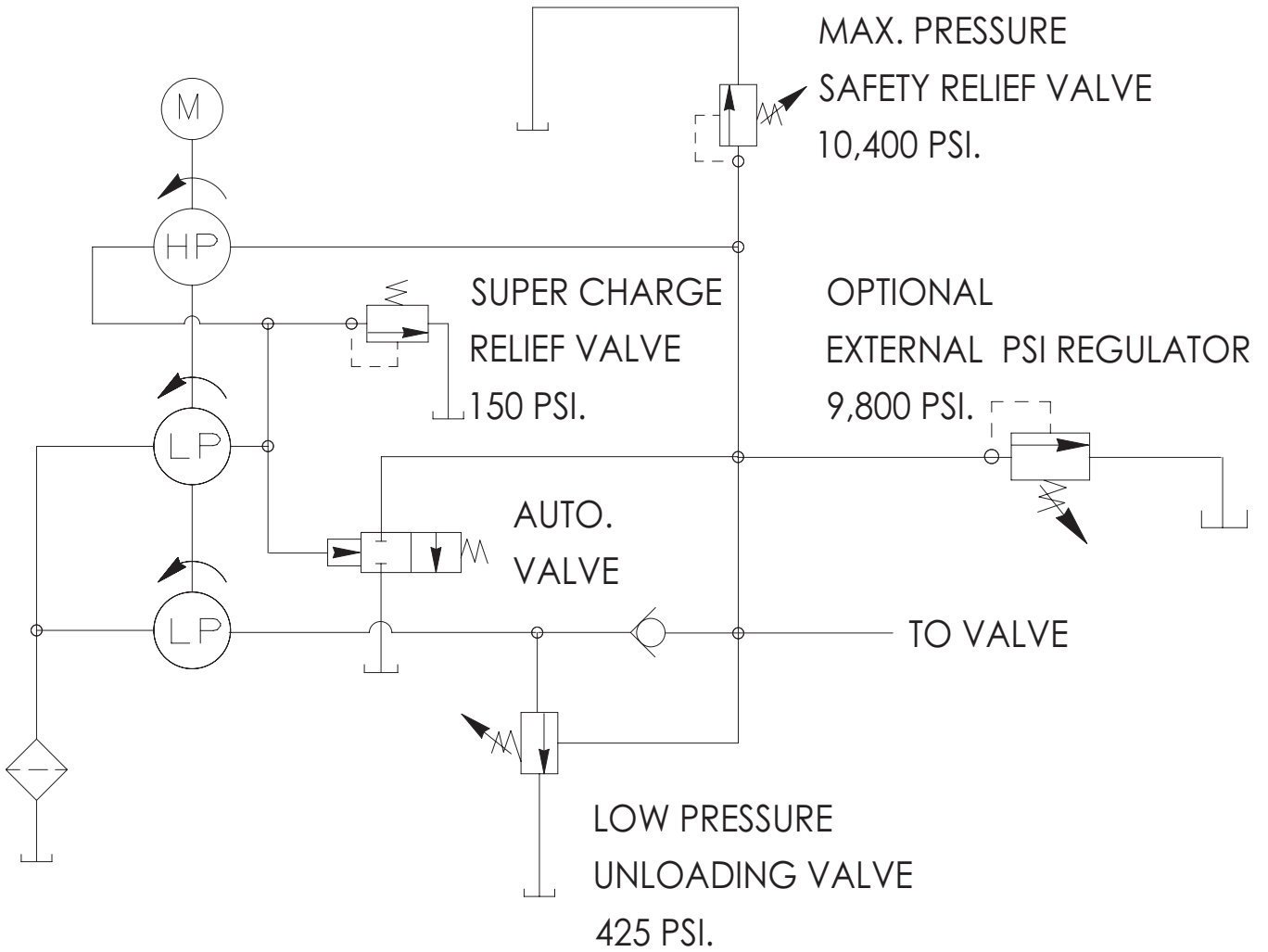

## POWER TEAM FACILITIES & CONTACT

---

### Rockford, Illinois USA

Customer Service/Order Entry  
Tel: +1 800 541 1418  
Fax: +1 800 288 7031

### Technical Services

Tel: + 1 800 477 8326  
Fax: + 1 800 765 8326  
info@powerteam.com

### European Headquarters

Tel: +31 45 567 8877  
Fax: +31 45 567 8878  
infoeurope@powerteam.com

### Shanghai, China

Tel: +86 21 2208 5888  
Fax: +86 21 2208 5682  
infochina@powerteam.com

### Asia Pacific Headquarters

Tel: +65 6265 3343  
Fax: +65 6265 6646  
infoasia@powerteam.com



[www.spxflow.com](http://www.spxflow.com)

SPX Flow Powerteam Customer Service:  
 (800) 541-1418

## MILWAUKEE TOOL CORPORATION CONTACT

---



[www.milwaukeetool.com](http://www.milwaukeetool.com)

Milwaukee Tool Customer Service:  
 (800) 729-3878

## EC DECLARATION OF CONFORMITY

We declare under our sole responsibility that our Electric Pump Model:

\*

**PB102, PB102P, PB102R, PB102A, PB104, PB102-1, PB102P-1, PB102R-1, PB102A-1, PB104-1, PB102-2, PB102P-2, PB102R-2, PB102A-2, PB102-CP, PB102-0, PB102P-0, PB102R-0, PB102A-0, PB104-0, PB104-2,**

to which this declaration relates are in conformity with the following:

### EN, EN-ISO, ISO standards

### Title

#### **Per the provisions of the Machinery Safety Directive**

#### **2006/42 EC**

EN_ISO 12100	Safety of machinery, basic concepts, general principles for design, risk assessment & risk reduction
EN 4413	Hydraulic Fluid Power – general rules and safety requirements for systems & their components

#### **Per the provisions of the EMC Directive**

#### **2014/30 EU**

EN_61000-4-2	Electromagnetic Discharge Immunity test
EN_61000-4-3 +A2	Radiated, Radio Frequency, Electromagnetic Field Immunity test
EN_61000-4-4	Electrical Fast Transient / Burst Immunity test
EN_61000-4-5	Surge immunity test
EN_61000-4-6	Immunity to Conducted Disturbances, Induced by Radio-Frequency Fields
EN_61000-4-11	Voltage Dip and Interrupt test
EN 55011	Industrial, Scientific and Medical (ISM) Radio Frequency Equipment-Electromagnetic Disturbance Characteristics-Limits and Methods of Measurement

#### **Per the provisions of the Battery Directive**

#### **2006/66/EC**

IEC 61960	Secondary Lithium Cells and Batteries for Portable Applications
-----------	---

#### **Per the provisions of the Noise Emission**

#### **2000/14 EC**

#### **in the Environment by Equipment for Use Outdoors Directive**

EN_3200L0014	Noise emission in the environment for use outdoors
ISO 3744	Sound Power Level Measurements

measured sound power level on an equipment representative for this type : 68 dB(A)  
guaranteed sound power level for this equipment : 74 dB(A) or less

#### **Per the provisions of the RoHS Directive**

#### **2015/863 EU**

Restriction of the use of certain hazardous substances in electrical and electronic equipment

We hereby declare that the equipment specified under \* conforms to the above quoted European Community Directive(s) and Standard(s) as per the currently valid revision. SPX Hydraulic Technologies is certified and registered to ISO 9001: 2015.

The Netherlands January 16<sup>th</sup>, 2019



-----  
Andreas J. Klemm, PhD

**SPX Hydraulic Technologies**  
5885 11<sup>th</sup> Street  
Rockford, IL 61109-3699  
United States of America

**SPX Hydraulic Technologies**  
Andreas J. Klemm  
SPX Hydraulic Technologies  
Albert Thijsstraat 12  
NL-6471 WX Eygelshoven  
The Netherlands