



TWO-STAGE HYDRAULIC HAND PUMP

Max. Pressure: See Pump Data Plate

Definition: A hydraulic hand pump delivers hydraulic fluid under pressure by directly applied manual effort.

Note: Illustration depicts general pump configurations.



For Use With	Part No.	Volume & Pressure					Handle Lever Effort		Reservoir				Product Weight		
		Stage	Volume per Stroke		Maximum Pressure		lbs.	kg	Type	Oil Capacity		Usable Oil Capacity		lbs.	kg.
			In. ³	cm ³	psi	bar				In. ³	cm ³	In. ³	cm ³		
Single-Acting Cylinders (Pump includes 2-Way Valve)	P59L-1500	1 2	0.68 0.05	11.2 0.88	300 22,500	20 1550	72	32.7	B	67.1	1100	44.5	730	10.4	4.7

9/16-18 Coned-and-Threaded Connection port(s) on all pumps

Table 1

SAFETY EXPLANATIONS

Two safety symbols are used to identify any action or lack of action that can cause personal injury. Your reading and understanding of these safety symbols is very important.

⚠ DANGER - Danger is used only when your action or lack of action will cause serious human injury or death.

⚠ WARNING - Warning is used to describe any action or lack of action where a serious injury can occur.

IMPORTANT - Important is used when action or lack of action can cause equipment failure, either immediate or over a long period of time.

Pictogram Definition



Do not remove this component. For service only. Pressure must be released.

⚠ WARNING : It is the operator's responsibility to read and understand the following safety statements,

- Only qualified operators should install, operate, adjust, maintain, clean, repair, or transport this equipment or machinery.
- These components are designed for general use in normal environments. These components are not specifically designed for lifting and moving people, agri-food machinery, certain types of mobile machinery or special work environments such as: explosive, flammable or corrosive. Only the user can decide the suitability of this equipment or machinery in these conditions or extreme environments. Power Team will supply information necessary to help make these decisions.
- Do not use equipment if damaged, altered, or in poor condition.
- All safety decals must be replaced when unreadable.

These instructions are intended for end-user application needs. Most problems with new equipment are caused by improper operation or installation. Detailed service repair instructions or parts lists can be obtained from your nearest Power Team facility.

SAFETY PRECAUTIONS

⚠ WARNING : To help prevent personal injury,

- Before operating the pump, all hose connections must be tightened with the proper tools. Do not overtighten. Connections need only be tightened securely and leak-free. Overtightening may cause premature thread failure or high pressure fittings to split at pressures lower than their rated capacities.
- Should a hydraulic hose ever rupture, burst, or need to be disconnected, immediately shut off the pump and shift the control valve twice to release all pressure. Never attempt to grasp a leaking hose under pressure with your hands. The force of escaping hydraulic fluid could cause serious injury.
- Do not subject the hose to any potential hazard such as fire, extreme heat or cold, sharp surfaces, heavy impact. Do not allow the hose to kink, twist, curl, or bend so tightly that the fluid flow within the hose is blocked or reduced. Periodically inspect the hose for wear because any of these conditions can damage the hose and result in personal injury.
- Do not use the hose to move attached equipment. Stress may damage the hose and fittings which could cause personal injury.
- Hose material and coupler seals must be compatible with the hydraulic fluid used. Hoses also must not come in contact with corrosive materials such as creosote-impregnated objects and some paints. Consult the manufacturer before painting a hose. Never paint the couplers. Hose deterioration due to corrosive materials may result in personal injury.
- All components in the hydraulic system must match the maximum pressure rating of the pump.

Pump

- Do not exceed the PSI rating noted on the pump nameplate or tamper with internal high pressure relief valve. Creating pressure beyond rated capacities may result in personal injury.
- Before adding hydraulic fluid, retract the system to prevent overfilling the pump reservoir. An overfill may cause personal injury due to excess reservoir pressure created when cylinders are retracted. **Only connect, or disconnect fully retracted cylinders to/from the pump.**
- The load must be under operator control at all times.
- Do not connect pump to hydraulic system powered by another pump.

Cylinder

- **Do not exceed rated capacities of the cylinders. Excess pressure may result in personal injury.**
- **Do not set poorly-balanced or off-center loads on a cylinder. The load may tip and cause personal injury.**
- **Stay clear of lifted loads and keep others away.**
- **Extensions are not recommended for lifting applications.**

SET-UP

Hydraulic Connections

IMPORTANT: The P59L-1500 series hand pump uses a compact coned-and-threaded connection for attaching hydraulic fittings. Follow the fitting manufacturer's specifications and recommended torque values when making connections using these types of fittings.

1. Clean all areas around the fluid ports of the pump and cylinder. Clean all hose ends, couplers, and union ends. Remove thread protectors from the hydraulic fluid outlets, and connect the hose assembly. Couple hose to cylinder, making sure couplers are fully engaged.
2. The use of a hydraulic pressure or tonnage gauge (included on P59L-1500G) is strongly recommended. Remove the plug from the gauge port of the pump and install the gauge according to the manufacturer's specifications and recommended torque values.

⚠ WARNING : To help prevent personal injury,

- The gauge must have the same pressure rating as the pump and cylinder. Personal injury can result if the wrong gauge is used.
- Release hydraulic pressure BEFORE removing or tightening hose couplings.

OPERATION

The P59L-1500 hand pump can be operated in a horizontal position or in a vertical position with the head of the pump pointing downward.

IMPORTANT: Figure 1 illustrates the normal drop of handle effort experienced when two-stage pumps shift from low pressure stage to high pressure stage.

Two-way Valve

Pumps with a two-way valve are for use with single-acting cylinders.

1. To extend the cylinder, turn the valve knob clockwise to a closed (seated) position.

Note: Hand tight only! Work the pump handle up and down to build pressure.

2. To release pressure, open the valve slowly by turning the knob counterclockwise to control the load.

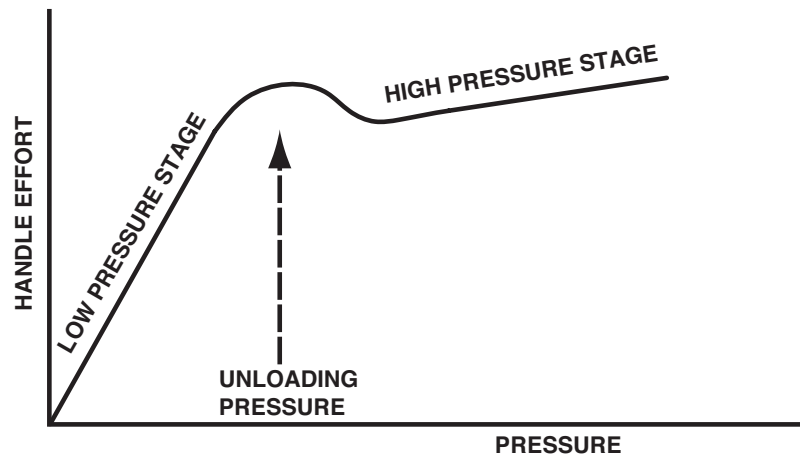

Figure 1

⚠ WARNING : The operator should always release the pressure slowly.

PREVENTIVE MAINTENANCE

IMPORTANT: Any repair or servicing that requires dismantling the pump must be performed in a dirt-free environment by a qualified technician.

Lubrication

Apply lubricant regularly to all pivot and rubbing points.
Use a good grade of No. 10 motor oil or grease. Do not use dry lubricants.



Bleeding Air From the System

Air can accumulate in the hydraulic system during the initial set-up or after prolonged use, causing the cylinder to respond slowly or in an unstable manner.

To remove the air:

1. Position the cylinder at a lower level than the pump, and turn the cylinder rod end down.
2. Extend and retract the cylinder several times without putting a load on the system. Air will be released into the pump reservoir. Follow the fluid level instructions for your reservoir type to release the air from the reservoir and top off the fluid supply.

Bleeding Air From The Pump

When the pump is first put into use, or after refilling the pump's reservoir it may be necessary to bleed any trapped air from the pump. If this is not done the pump will not function properly (will not build pressure or has very spongy operation).

To remove the air:

1. Turn the pressure control knob counterclockwise (CCW) (open position) and operate the pump handle up and down approximately twenty times.
2. Turn the pressure control knob clockwise (CW) (closed position) to its full stop position.

Note: Hand tight only!

3. The pump should now be bled of air and ready to use.

Hydraulic Fluid Level

⚠ WARNING : Cylinder(s) connected to the pump must be fully retracted before checking the fluid level.

Release all system pressure before breaking any hydraulic connection in the system.

Check the hydraulic fluid level in the reservoir periodically. Use a funnel with a filter to add hydraulic fluid if needed.

P59L-1500 (Reservoir Type B) :

Remove the filler cap. The fluid level should come to the bottom edge of the filler hole when the pump is level and resting horizontally on its base and the cylinders are retracted (see Figure 2).

Draining And Flushing The Reservoir

Drain, clean and replenish the reservoir with high-grade, approved Power Team hydraulic fluid yearly or more often if necessary. The frequency of fluid change will depend upon the general working conditions, severity of use and overall cleanliness and care given the pump.

IMPORTANT: Clean the exterior of the pump first. After draining and flushing the reservoir, drain and clean the other hydraulic system components (hoses, cylinders, etc.) before connecting them to the pump again. This will help prevent contaminated fluid from entering the pump.

1. Remove the filler cap. Drain the hydraulic fluid through filler hole.
2. Remove the nut from the tie rod. Separate the reservoir from the pump body. Clean the reservoir and filter.
- **IMPORTANT:** Removing the filter from the pump assembly could result in its breakage. Attempt to clean it as well as possible with it installed.
3. Reassemble and fill the reservoir with Power Team hydraulic fluid. Replace the filler cap.

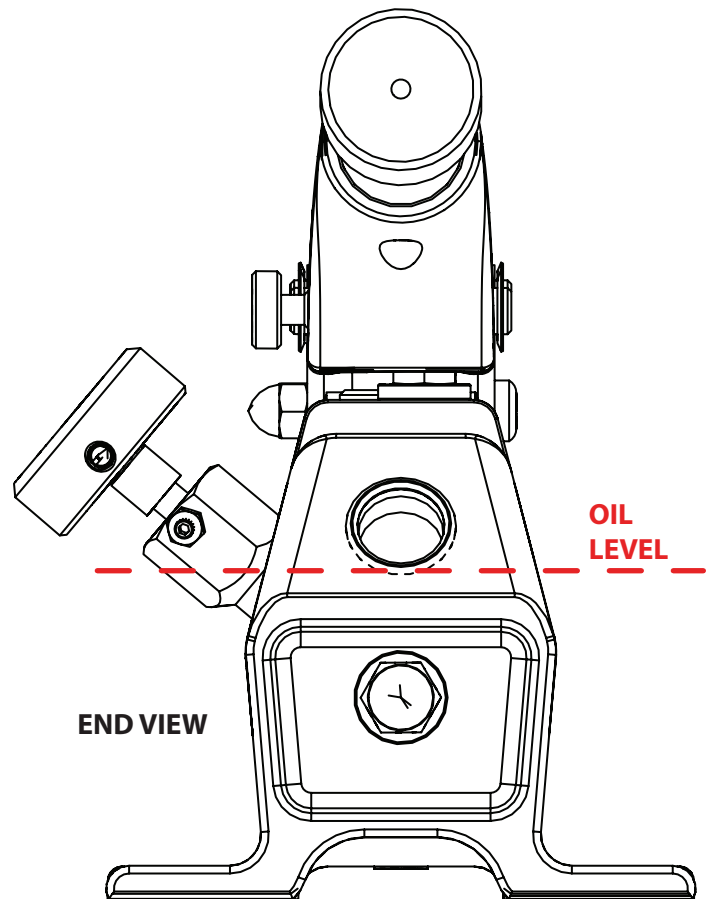

FIGURE 2

TROUBLESHOOTING GUIDE

⚠ WARNING : To help prevent personal injury, always release pump pressure and disconnect hoses(s) from pump before making repairs.

Refer to the appropriate pump parts list during trouble-shooting. Repairs must be performed in a dirt-free environment by qualified personnel familiar with this equipment.

PROBLEM	CAUSE	SOLUTION
Pump losing pressure	<ol style="list-style-type: none"> 1. System components leaking 2. Directional control valve leaks or not adjusted properly 3. Fluid leaking past outlet check seat(s) 	<ol style="list-style-type: none"> 1. Repair or replace as necessary 2.* Reseat, repair, or replace directional control assembly and correctly adjust 3.* Check for dirt. Reseat pump body and/or replace poppet(s) or ball(s)
Handle rises after each stroke	<ol style="list-style-type: none"> 1. Fluid leaking past outlet check seat(s) 	<ol style="list-style-type: none"> 1.* Check for dirt. Reseat pump body and/or replace poppet(s) or ball(s)
Pump not delivering fluid	<ol style="list-style-type: none"> 1. Low fluid level in reservoir 2. Intake filter is dirty 3. Seats worn and not seating properly 	<ol style="list-style-type: none"> 1. Check fluid level per instructions 2. Remove reservoir and clean 3.* Repair seats or replace pump body
Pump does not reach full pressure	<ol style="list-style-type: none"> 1. Low fluid level in reservoir 2. System components leaking 3. Directional control valve leaks or not adjusted properly 4. Improperly adjusted relief valve 5. Fluid leaking past inlet or outlet checks or high pressure piston seal damaged 	<ol style="list-style-type: none"> 1. Check fluid level per instructions 2. Repair or replace as necessary 3.* Reseat, repair, or replace directional control assembly and correctly adjust 4.* Readjust 5.* Reseat or repair inlet or outlet checks or replace high pressure piston seal
Pump handle can be pushed down (slowly) without raising the load	<ol style="list-style-type: none"> 1. Inlet checks are not seating 2. Damaged piston assembly or piston seals leaking 	<ol style="list-style-type: none"> 1.* Check for dirt and/or reseat valve seats 2.* Replace piston assembly and/or piston seals
Pump handle operates with a spongy action	<ol style="list-style-type: none"> 1. Air trapped in system 2. Too much fluid in reservoir 	<ol style="list-style-type: none"> 1. Position cylinder lower than pump. Extend and return cylinder several times. Follow bleeding instructions. 2. Check fluid level per instructions
Pump handle effort drops significantly after some pressure has been obtained	<ol style="list-style-type: none"> 1. This is normal operation on most two-stage hand pumps 	

*Power Team recommends these hand pump repairs be performed by an Authorized Hydraulic Service Center.

POWER TEAM FACILITIES & CONTACT

Rockford, Illinois USA

Customer Service/Order Entry
Tel: +1 800 541 1418
Fax: +1 800 288 7031

Technical Services

Tel: + 1 800 477 8326
Fax: + 1 800 765 8326
info@powerteam.com

European Headquarters

Tel: +31 45 567 8877
Fax: +31 45 567 8878
infoeurope@powerteam.com

Shanghai, China

Tel: +86 21 2208 5888
Fax: +86 21 2208 5682
infochina@powerteam.com

Asia Pacific Headquarters

Tel: +65 6265 3343
Fax: +65 6265 6646
infoasia@powerteam.com



www.spxflow.com

SPX Flow Customer Service:

 **(800) 541-1418**

California Proposition 65 Warning

This product contains or may contain chemical(s) known to the state of California to cause cancer or other reproductive effects.

DECLARATION OF INCORPORATION OF PARTLY COMPLETED MACHINERY

We declare under our sole responsibility that our Hand-Pump Models:

62072,	201338-TID,	P157,
62087,	P12,	P157D,
64122,	P19,	P159,
64215,	P19L,	P159D,
64372,	P23,	P300,
66463,	P30F,	P300D,
64662,	P55,	P460,
64663,	P59,	P460D
YM-01,	P59L,	P59L-1500
	P59F,	P59L-1500G

to which this declaration relates are in conformity with the following:

<u>EN, EN-ISO, ISO standards</u>	<u>Title</u>
Per the provisions of the Machinery Safety Directive	2006/42 EC
EN_ISO 12100:2011	Safety of machinery, basic concepts, general principles for design, risk assessment & risk reduction
EN 4413:2010	Hydraulic Fluid Power – general rules and safety requirements for systems & their components

We, the undersigned, hereby declare that the equipment specified above conforms to the above mentioned European Communities Directive(s) and Standard(s).

SPX Hydraulic Technologies
5885 11th Street
Rockford, IL 61109-3699
United States of America

This product is not to be put into service until the final machine into which it is to be incorporated has been declared in conformity with the provisions of these Directives, where appropriate.

SPX Hydraulic Technologies
Andreas J. Klemm
SPX Hydraulic Technologies
Albert Thijsstraat 12
NL-6471 WX Eygelshoven
The Netherlands

The Netherlands Sept 14, 2017



Andreas J. Klemm, PhD