

# SPXFLOW

## >Power Team®

SPX Hydraulic Technologies  
5885 11th Street  
Rockford, IL 61109-3699 USA  
powerteam.com

Tech Services: (800) 477-8326  
Fax: (800) 765-8326  
Order Entry: (800) 541-1418  
Fax: (800) 288-7031

Parts List for:

**RDG Series**  
**RGG Series**  
**RGL Series**

### 100 TON HYDRAULIC CYLINDER DOUBLE-ACTING, SINGLE-ACTING, & LOCKING COLLAR

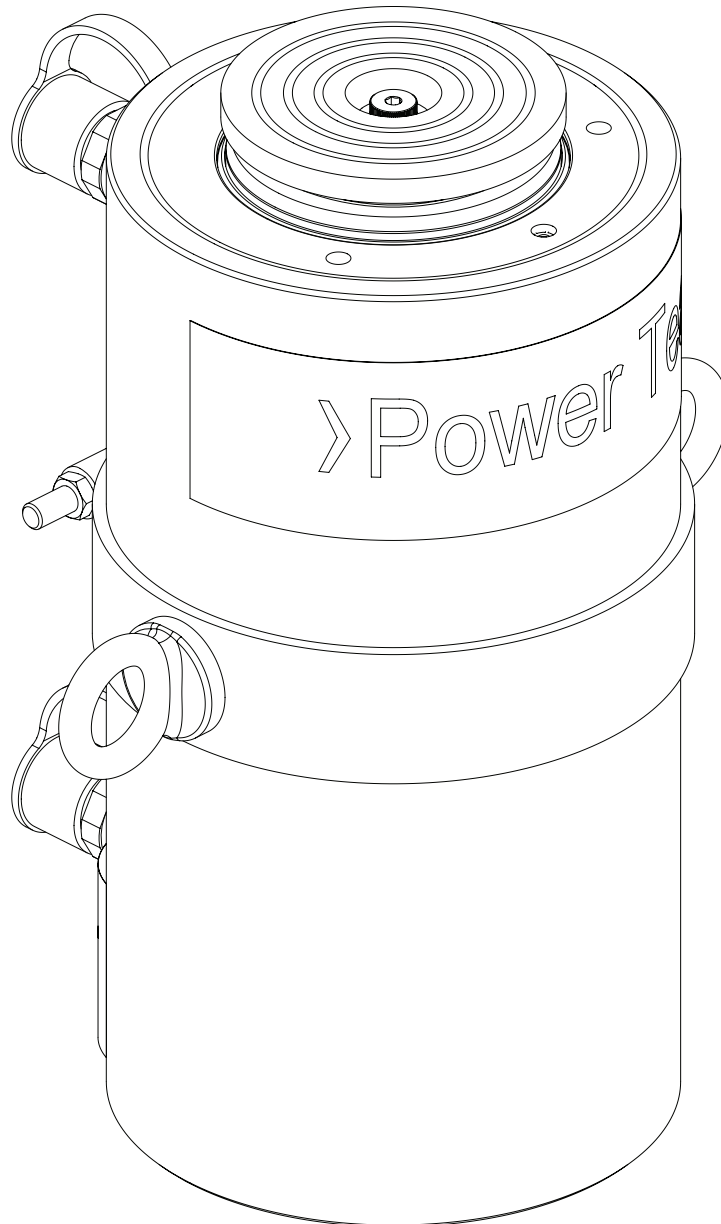

# PARTS DIAGRAM

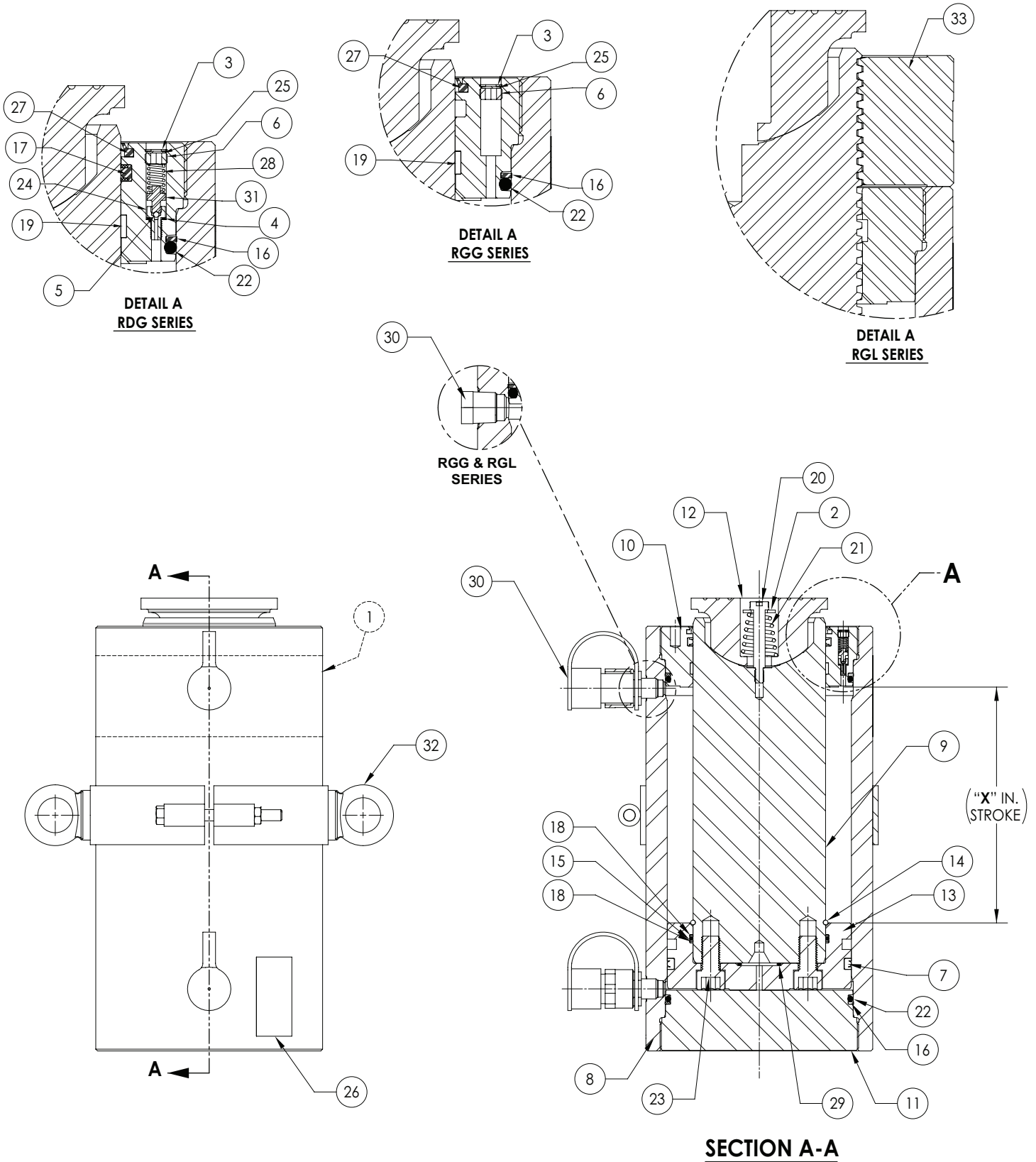

## PARTS LIST

ITEM	PART NO.	DESCRIPTION	QTY.
1	1000934	DECAL, TRADENAME POWERTEAM (2.75 X 10.25)	1
2	10258	WASHER	1
3	12201	RING, RETAIN INT 0.18 X .010	1
4	14319	WASHER, SPECIAL 0.310 x0.190	1
5	17238	BALL, 3/32 DIA STAINLESS STEEL	1
6	17240	SCREW, HOL LCK 3/8-24 X 0.19	1
7	19207	T-SEAL, 5.13 x 4.63 x 0.36 L (-426)	1
8	2009138-X	CYLINDER, XIN 100T DA ST FNC	1
9	2009162-X	ROD, XIN 100T DA ST FNC SWVL	1
	2009521-X	ROD, XIN 100T LC ST FNC SWVL (RGL SERIES)	1
10	2009181	NUT, RETAINER 100T ST FNC	1
	2009528	NUT, RETAINER 100T LC ST FNC (RGL SERIES)	1
11	2009184	END, RETAINER 100T ST FNC	1
12	2009187	CAP, SWIVEL 100T ST FNC	1
13	2009190	PISTON, 100T DA ST FNC	1
14	2008402	WIRE, STOP 0.125	1
15	211019	O-RING (-240) 3.734 ID X 0.139 NITRILE 90	1
16	2008381	WASHER, BACKUP 5.25 x 5.00 (HYTREL)	2
17	250007	T-SEAL, 4.13 x 3.75 x 0.27 L (-343)	1
18	2008401	WASHER, BACKUP 4.00 x 3.75 (HYTREL)	2
19	2009255	WIPER,FELT HARD-DENSITY	1
20	2009258	SCREW, SHOULDER M8 X 1.25 - 40MM	1
21	212000	SPRING COM OD1.025ID.667R32L1.680CS	1
22	2009379	ORING, -250 4.984INx0.139x5.262 NBR70	2
23	2009307	SCREW, CAP M14 X 30MM	4
24	203364	SEAT, REPLACEABLE	1
25	203475	SCREEN, FILTER	1
26	203908	DECAL, WARNING CYLINDER	1
27	250008	WIPER, ROD 4.12 X 3.75 URE	1
28	209260	SPRING, COM OD .308 ID X.XXXR69L.645MW	1
29	250815	O-RING (-217) 1.171x0.139	1
30	25600	COUPLER, QUICK CYLINDER HALF	2
	4796-AA	BREATHER VENT 3/8 N.P.T. (RGG & RGL SERIES)	1
31	29785	RETAINER, BALL	1
32	58486-OR9	HANDLE, CYLINDER LIFT 6.5 ID.	1
33	2009526	COLLAR, 100T LC ST FNC (RGL SERIES)	1

## SEAL KITS

- For RDG100 Series use Seal Kit No. 3000876
- For RGL100 Series use Seal Kit No. 3001028
- For RGG100 Series use Seal Kit No. 3001018