

**Assembly &****Operating Instructions for:**

1868

1869

SPE15013DS

SPE20013DS

SPF200

## Shop Press

Max. Capacity: 150/200 Ton (334.4/1779.2 k N)

The movable work head offers off-center pressing with no loss of pressing capacity. The upper bolster can be lowered 11 inches (279.4 mm), and open sides permit easy loading and unloading of material.

### Safety Precautions

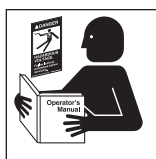
**WARNING To prevent personal injury,**

- Read and carefully follow these operating instructions and safety precautions before assembling or using the press. Read and carefully follow the operating and safety precautions for the pump and the ram used with the press. Most problems with new equipment are caused by incorrect operation or assembly.
- The owner of the press must see that it is installed and operated according to federal (OSHA), state, and local safety standards.
- A press can exert an extremely high force at a moderate hydraulic pump pressure. If you have any questions about how much force is exerted at a given pressure, contact Technical Services.
- This press is designed for shop maintenance applications. For more information about other applications, contact Technical Services.
- Wear protective eyewear that meets the requirements of ANSI Z87.1 and OSHA.
- Locate the press in an isolated area or shield it to minimize danger to others; hydraulic pressure can cause materials to break, possibly resulting in personal injury.

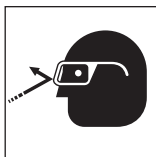

- It is impossible for the manufacturer to provide practical "all-purpose" shielding because this is a general-purpose press that can be used in many different applications. The owner of the press must supply shielding that is practical and necessary for a particular application. Some safety is provided by wrapping the work in heavy cloth (such as canvas) before applying pressure.
- Work pieces must be well supported and aligned so when pressure is exerted, parts being pressed do not slip out or break.
- To prevent accidental slippage, do not place work pieces on the press bed, or apply hydraulic force, until all bolster pins are in place and all tension has been removed from the bolster 11ft cables.
- Do not stress adapters beyond their capacities. Pushing or pulling adapters used with this press must have a maximum tonnage rating equal to, or higher than, the maximum tonnage rating of the press, or breakage can occur.
- The owner of the press must replace all safety-related decals if they become too hard to read.

## Safety Precautions cont'd.

**BOLSTER ADJUSTMENT:** A winch and cable assembly supports the bolster when the bolster support pins are not in place. The following warnings must be observed to prevent personal injury:



- Keep hands, feet, etc. out from under the bolster. Accidental slippage can result in personal injury.
- To prevent slippage, all bolster support pins must be in place and all cables slack before a pressing operation is performed.
- To prevent cable breakage, never raise or lower the bolster while it holds a load.
- When raising or lowering the bolster, place support pins in all the way through the front and back uprights in the highest hole under the bolster that will not interfere with the new bolster position. Remove your hands from the support pins after the pins are in place to avoid personal injury if the bolster falls.
- Inspect the entire length of the lifting cables at least every three months. Replace any cable that appears frayed, worn, or crushed. The cables must run on the pulleys easily, and the pulleys must be free to turn. Correct cable maintenance will help prevent cable breakage.



## Assembly

(Refer to Parts List #100469)

1. Remove banding from press and shipping pallet. Remove all cartons
2. Assemble two foot angles to press frame. Slowly stand press upright, being careful that the weight and motion of the press do not carry it completely over backward.
3. Remove lock ring and spring from winch handle. Turn handle 180°. Assemble lock ring and spring again.
4. Attach pump-mounting bracket using two hex head cap screws and nuts. See Figure 1.
5. Place pump on bracket. Thread four machine screws through bracket into bottom of pump reservoir.
6. Clean the threads on the gauge, fittings, and hoses. Assemble hoses to pump as shown in Figure 2.

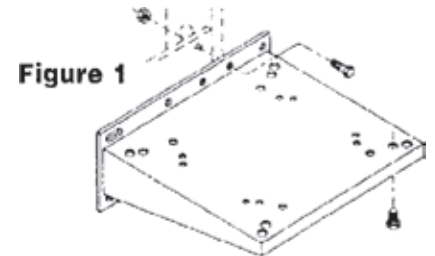

**IMPORTANT; Use a high grade, non-hardening pipe sealer to seal hydraulic connections. PTFE tape may be used if only ONE layer of tape is used. Leave first thread exposed (no tape). Apply carefully to prevent tape from being pinched by the fitting and braking off inside the pipe end. Loose pieces of tape could travel through the system and possibly obstruct the flow of oil.**

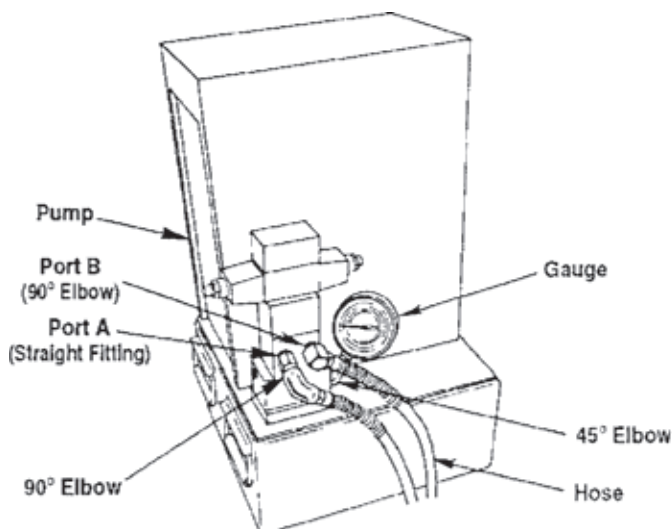

Figure 2

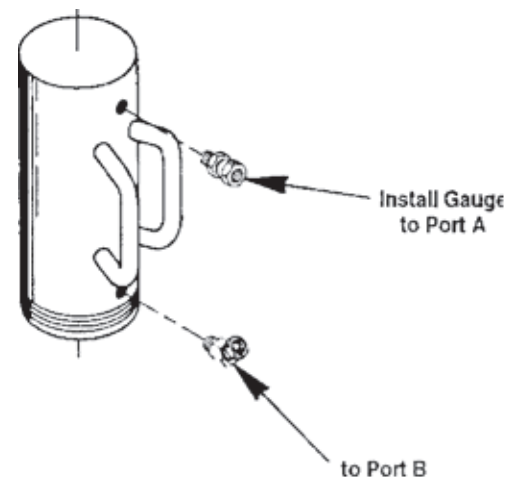

Figure 3

7. The gauge can be mounted to the pumps gauge port with a 45-degree elbow as shown in Figure 2. The gauge can also be mounted at the ram between the swivel fitting and the hose by using a tee adapter (not included) in the top swivel fitting. See Figure 3. In this case, install a pipe plug in the pump's gauge port.

8. Assemble hoses to the ram. Connect pump's valve port "A" to the fitting farthest away from the piston rod end of the ram. Connect valve port "B" to the fitting closest to the piston rod end. Refer to Figures 2 & 3.

9. Air can accumulate in the hydraulic system during initial setup or after prolonged use, causing the ram to respond slowly or in an unstable manner. To remove the air, lay the ram on the floor. Extend and retract the ram several times without putting a load on the system. Air will be released through the pump reservoir.

10. Position the work bed (bolster):

A. Crank the winch to put a small amount of tension on the cable and take weight off the pins.

B. Pullout the pins at the end of the bolster next to the winch. Insert pins below the bolster again, but in a position where they will not interfere with the desired bolster position. This will prevent the bolster from dropping all the way down if the Spacer cables or winch should fall.

C. Raise other end of bolster by pulling slightly on the handle until the two remaining pins are free. Remove those pins.

D. Crank the winch for either up or down movement of the work bed. Assemble the pins in the reverse order.

**IMPORTANT:** The winch has a special friction brake for holding the bolster during positioning. The friction brake is NOT designed to hold during a pressing operation, nor will it hold a workload during positioning.

11. Assemble the ram and mounting plate to the shop press:

A. Disassemble hoses from the ram. Plug hose ends and ram's, swivel fittings.

B. Thread ram into mounting plate. See Figure 4. **NOTE:** The ram handle must not interfere with the winch cable after mounting plate and ram are installed. See Figure 5. Position ram so swivel fittings point to the side of the press where the pump is mounted.

C. Assemble ram-mounting parts as shown in Figure 4, and position the assembly on the upper bolsters.



**WARNING** To prevent personal injury, the ram **MUST** be completely threaded into the mounting plate to prevent the threads from stripping when the press is under full load.

12. Due to the weight of the mounting plate and ram assembly, the lower bolster can be used with cribbing to raise the mounting plate and ram to the top bolster. **IMPORTANT:** The lower bolster should be used in this manner only during the assembly of the press because raising and lowering the bolster with a load can cause cable breakage.

13. Fasten mounting plate (with ram) to threaded rods using spacers and roll pins. Remove cribbing.

14. Attach hoses to ram again with pump's port "A" connected to the fitting farthest away from ram's piston rod end.

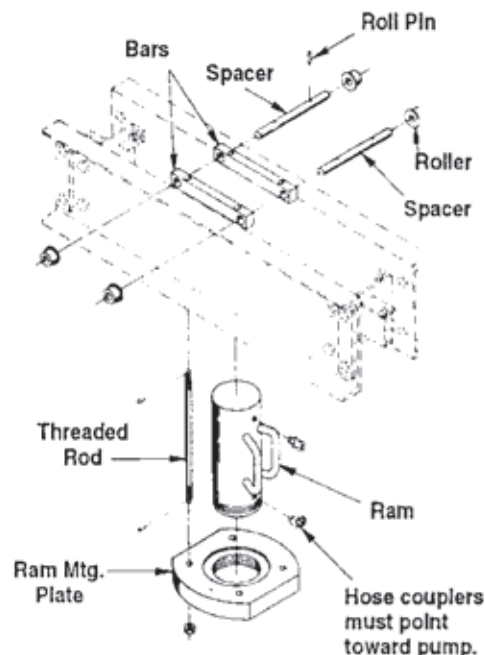

Figure 4

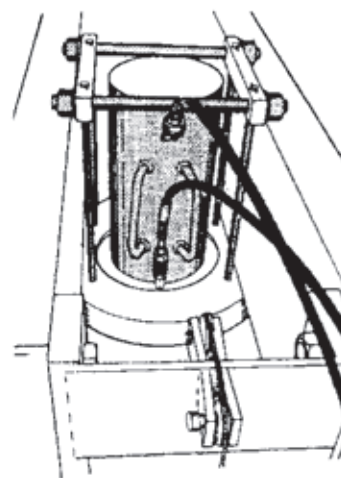

Figure 5