

MODELS A, B, C, D, & F
3 POSITION, 4-WAY MANUAL
CONTROL VALVE
(With "B" Port Pressure Control & Release System)
Max. Capacity: 10,000 PSI

Specifications	
Max. Working Pressure	10,000 PSI
"B" Port Return Pressure	5,800 - 6,400 PSI
Max. Flow Rating	5 GPM
Max. Valve Case Pressure (Return Tank Line)	500 PSI
Port Sizes	3/8 NPTF

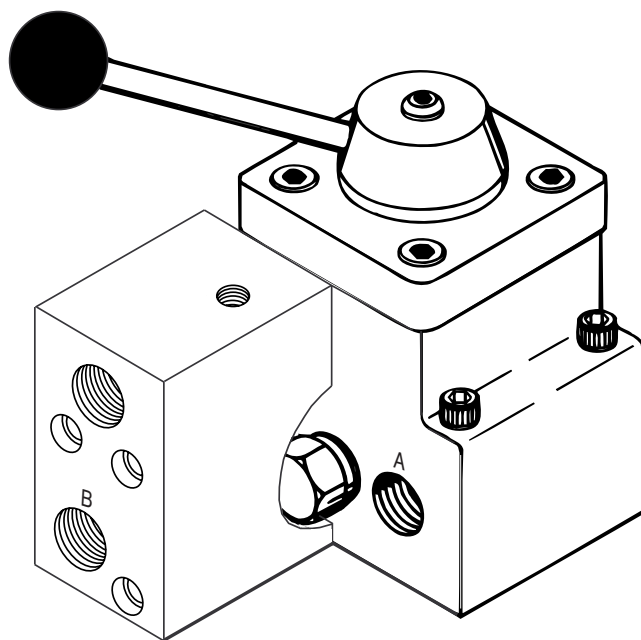

SAFETY PRECAUTIONS

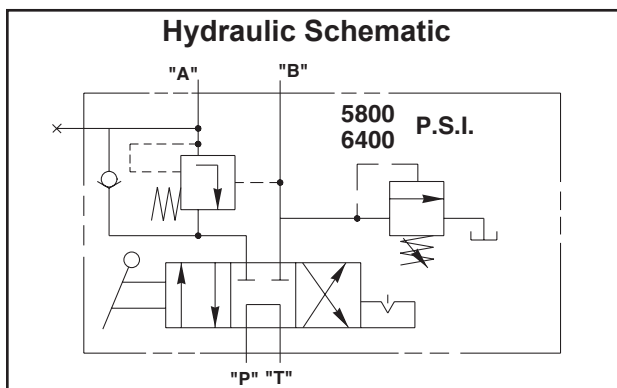

WARNING: To help prevent personal injury,

- All hose connections must be tightened with the proper tools before operating the pump. Do not overtighten. Connections should only be tightened securely and leak-free. Overtightening can cause premature thread failure or high pressure fittings to split at pressures lower than their rated capacities.
- Should a hydraulic hose ever rupture, burst or need to be disconnected, immediately shut off the pump and shift the control valve twice to release all pressure. Never attempt to grasp a leaking pressurized hose with your hands. The force of escaping hydraulic fluid could cause serious injury.
- Do not subject the hose to potential hazard such as fire, heavy impact, sharp surfaces, or extreme heat or cold. Do not allow the hose to kink, twist, curl, or bend so tightly that the oil flow within the hose is blocked or reduced. Periodically inspect the hose for wear, because any of these conditions can damage the hose and possibly result in personal injury.
- Do not use the hose to move attached equipment. Stress can damage the hose and possibly cause personal injury.
- Hose material and coupler seals must be compatible with the hydraulic fluid used. Hoses also must not come in contact with corrosive materials such as creosote-impregnated objects and some paints. Consult the manufacturer before painting a hose. Never paint the couplers. Hose deterioration due to corrosive materials can result in personal injury.

OPERATING PROCEDURE

NOTE:

- This valve has a low-torque design for use with either single-acting or double-acting cylinders.
- Move the valve handle to any position by loosening the cap screw and rotating the stem in increments of $22\ 1/2^\circ$ to the position desired. Torque the cap screw 60/80 in. lbs. See Figure 1.

1. Remove the port plugs from the pump, valve and cylinder.
2. Apply a high quality, nonhardening pipe thread sealant or PTFE tape to the external threads of all hydraulic connections. **IMPORTANT: Use only one layer of PTFE tape. Apply tape carefully, two threads back, to prevent it from being pinched by the fitting and broken off inside the pipe end. Any loose pieces of tape could travel through the system and obstruct the flow of oil or cause jamming of precision-fit parts.**
3. Connect the stressing hose from the stressing jack to the "A" port of the valve. See Figure 2.
4. Connect the return hose of the stressing jack to the "B" port of the valve. **NOTE: Always connect the return line to port "B".**
5. Attach the tool to the tensioning cable.
6. Shift the valve to port "A". The jack will tension the cable.
7. To hold cable tension, shift the valve to the center position.
8. Shift the valve to return port "B". The cable tension will be held while the wedge ram extends and builds pressure. The pilot-operated check valve will open when the correct pressure ratio has been reached, allowing the stressing jack to return.

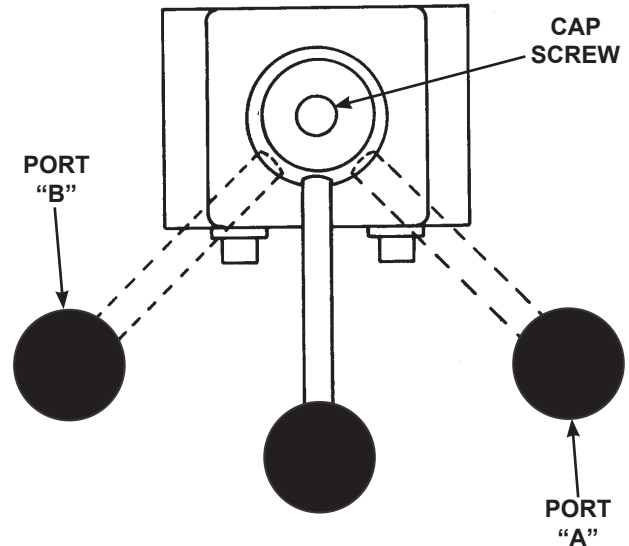



FIGURE 1

 **WARNING:** For use on PE30 Series pumps replace the mounting screws with longer mounting screws (No. 10856). See Figure 2.

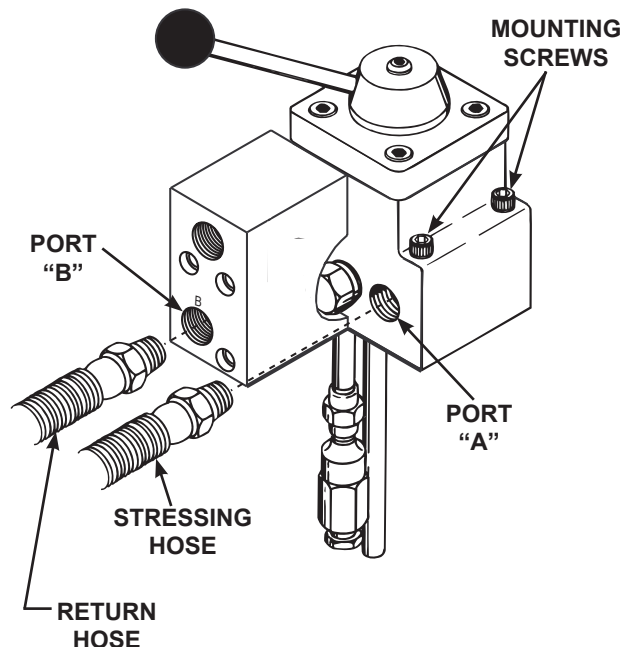

FIGURE 2